

PHILIPS

Data handbook



Electronic
components
and materials

Components and materials

Part 2 December 1982

Television tuners

Video modulators

Surface acoustic wave filters

COMPONENTS AND MATERIALS

PART 2 - DECEMBER 1982

TUNERS

TELEVISION TUNERS AND AERIAL INPUT ASSEMBLIES

VIDEO MODULATORS

SURFACE ACOUSTIC WAVE FILTERS

CONTENTS



DATA HANDBOOK SYSTEM

Our Data Handbook System is a comprehensive source of information on electronic components, sub-assemblies and materials; it is made up of four series of handbooks each comprising several parts.

ELECTRON TUBES	BLUE
SEMICONDUCTORS	RED
INTEGRATED CIRCUITS	PURPLE
COMPONENTS AND MATERIALS	GREEN

The several parts contain all pertinent data available at the time of publication, and each is revised and reissued periodically.

Where ratings or specifications differ from those published in the preceding edition they are pointed out by arrows. Where application information is given it is advisory and does not form part of the product specification.

If you need confirmation that the published data about any of our products are the latest available, please contact our representative. He is at your service and will be glad to answer your inquiries.

This information is furnished for guidance, and with no guarantee as to its accuracy or completeness; its publication conveys no licence under any patent or other right, nor does the publisher assume liability for any consequence of its use; specifications and availability of goods mentioned in it are subject to change without notice; it is not to be reproduced in any way, in whole or in part without the written consent of the publisher.

ELECTRON TUBES (BLUE SERIES)

The blue series of data handbooks is comprised of the following parts:

- T1 Tubes for r.f. heating**
- T2 Transmitting tubes for communications**
- T3 Klystrons, travelling-wave tubes, microwave diodes**
- ET3 Special Quality tubes, miscellaneous devices (will not be reprinted)**
- T4 Magnetrons**
- T5 Cathode-ray tubes**
Instrument tubes, monitor and display tubes, C.R. tubes for special applications
- T6 Geiger-Müller tubes**
- T7 Gas-filled tubes**
Segment indicator tubes, indicator tubes, dry reed contact units, thyratrons, industrial rectifying tubes, ignitrons, high-voltage rectifying tubes, associated accessories
- T8 Picture tubes and components**
Colour TV picture tubes, black and white TV picture tubes, colour monitor tubes for data graphic display, monochrome monitor tubes for data graphic display, components for colour television, components for black and white television and monochrome data graphic display
- T9 Photo and electron multipliers**
Photomultiplier tubes, phototubes, single channel electron multipliers, channel electron multiplier plates
- T10 Camera tubes and accessories, image intensifiers**
- T11* Microwave components and assemblies**

* Will become available in the course of 1982.

SEMICONDUCTORS (RED SERIES)

The red series of data handbooks is comprised of the following parts:

- S1 Diodes**
Small-signal germanium diodes, small-signal silicon diodes, voltage regulator diodes (< 1,5 W), voltage reference diodes, tuner diodes, rectifier diodes
- S2 Power diodes, thyristors, triacs**
Rectifier diodes, voltage regulator diodes (> 1,5 W), rectifier stacks, thyristors, triacs
- S3 Small-signal transistors**
- S4 Low-frequency power transistors and hybrid IC modules**
- S5 Field-effect transistors**
- S6 R.F. power transistors and modules**
- S7 Microminiature semiconductors for hybrid circuits**
- S8 Devices for optoelectronics**
Photosensitive diodes and transistors, light-emitting diodes, displays, photocouplers, infrared sensitive devices, photoconductive devices.
- S9 Taken into handbook T11 of the blue series**
- S10 Wideband transistors and wideband hybrid IC modules**

INTEGRATED CIRCUITS (PURPLE SERIES)

The purple series of data handbooks is comprised of the following parts:

- IC1** Bipolar ICs for radio and audio equipment
- IC2** Bipolar ICs for video equipment
- IC3** ICs for digital systems in radio, audio and video equipment
- IC4** Digital integrated circuits
LOC MOS HE4000B family
- IC5** Digital integrated circuits – ECL
ECL10 000 (GX family), ECL100 000 (HX family), dedicated designs
- IC6*** Professional analogue integrated circuits
- IC7** Signetics bipolar memories
- IC8** Signetics analogue circuits
- IC9** Signetics TTL logic

* This handbook will be available by the end of 1982.

COMPONENTS AND MATERIALS (GREEN SERIES)

The green series of data handbooks is comprised of the following parts:

- C1 Assemblies for industrial use**
PLC modules, PC20 modules, HN1L FZ/30 series, NORbits 60-, 61-, 90-series, input devices, hybrid ICs, peripheral devices
- C2 Television tuners, video modulators, surface acoustic wave filters**
- C3 Loudspeakers**
- C4 Ferroxcube potcores, square cores and cross cores**
- C5 Ferroxcube for power, audio/video and accelerators**
- C6 Electric motors and accessories**
Permanent magnet synchronous motors, stepping motors, direct current motors
- C7 Variable capacitors**
- C8 Variable mains transformers**
- C9 Piezoelectric quartz devices**
Quartz crystal units, temperature compensated crystal oscillators, compact integrated oscillators, quartz crystal cuts for temperature measurements
- C10 Connectors**
- C11 Non-linear resistors**
Voltage dependent resistors (VDR), light dependent resistors (LDR), negative temperature coefficient thermistors (NTC), positive temperature coefficient thermistors (PTC)
- C12 Variable resistors and test switches**
- C13 Fixed resistors**
- C14 Electrolytic and solid capacitors**
- C15 Film capacitors, ceramic capacitors**
- C16 Piezoelectric ceramics, permanent magnet materials**

TELEVISION TUNERS AND AERIAL INPUT ASSEMBLIES



V.H.F./U.H.F. TELEVISION TUNER

QUICK REFERENCE DATA

Systems	C.C.I.R. systems B and G
Channels	E2 to R4 (band I) ←
	M4 to E12 (band III)
	E21 to E69 (bands IV and V)
Intermediate frequencies	
picture	38,9 MHz
sound	33,4 MHz

APPLICATION

Designed to cover the v.h.f. and u.h.f. channels of C.C.I.R. systems B and G, with extended v.h.f. frequency ranges. This tuner is basically interchangeable with the ELC2000.



DESCRIPTION

→ The ELC2004 is a combined v.h.f./u.h.f. tuner with electronic tuning and band switching, covering the v.h.f. band I, E2 to the Italian channel C and the OIRT channel R4 (frequency range 48 to 92 MHz), the v.h.f. band III including the Morocco channel M4 (frequency range 162 to 230 MHz), and the u.h.f. band (frequency range 470 to 861 MHz).

Mechanically, the tuner is built on a low-loss printed-wiring board, carrying all components, in a metal housing made of a rectangular frame and front and rear cover (see Fig. 2). The two aerial connections (v.h.f. and u.h.f.) are on the two frame sides, all other connections (supply voltages, a.g.c. voltage, tuning and switching voltages) are made via feed-through capacitors in the underside. The mounting method is shown in Figs 3 and 4.

Electrically, the tuner consists of v.h.f. and u.h.f. parts. The v.h.f. aerial signal is fed via an i.f. trap, combined with a high-pass filter and switchable bandpass filters, to the emitter of the input transistor BF200. The collector load of this transistor is formed by a double tuned circuit, transferring the signal to the base of the mixer transistor BF199. The oscillator is equipped with a transistor BF494. The three r.f. circuits are tuned by three capacitance diodes BB809. Switching between v.h.f. I and III is → achieved by five switching diodes BA 482, 483 and 484.

The collector circuit of the mixer transistor is a single tuned i.f. resonant circuit, at the low end of which the i.f. signal is capacitively coupled out of the tuner. A test point at the collector of the mixer can be used for i.f. injection to align the i.f. output circuit of the tuner together with the i.f. amplifier of the television receiver.

The u.h.f. part of the tuner consists of a high-pass input circuit, connected to the emitter of the amplifier transistor BF180. The interstage network between this transistor and the self-oscillating mixer stage is formed by a double tuned circuit. A transistor BF181 acts as a self-oscillating mixer.

→ The three tuned u.h.f. circuits are tuned by three capacitance diodes BB405B. The output of the self-oscillating mixer is fed to a double tuned i.f. circuit which is connected to the base of the v.h.f. mixer transistor BF199, now operating as an i.f. amplifier.

The tuner requires transistor supply voltages of + 11 V, a switching voltage of + 11 V, a.g.c. voltages, variable from + 2,4 V (normal operating point) to about + 9 V (maximum a.g.c.) and a tuning voltage, variable from + 0,5 V to + 28 V.

The aerial inputs of the tuner are asymmetrical. For use in symmetrical aerial systems, aerial transformers (baluns) are available (see Accessories).

The ELC2004 tuner is basically interchangeable with the ELC2000. Small modifications in the receiver with respect to a.g.c. and supply voltages may be necessary.

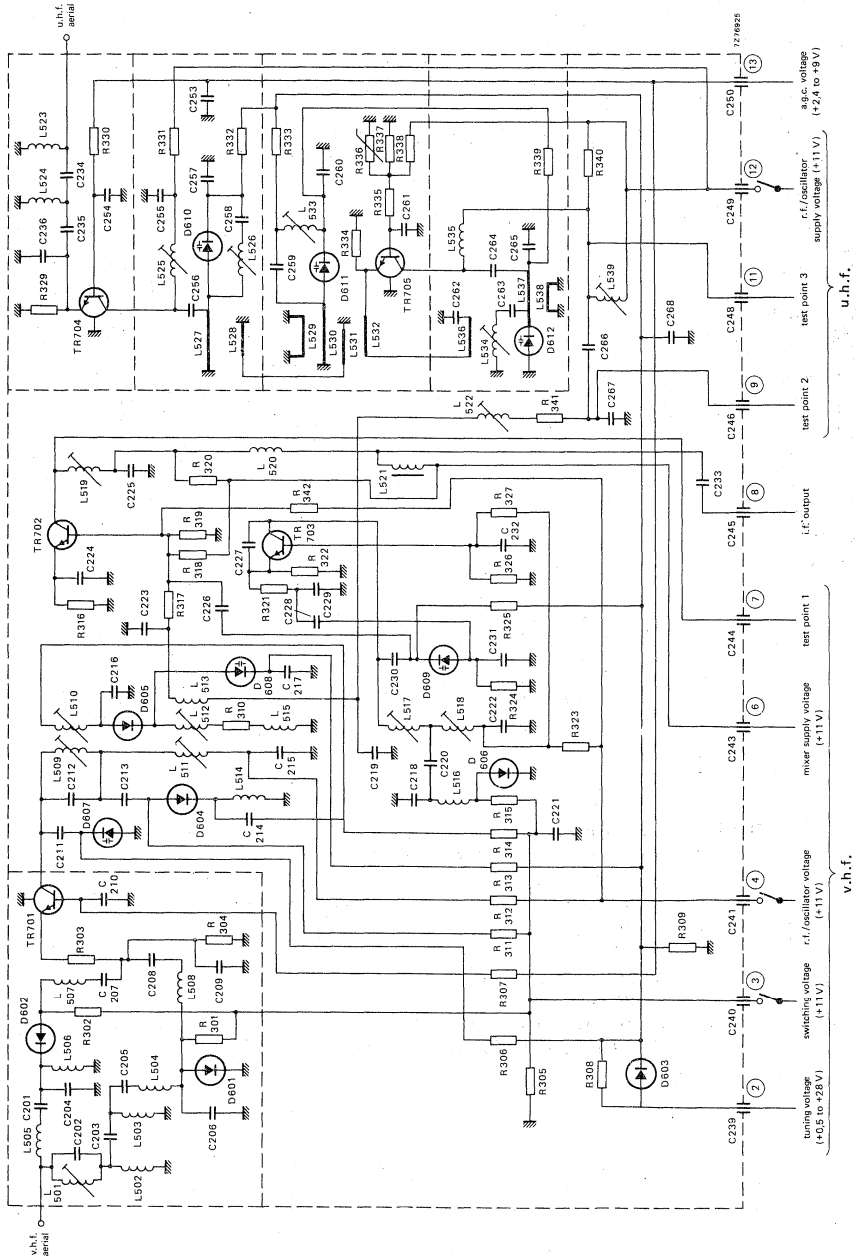
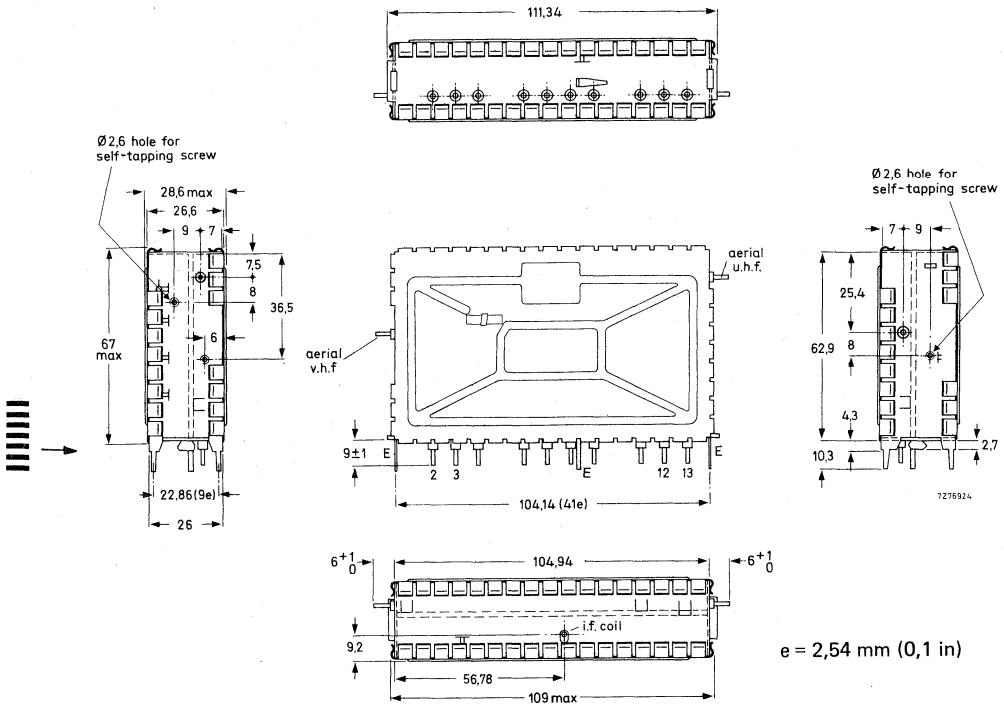

Fig. 1.

MECHANICAL DATA

Dimensions in mm



e = 2,54 mm (0,1 in)

Fig. 2.

- Terminal 2 = tuning voltage, + 0,5 to + 28 V
- 3 = switching voltage, + 11 V (approx. 20 mA)
- 4 = r.f./oscillator supply voltage, v.h.f., + 11 V (approx. 6 to 13 mA)
- 6 = mixer supply voltage, v.h.f., + 11 V (approx. 5 mA)
- 7 = test point 1, v.h.f.
- 8 = i.f. output
- 9 = test point 2 (alignment short)
- 11 = test point 3, u.h.f.
- 12 = r.f./oscillator supply voltage, u.h.f., + 11 V (approx. 6 to 13 mA)
- 13 = a.g.c. voltage, + 2,4 to + 9 V (3,5 mA)
- E = earth

Mounting

The tuner may be mounted by soldering it on to a printed-wiring board, using the piercing diagram shown in Fig. 3. (The tuner may also be mounted by means of a bracket. Information will be supplied upon request.) The tuner may be mounted anywhere in the receiver and there are no restrictions on orientation.

The solderability of the terminals and mounting tabs is according to IEC 68-2, test Ta ($230 \pm 10 \text{ }^\circ\text{C}$, $2 \pm 0,5 \text{ s}$). The resistance to soldering heat is according to IEC 68-2, test Tb ($260 \pm 5 \text{ }^\circ\text{C}$, $10 \pm 1 \text{ s}$).

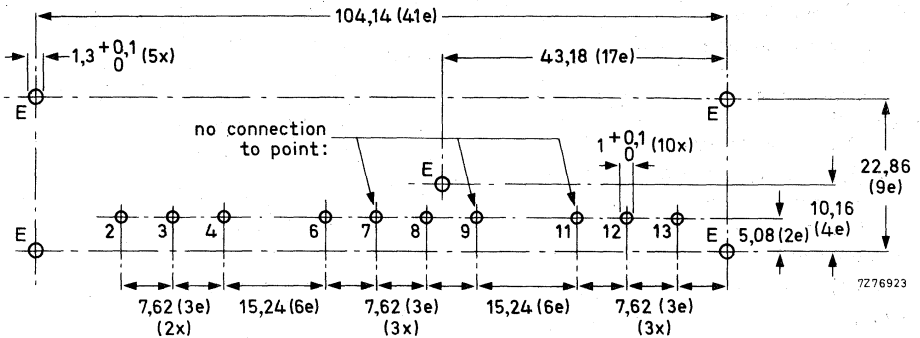

Fig. 3 Piercing diagram viewed from solder side of board; e = 2,54 mm (0,1 in). No connection must be made to the points 7, 9 and 11, as otherwise the oscillator radiation would increase.

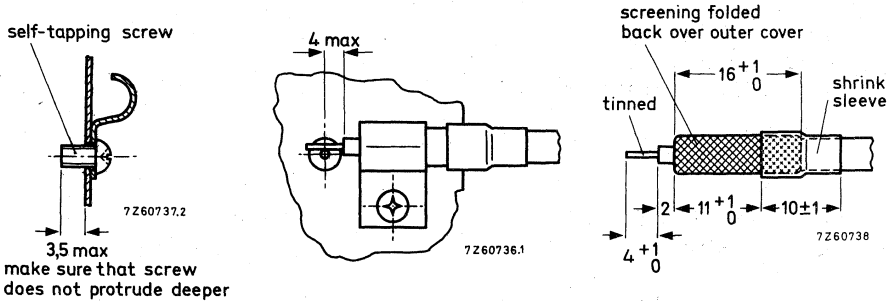

Fig. 4 Recommended fixing method of the aerial cables. Use a self-tapping screw.

ELECTRICAL DATA

Unless otherwise specified all electrical values apply at an ambient temperature of 25 ± 5 °C, a relative humidity of $60 \pm 15\%$, a supply voltage of $11 \pm 0,3$ V and an a.g.c. voltage of $2,4 \pm 0,2$ V.

Semiconductors, bands I and III

r.f. amplifier	BF200
mixer	BF199
oscillator	BF494
→ tuning diodes	3 x BB809
→ switching diodes	5 x BA482/483/484

Semiconductors, bands IV and V

r.f. amplifier	BF180
mixer/oscillator	BF181
→ tuning diodes	3 x BB405B
drift compensating diode	BAW62

Ambient temperature range

operating	+ 5 to + 55 °C
storage	-25 to + 85 °C

Relative humidity

max. 90%

Supply voltage

+ 11 V \pm 10%

Current drawn from + 11 V supply

band I	11 to 18 mA	} depending on a.g.c. voltage
band III	31 to 38 mA	
bands IV and V	11 to 18 mA	

A.G.C. voltage (Figs 5, 6 and 7)

band I, at nominal gain	+ 2,4 V
band I, at 40 dB gain reduction	+ 6,0 V (typical)
band III, at nominal gain	+ 2,4 V
band III, at 40 dB gain reduction	+ 5,0 V (typical)
bands IV and V, at nominal gain	+ 2,4 V
bands IV and V, at 40 dB gain reduction	+ 5,5 V (typical)

Note: A.G.C. voltages between 0 and + 10 V may be applied without risk of damage.

A.G.C. current	max. 3,5 mA
Tuning voltage range (Figs 8, 9 and 10)	+ 0,5 to + 28 V
Current drawn from 28 V tuning voltage supply	max. 35 μ A

Note: The source impedance of the tuning voltage offered to terminal 2 must be maximum 30 k Ω at tuning voltages below 2 V.

Switching voltage

band I	open circuit
band III	+ 11 V \pm 10%
bands IV and V	open circuit

Note: In the band I position, the tuner produces a negative voltage (1 to 5 V) at terminal 3; this terminal must not be loaded with an external resistance below 10 M Ω .

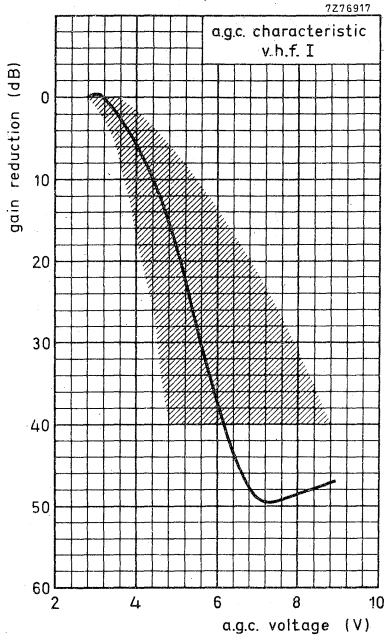

Fig. 5.

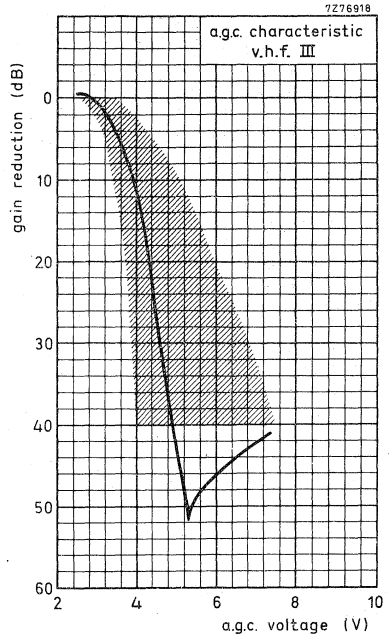

Fig. 6.

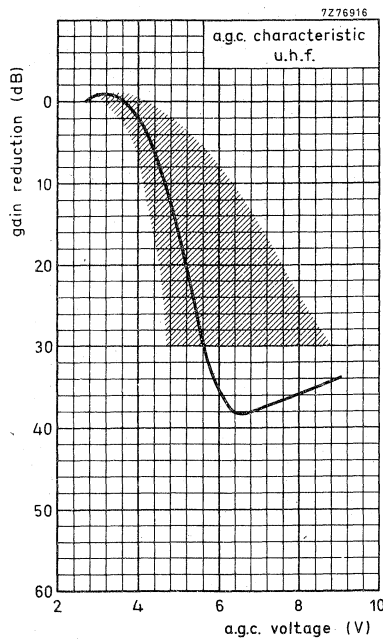

Fig. 7.

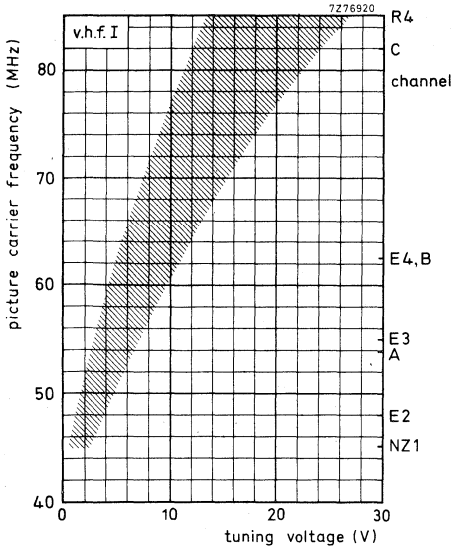

Fig. 8.

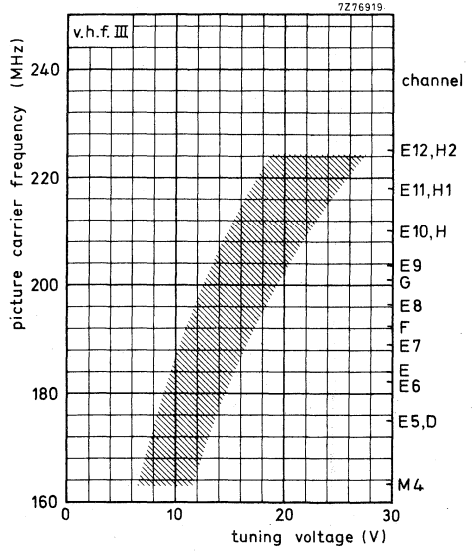

Fig. 9.

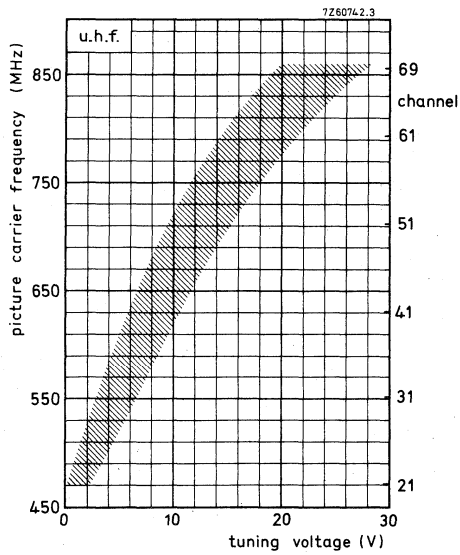

Fig. 10.

Frequency ranges
band I

— Channel E2 (picture carrier 48,25 MHz) to channel R4 (picture carrier 85,25 MHz).
Margin at the extreme channels: min. 1,2 MHz.

band III

— Channel M4 (picture carrier 163,25 MHz) to channel E12 (picture carrier 224,25 MHz).
Margin at the extreme channels: min. 2 MHz.

bands IV and V

— Channel E21 (picture carrier 471,25 MHz) to channel E69 (picture carrier 855,25 MHz).
Margin at the extreme channels: min. 3 MHz.

Intermediate frequencies

picture

38,9 MHz

sound

33,4 MHz

Input impedance

asymmetrical

75 Ω

symmetrical

300 Ω (see Accessories)

V.S.W.R. (between picture carrier and sound carrier)

v.s.w.r. at nom. gain

max. v.s.w.r. during gain control

band I

max. 4

max. 5

band III

max. 4

max. 5

bands IV and V

max. 5

max. 5

A.G.C. range

band I

min. 40 dB

band III

min. 40 dB

bands IV and V

min. 30 dB

R.F. curves, bandwidth

band I

typ. 10 to 15 MHz

band III

typ. 10 to 17 MHz

bands IV and V

typ. 15 to 25 MHz

R.F. curves, tilt

band I

max. 3 dB

band III

max. 3 dB

bands IV and V, channels E21 to E60

max. 3 dB

bands IV and V, channels E61 to E69

max. 4 dB

Power gain (see also Measuring method of power gain)

band I

min. 25 dB

band I, channel E2

typ. 28 dB

band I, channel C

typ. 30 dB

band III, except channel M4

min. 25 dB

band III, channel M4

min. 24 dB

band III, channel E5

typ. 27 dB

band III, channel E11

typ. 29 dB

bands IV and V

min. 25 dB

bands IV and V, channel E21

typ. 30 dB

bands IV and V, channel E31

typ. 28 dB

bands IV and V, channel E69

typ. 32 dB

Noise figure

band I	max. 8 dB
band I, channel E4	typ. 5,5 dB
band III, except channel M4	max. 8 dB
band III, channel M4	max. 10 dB
band III, channel E9	typ. 6 dB
bands IV and V	max. 11 dB
bands IV and V, channel E21	typ. 7 dB
bands IV and V, channel E51	typ. 8,5 dB
bands IV and V, channel E69	typ. 9 dB

I.F. rejection

band I, channel E2	min. 40 dB
band I, channel C	min. 60 dB
band III	min. 60 dB
bands IV and V	min. 60 dB

Image rejection

band I	min. 40 dB
band III	min. 60 dB
bands IV and V	min. 40 dB

Signal handling (see also Figs 12 and 13)

Minimum input signal (e.m.f.) producing cross-modulation (1%) at nominal gain in channel (wanted signal: picture carrier frequency; interfering signal: sound carrier frequency)

v.h.f. I	typ. 4 mV	} notes 1 and 2
v.h.f. III	typ. 4 mV	
u.h.f.	typ. 5 to 10 mV	

Minimum input signal (e.m.f.) producing cross-modulation (1%) at nominal gain in band (wanted signal: picture carrier frequency of channel X; interfering signal: picture carrier of v.h.f. channel X-2, u.h.f. channel X-5)

v.h.f. I	typ. 20 to 40 mV	} notes 1 and 2
v.h.f. III	typ. 10 to 20 mV	
u.h.f.	typ. 10 to 20 mV	

Minimum input signal (e.m.f.) producing overloading

at nominal gain	typ. 30 mV	} notes 1 and 3
at maximum a.g.c.	typ. > 200 mV	

Minimum input signal (e.m.f.) at nominal gain producing a shift of oscillator frequency of 10 kHz

band I	typ. > 25 mV	} note 1
band III	typ. > 25 mV	
band IV and V	typ. 6 to 10 mV	

Detuning of the i.f. output circuit as a result of band switching and tuning with respect to channel E8

max. 400 kHz

Shift of oscillator frequency at a change of supply voltage of 10%

band I	max. 300 kHz
band III	max. 300 kHz
band IV and V	max. 600 kHz

Shift of oscillator frequency at a gain reduction of 30 dB

max. 100 kHz

Notes see next page.

Drift of oscillator frequency during warm-up time

(measured between 5 s and 15 min after switching on)

band I	max. 100 kHz
band III	max. 100 kHz
bands IV and V	max. 250 kHz

Drift of oscillator frequency at a change of ambient temperature from 25 to 40 °C

band I	max. 300 kHz
band III	max. 300 kHz
bands IV and V	max. 500 kHz

Oscillator radiation

The tuner is in conformity with the radiation requirements of C.I.S.P.R. publication No. 13, provided the following conditions are fulfilled.

- A low-pass filter (Fig. 11) with a cut-off frequency of about 300 MHz has to be inserted between the v.h.f. aerial terminal of the tuner and the aerial terminal of the receiver.
Television receivers with a common v.h.f./u.h.f. connector in combination with a low-pass/high-pass splitter do not need this additional filter.

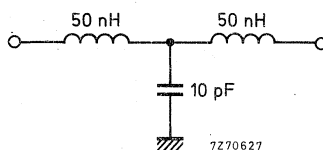

Fig. 11.

- No connections must be made to terminals 7, 9 and 11.
- Earthing of the tuner and connections to the i.f. amplifier has to be done in such a way, that additional radiation is prevented.

Microphonics

If the tuner is installed in a professional manner, there will be no microphonics.

Surge protection

Protection against voltages

max. 8 kV

Note: Three discharges of a 470 pF capacitor into the aerial terminal.

Protection against flashes

max. 30 kV, 400 mWs

Note: A flash-over circuit producing flashes with frequencies of 1 to 20 Hz for 30 s is connected to the aerial terminal.

Notes

1. Referred to an impedance of 75 Ω .
2. 1% cross-modulation means that 1% of the modulation depth of the interfering signal is transferred to the wanted signal.
3. Criterion of overloading: 30% compression of the synchronization pulses of a standard television signal or a noticeable deterioration of the picture quality.

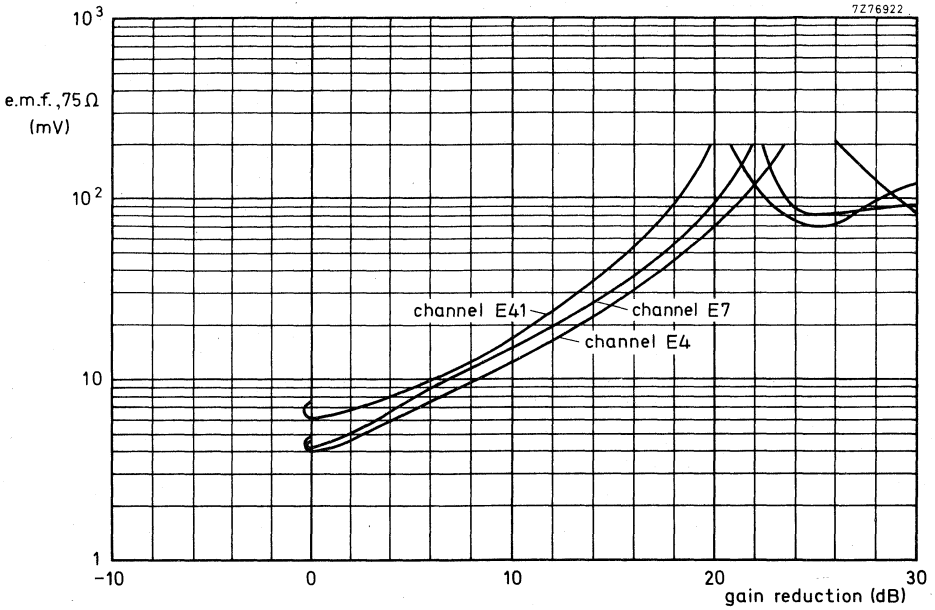

Fig. 12 Cross-modulation, in channel.

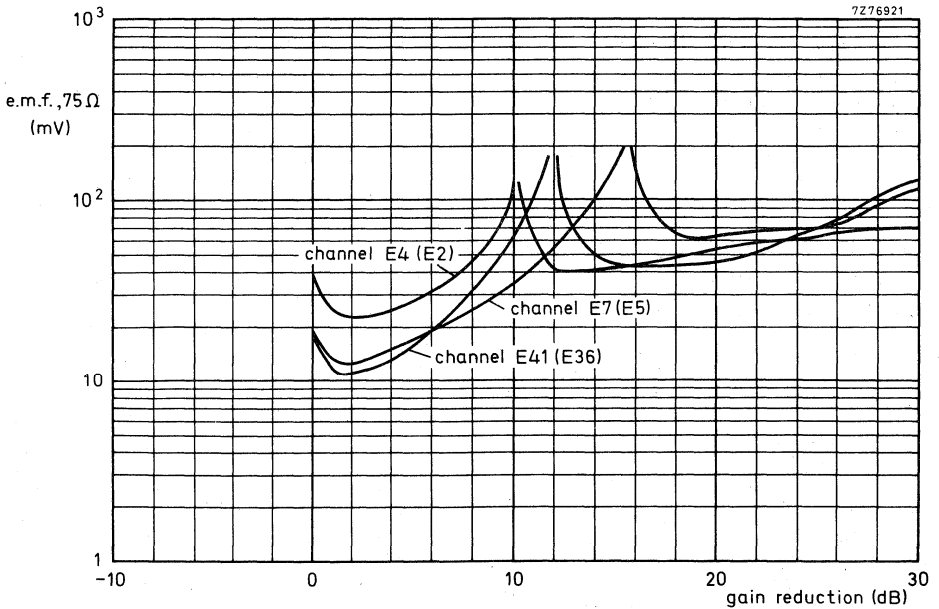

Fig. 13 Cross-modulation, in band; the interfering channels are given between brackets.

APPLICATION INFORMATION

Connection of the tuner

For connection of the tuner the terminal location, Fig. 2, should be consulted. If the tuner is used in receivers the chassis of which is connected to the mains, isolating capacitors according to the safety rules have to be inserted in the aerial leads. A convenient way of connecting is given below.

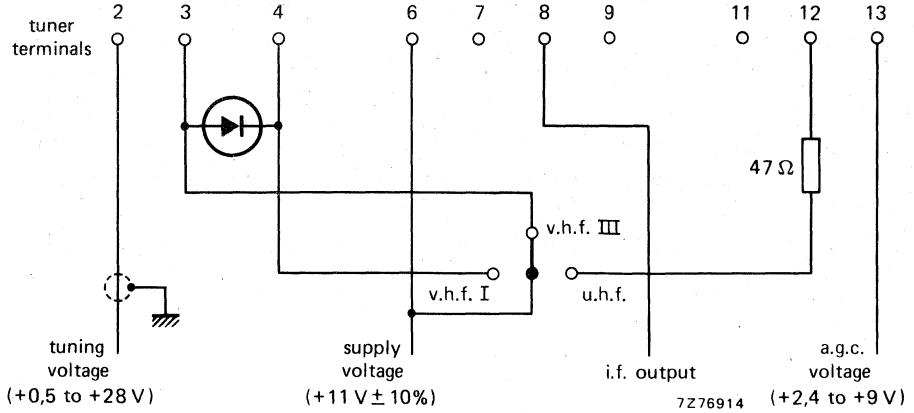
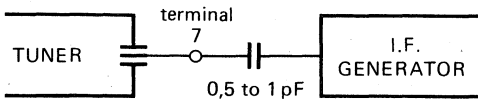

Fig. 14 Connection diagram; diode: BAX13, BA217 or comparable silicon diode.

Alignment of the i.f. circuit

The tuner is provided with a test point at the collector of the v.h.f. mixer, which can be used for i.f. injection to align the i.f. output circuit. The i.f. signal should be fed to test point 1 (terminal 7) via a capacitor of 0,5 to 1 pF (Fig. 15). This capacitor should have short leads to avoid oscillator radiation. After alignment it should be soldered to earth, to avoid detuning of the i.f. circuit (Fig. 16).



7Z76915.1

Fig. 15.

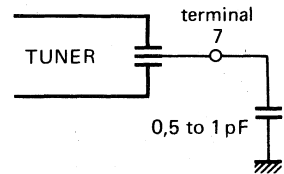

Fig. 16.

In receivers where the tuner is soldered into a printed-wiring board, the capacitor can be printed as shown in Figs 17 and 18.

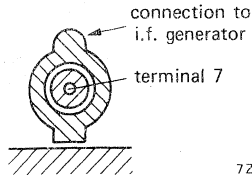

Fig. 17.

7Z76913

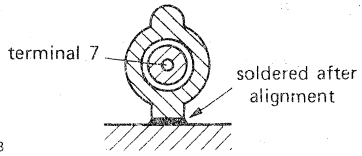

Fig. 18.

The aligning should be done with the v.h.f. III band tuned. The tuning voltage should be 15 to 20 V. If this injection method cannot be employed in the television receiver (e.g. there is not enough i.f. signal available) the i.f. signal can be fed to test point 3 (terminal 11) via a capacitor of 0,82 to 1 pF. The tuner must be switched to the u.h.f. position; the tuning voltage should be approx. 10 V. This injection method requires approx. 14 dB less signal than the first method. The capacitor has to be removed after alignment. No permanent connection must be made to test point 3, otherwise the tuner may exceed the oscillator radiation limits.

MEASURING METHOD OF POWER GAIN

The i.f. output of the tuner should be terminated with the circuit given in Fig. 19. The terminals 7, 9 and 11 should be not connected.

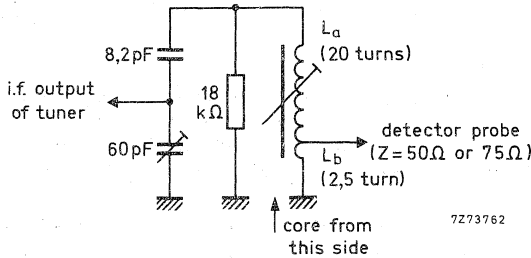

Fig. 19.

7Z73762

Switch the tuner to the v.h.f. III band; the tuning voltage should be 15 to 20 V. Feed an i.f. sweep signal (e.m.f. 500 to 1000 mV) to test point 1 as given in Alignment of the i.f. circuit. Adjust the trimmer (Fig. 19), tunable coil (L_a/L_b), i.f. output coil of the tuner L519 (Fig. 1) and the coupling between L_a and L_b to get the resonant curve as given in Fig. 20.

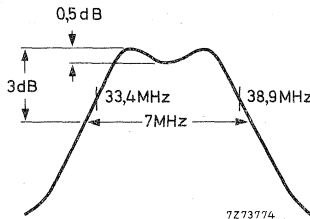

Fig. 20.

7Z73774

Then display the r.f. + i.f. curve of the tuner at 190 MHz (picture carrier frequency) and make small corrections in the alignment of the i.f. coils (L_a/L_b and L519), if necessary, to get the 38,9 MHz and 33,4 MHz markers symmetrically on the slopes of the curve and the peaks at equal amplitude.

Because the output impedance of the dummy circuit is 50 to 75 Ω , the power gain can be measured in the conventional manner by inserting tuner and dummy circuit between a 75 Ω source and a 75 Ω detector (or between a 50 Ω source and matching pad 50/75 Ω and a 50 Ω detector).

ACCESSORIES

Aerial input transformer ELC1094, v.h.f., catalogue number: 2422 542 10941.

Aerial input transformer ELC2092, u.h.f., catalogue number: 2422 542 12921.

Coaxial aerial input assembly, with safety capacitors, catalogue number: 3122 127 10450.

Coaxial aerial input assembly, without safety capacitors, catalogue number: 3122 128 57720.



V.H.F./U.H.F. TELEVISION TUNER**QUICK REFERENCE DATA**

Systems	C.C.I.R. systems B and G
Channels	
low v.h.f. band	E2 to R4
high v.h.f. band	S2 to S19
u.h.f. band	E21 to E69
Intermediate frequencies	
picture	38,9 MHz
sound	33,4 MHz

APPLICATION

This tuner is designed to cover the v.h.f. and u.h.f. channels of C.C.I.R. systems B and G, including the S channels for cable television. It is interchangeable with tuner ELC2004.



DESCRIPTION

The ELC2006 is a combined v.h.f./u.h.f. tuner with electronic tuning and band switching, covering the low v.h.f. band with the channels E2 to R4 (frequency range 47 to 92 MHz), the high v.h.f. band with the channels S2 to S19 (frequency range 111 to 293 MHz), and the u.h.f. band with the channels E21 to E69 (frequency range 470 to 861 MHz).

Mechanically, the tuner is built on a low-loss printed-wiring board, carrying all components, in a metal housing made of a rectangular frame and front and rear covers (see Fig. 2). The two aerial connections (v.h.f. and u.h.f.) are on the two frame sides, all other connections (supply voltages, a.g.c. voltage, tuning and switching voltages) are made via feed-through capacitors in the under side. The mounting method is shown in Figs 3 and 4.

Electrically, the tuner consists of v.h.f. and u.h.f. parts. The v.h.f. aerial signal is fed via an i.f. trap, combined with a high-pass filter, to a tuned input circuit, which is connected to the emitter of the input transistor BF200. The collector load of this transistor is formed by a double tuned circuit, transferring the signal to the base of the mixer transistor BF183. The oscillator is equipped with a transistor BF494. The four r.f. circuits are tuned by four capacitance diodes BB909B. A capacitance diode BB809 provides a frequency-dependent coupling of the r.f. input signal to the tuned input circuit. Switching between the low and high v.h.f. bands is done by four switching diodes (BA482/483/484). Three switching diodes BA317 are used to make the tuner interchangeable with the ELC2004.

The collector circuit of the mixer transistor is a single tuned i.f. resonant circuit, at the low end of which the i.f. signal is capacitively coupled out of the tuner (low capacitance coupling). An i.f. injection point is provided at the collector of the mixer, for aligning this circuit together with the i.f. amplifier of the television receiver.

The u.h.f. part of the tuner consists of a high-pass input circuit, connected to the emitter of the amplifier transistor BF180. The inter-stage network between this transistor and the self-oscillating mixer stage is formed by a double tuned circuit. A transistor BF181 acts as a self-oscillating mixer.

The three tuned u.h.f. circuits are tuned by three capacitance diodes BB405B.

The output of the self-oscillating mixer is fed to a double tuned i.f. circuit which is connected to the emitter of the v.h.f. mixer transistor BF183, now operating as an i.f. amplifier in grounded-base configuration. Band switching between v.h.f. and u.h.f. is achieved by a diode BA243.

The tuner requires transistor supply voltages of + 11 V, a switching voltage of + 11 V, a.g.c. voltages, variable from + 2,4 V (normal operating point) to about + 9 V (maximum a.g.c.) and a tuning voltage, variable from + 0,5 V to + 28 V.

The aerial inputs of the tuner are asymmetrical. For use in symmetrical aerial systems, aerial transformers (baluns) are available (see ACCESSORIES).

MECHANICAL DATA

Dimensions in mm

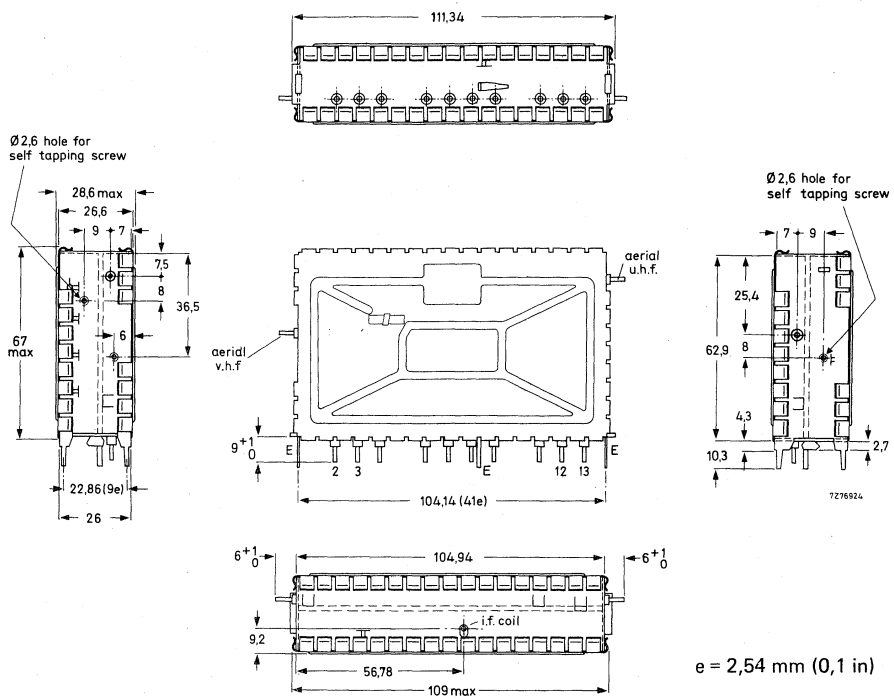

e = 2,54 mm (0,1 in)

Fig. 2.

- Terminal 2 = tuning voltage, + 0,5 to + 28 V
- 3 = switching voltage, + 11 V (approx. 12 mA)
- 4 = supply voltage, v.h.f., + 11 V (approx. 9 to 16 mA)
- 6 = mixer supply voltage, v.h.f., + 11 V (approx. 5 mA)
- 7 = test point 1, v.h.f.
- 8 = i.f. output
- 9 = test point 2 (alignment short)
- 11 = test point 3, u.h.f.
- 12 = supply voltage, u.h.f., + 11 V (approx. 17 to 24 mA)
- 13 = a.g.c. voltage, + 2,4 to + 9 V (max. 3.5 mA)
- E = earth

Mounting

The tuner may be mounted by soldering it on to a printed-wiring board, using the piercing diagram shown in Fig. 3. (The tuner may also be mounted by means of a bracket. Information will be supplied upon request.) The tuner may be mounted anywhere in the receiver and there are no restrictions on orientation.

The solderability of the terminals and mounting tabs is according to IEC 68-2, test Ta ($230 \pm 10 \text{ }^\circ\text{C}$, $2 \pm 0,5 \text{ s}$). The resistance to soldering heat is according to IEC 68-2, test Tb ($260 \pm 5 \text{ }^\circ\text{C}$, $10 \pm 1 \text{ s}$).

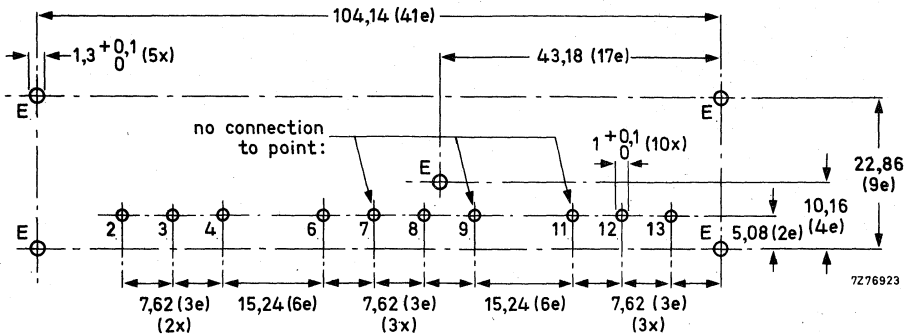

Fig. 3 Piercing diagram viewed from solder side of board; $e = 2,54 \text{ mm}$ (0,1 in). No connection must be made to the points 7, 9 and 11, as otherwise the oscillator radiation would increase.

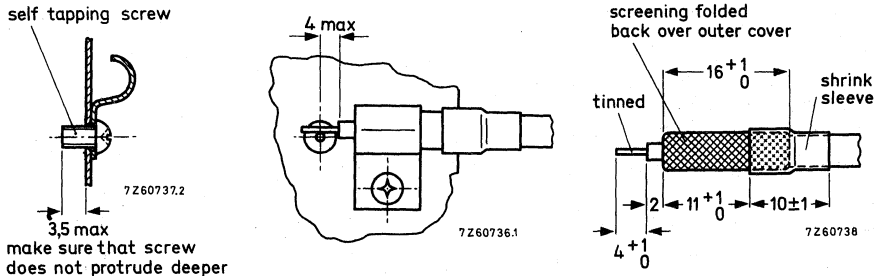

Fig. 4 Recommended fixing method of the aerial cables. Use a self-tapping screw, e.g. 5N x 3/16.

ELECTRICAL DATA

Unless otherwise specified all electrical values apply at an ambient temperature of 25 ± 5 °C, a relative humidity of $60 \pm 15\%$, a supply voltage of $11 \pm 0,3$ V and an a.g.c. voltage of $2,4 \pm 0,2$ V.

General**Semiconductors**

v.h.f. bands: r.f. amplifier	BF200
mixer	BF183
oscillator	BF494
tuning diodes	4 x BB909B
coupling diode	BB809
switching diodes	5 x BA482/483/484, 3 x BA317
u.h.f. band: r.f. amplifier	BF180
mixer/oscillator	BF181
tuning diodes	3 x BB405B
drift compensating diode	BAW62

Ambient temperature range

operating	+ 5 to + 55 °C
storage	-25 to + 85 °C

Relative humidity (during operation)

max. 90%

Voltages and currents

Supply voltage	+ 11 V \pm 10%	
Current drawn from + 11 V supply		
low v.h.f. band	9 to 16 mA	} depending on a.g.c. voltage
high v.h.f. band	21 to 28 mA	
u.h.f. band	17 to 24 mA	
A.G.C. voltage (Figs 5, 6 and 7)		
low v.h.f. band, at nominal gain	+ 2,4 V	
at 40 dB gain reduction	typ. + 5,5 V	
high v.h.f. band, at nominal gain	+ 2,4 V	
at 40 dB gain reduction	typ. + 4,5 V	
u.h.f. band, at nominal gain	+ 2,4 V	
at 30 dB gain reduction	typ. + 5,0 V	

Note: A.G.C. voltages between 0 and + 10 V may be applied without risk of damage.

A.G.C. current	max. 3,5 mA
Tuning voltage range (Figs 8, 9 and 10)	+ 0,5 to + 28 V
Current drawn from 28 V tuning voltage supply	max. 35 μ A

Note: The source impedance of the tuning voltage offered to terminal 2, must be max. 30 k Ω at tuning voltages below 2 V.

Switching voltage

low v.h.f. band	open circuit
high v.h.f. band	+ 11 V \pm 10%
u.h.f. band	open circuit

Note: In the low v.h.f. band position, the tuner produces a negative voltage (1 to 5 V) at terminal 3; this terminal must not be loaded with an external resistance below 10 M Ω .

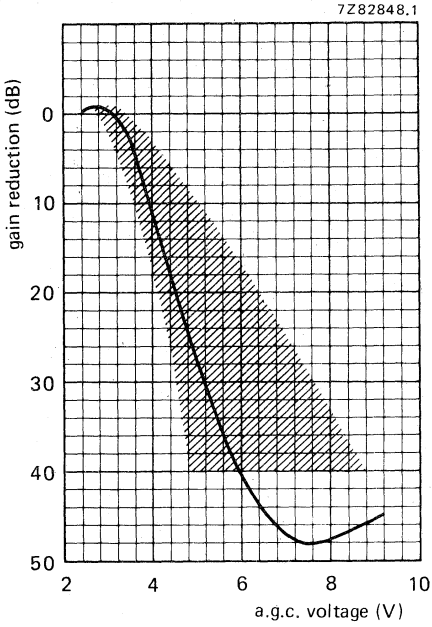

Fig. 5 Low v.h.f. band.

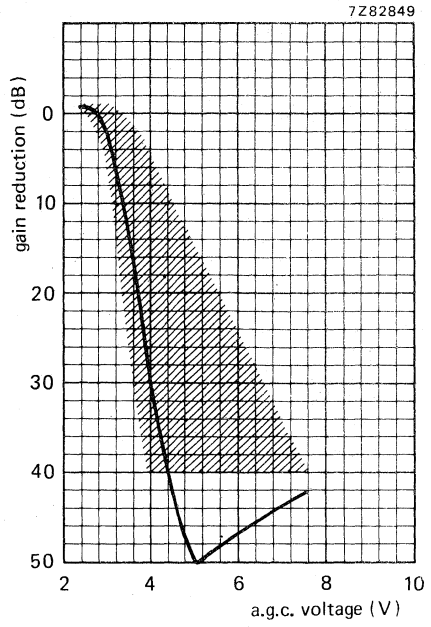

Fig. 6 High v.h.f. band.

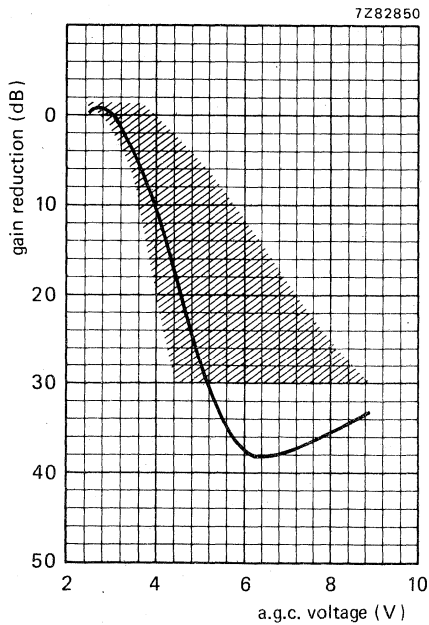

Fig. 7 U.H.F. band.

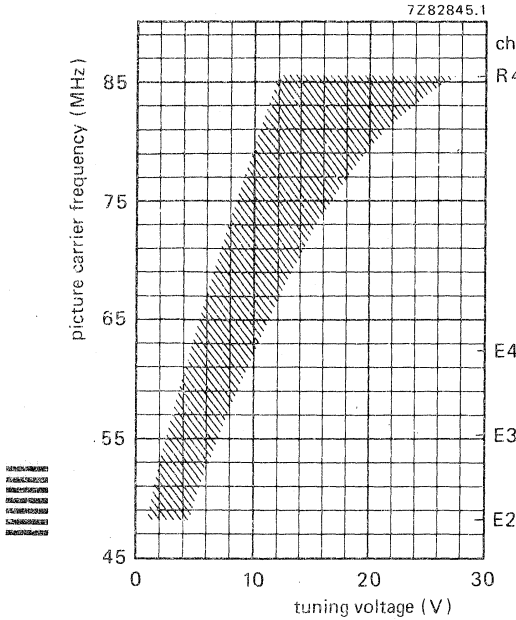

Fig. 8 Low v.h.f. band.

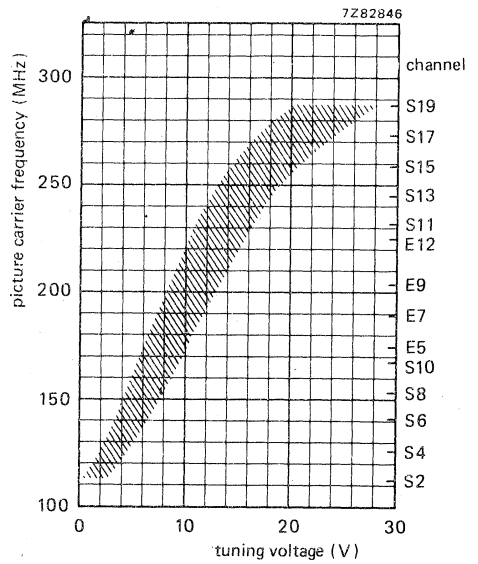

Fig. 9 High v.h.f. band.

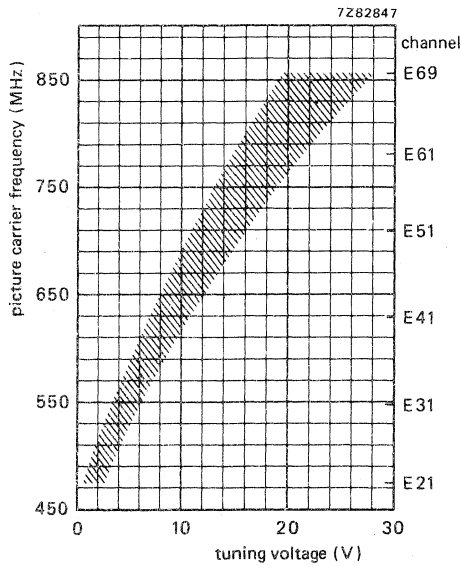

Fig. 10 U.H.F. band.

Frequencies

Frequency ranges

low v.h.f. band

high v.h.f. band

u.h.f. band

channel E2 (picture carrier 48,25 MHz) to channel R4 (picture carrier 85,25 MHz). Margin at the extreme channels: min. 1,2 MHz. channel S2 (picture carrier 112,25 MHz) to channel S19 (picture carrier 287,25 MHz). Margin at the extreme channels: min. 2 MHz. channel E21 (picture carrier 471,25 MHz) to channel E69 (picture carrier 855,25 MHz). Margin at the extreme channels: min. 3 MHz.

Intermediate frequencies

picture

sound

38,9 MHz

33,4 MHz

The oscillator frequency is higher than the input-signal frequency.

Wanted signal characteristics

Input impedance

asymmetrical

symmetrical

75 Ω

300 Ω (see ACCESSORIES)

V.S.W.R. (measured at picture carrier frequency of 38,9 MHz)

low v.h.f. band

high v.h.f. band

u.h.f. band

at nom. gain

during gain control

max. 5

max. 5

max. 5

max. 5,5

max. 5,5

max. 5

A.G.C. range

low v.h.f. band

high v.h.f. band

u.h.f. band

min. 40 dB

min. 40 dB

min. 30 dB

R.F. curves, bandwidth

low v.h.f. band

high v.h.f. band

u.h.f. band

typ. 10 MHz

typ. 12 MHz

typ. 16 MHz

R.F. curves, tilt

low v.h.f. band

high v.h.f. band

u.h.f. band, channels E21 to E60
channels E61 to E69

max. 3,5 dB

max. 4 dB

max. 3 dB

max. 4 dB



Power gain (see also MEASURING METHODS)

low v.h.f. band		min. 20 dB
	channel E2	typ. 25 dB
	channel R4	typ. 28 dB
high v.h.f. band,	channels S2 to S3	min. 17 dB
	channels S4 to S6	min. 19 dB
	channels S7 to S10	min. 20 dB
	channel S8	typ. 22 dB
	channels E5 to E12	min. 20 dB
	channel E8	typ. 24 dB
	channels S11 to S19	min. 20 dB
	channel S16	typ. 24 dB
u.h.f. band		min. 20 dB
	channel E21	typ. 26 dB
	channel E31	typ. 23 dB
	channel E69	typ. 28 dB

Gain difference

between any two v.h.f. channels, except channels S2 to S5		typ. 7 dB
between any two u.h.f. channels		typ. 5 dB
between any v.h.f. and u.h.f. channel, except channels S2 to S5		typ. 7 dB

Noise figure

low v.h.f. band		max. 9 dB
	channel E4	typ. 7,5 dB
high v.h.f. band,	channels S2 to S3	max. 12 dB
	channel S4	max. 11 dB
	channel S5	max. 10 dB
	channels S6 to S10	max. 9 dB
	channel S8	typ. 6,5 dB
	channels E5 to E12	max. 9 dB
	channel E8	typ. 6 dB
	channels S11 to S19	max. 9 dB
	channel S16	typ. 6,5 dB
u.h.f. band,	channels E21 to E60	max. 11 dB
	channels E61 to E69	max. 12 dB
	channel E21	typ. 7 dB
	channel E51	typ. 9 dB
	channel E69	typ. 9,5 dB

Unwanted signal characteristics**I.F. rejection**

low v.h.f. band, channel E2	min. 40 dB
channel E3	min. 50 dB
channels E4 to R4	min. 60 dB
high v.h.f. band, channels S2 to S10	min. 60 dB
channels E5 to E12	min. 60 dB
channels S11 to S19	min. 60 dB
u.h.f. band	min. 60 dB

Image rejection, at picture carrier frequency

low v.h.f. band	min. 57 dB
high v.h.f. band, channels S2 to S10	min. 60 dB
channels E5 to E12	min. 60 dB
channels S11 to S19	min. 53 dB
u.h.f. band	min. 40 dB

Signal handling (see also Figs 11 and 12)

Minimum input signal (e.m.f.) producing cross-modulation (1%) at nominal gain, in channel

(wanted signal: picture carrier frequency, interfering signal: sound carrier frequency),

low v.h.f. band	typ. 4 mV	} note 1
high v.h.f. band	typ. 4 mV	
u.h.f. band	typ. 5 to 10 mV	

in band

(wanted signal: picture carrier frequency of channel N,

interfering signal: picture carrier of channel N-2

(low v.h.f.), N-3 (high v.h.f.), N-5 (u.h.f.))

low v.h.f. band	typ. 20 to 40 mV	} note 1
high v.h.f. band	typ. 10 to 20 mV	
u.h.f. band	typ. 10 to 20 mV	

Minimum input signal (e.m.f.) producing overloading

at nominal gain

at maximum a.g.c.

typ. 30 mV	} note 2
typ. > 200 mV	

Minimum input signal (e.m.f.) at nominal gain producing a shift of the oscillator frequency of 10 kHz,

low v.h.f. band	typ. > 25 mV	} note 3
high v.h.f. band	typ. > 25 mV	
u.h.f. band	typ. 6 to 10 mV	

Notes

- This e.m.f. (open voltage) is referred to an impedance of 75 Ω .
1% cross-modulation means that 1% of the modulation depth of the interfering signal is transferred to the wanted signal.
- This e.m.f. (open voltage) is referred to an impedance of 75 Ω .
Criterion of overloading: 30% compression of the synchronization pulses of a standard television signal or a noticeable deterioration of the picture quality.
- This e.m.f. (open voltage) is referred to an impedance of 75 Ω .

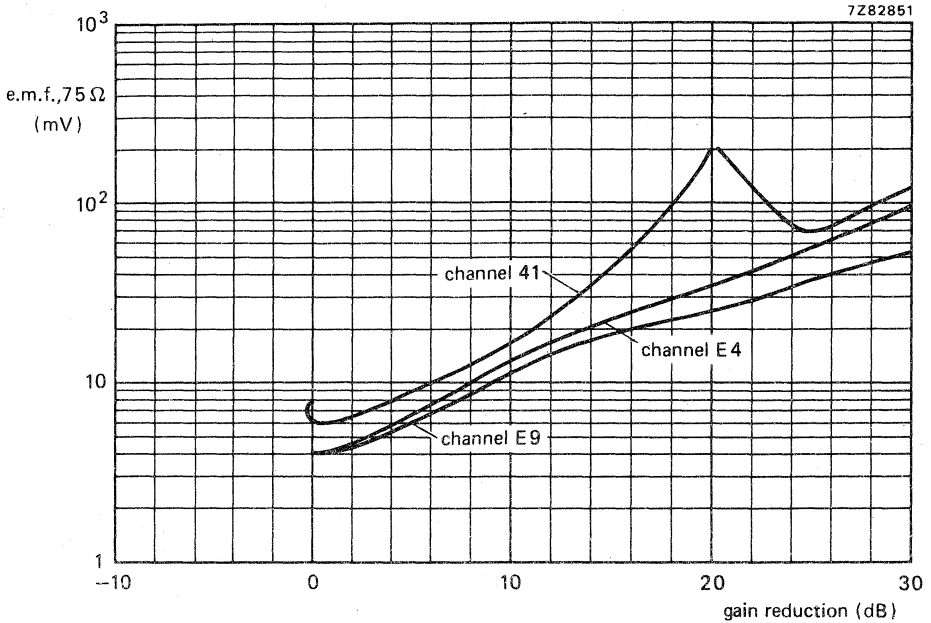

Fig. 11 Cross-modulation, in channel.

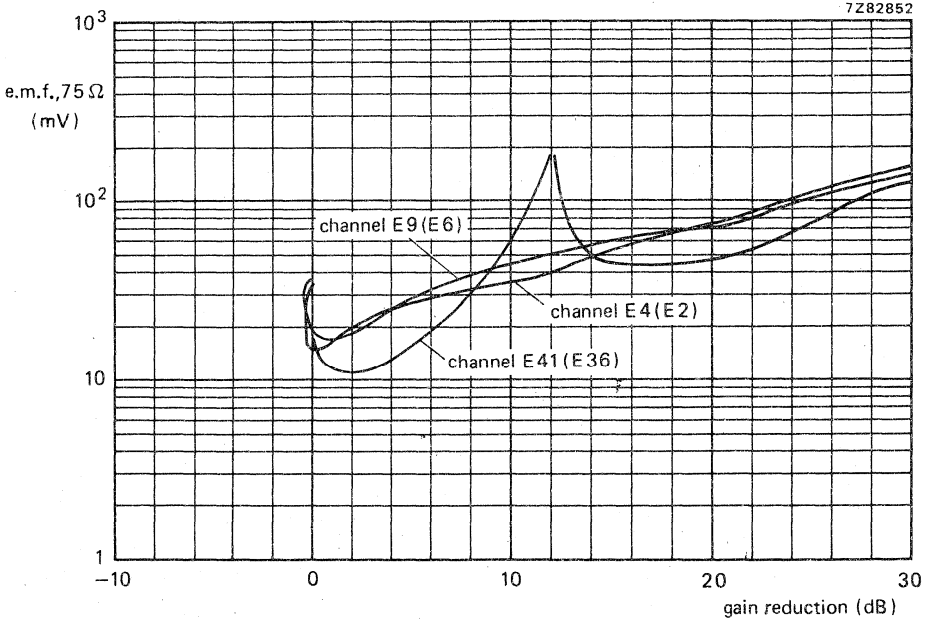

Fig. 12 Cross-modulation, in band; the interfering channels are given between brackets.

Oscillator characteristics

Shift of oscillator frequency

at a change of the supply voltage of 10%

low v.h.f. band	max. 500 kHz
high v.h.f. band	max. 600 kHz
u.h.f. band	max. 600 kHz

at a gain reduction of 30 dB

max. 100 kHz

Drift of oscillator frequency during warm-up time

(measured between 5 s and 15 min after switching on)

low v.h.f. band	max. 250 kHz
high v.h.f. band	max. 250 kHz
u.h.f. band	max. 250 kHz

Drift of oscillator frequency at a change of ambient temperature from 25 to 40 °C

low v.h.f. band	max. 400 kHz
high v.h.f. band	max. 400 kHz
u.h.f. band	max. 500 kHz

I.F. circuit characteristics

Detuning of the i.f. output circuit as a result of

r.f. tuning and band switching (reference:

channel E8), except channel E2

max. 400 kHz

channel E2

max. 550 kHz

Miscellaneous

Oscillator radiation and oscillator voltage at the aerial terminal.

The tuner is in conformity with the radiation requirements of C.I.S.P.R. 13 (1975) and VDE0872/7.72, provided the following conditions are fulfilled:

- A low-pass filter (Fig. 13) with a cut-off frequency of about 300 MHz has to be inserted between the v.h.f. aerial terminal of the tuner and the aerial terminal of the receiver, and a high-pass filter (Fig. 14) with a cut-off frequency of 350 MHz between the u.h.f. aerial terminal of the tuner and the aerial terminal of the receiver.

Television receivers with a common v.h.f./u.h.f. connector in combination with a low-pass/high-pass splitter do not need these additional filters.



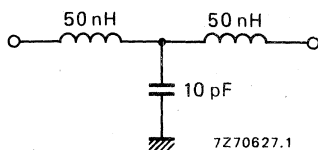

Fig. 13.

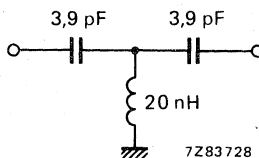

Fig. 14.

- No connections must be made to terminals 7, 9 and 11.
- Earthing of the tuner and connections to the i.f. amplifier has to be done in such a way, that additional radiation is prevented.

Microphonics

If the tuner is installed in a professional manner, there will be no microphonics.

Surge protection

Protection against voltages

max. 5 kV

Note: Three discharges of a 470 pF capacitor into the aerial terminal.

Protection against flashes

max. 30 kV, 400 mWs

Note: A flash-over circuit producing flashes with frequencies of 1 to 20 Hz for 30 s is connected to the aerial terminal.

APPLICATION INFORMATION

Connection of the tuner

For connection of the tuner the terminal location, Fig. 2, should be consulted. If the tuner is used in receivers the chassis of which is connected to the mains, isolating capacitors according to the safety rules have to be inserted in the aerial leads. A convenient way of connecting is given below.

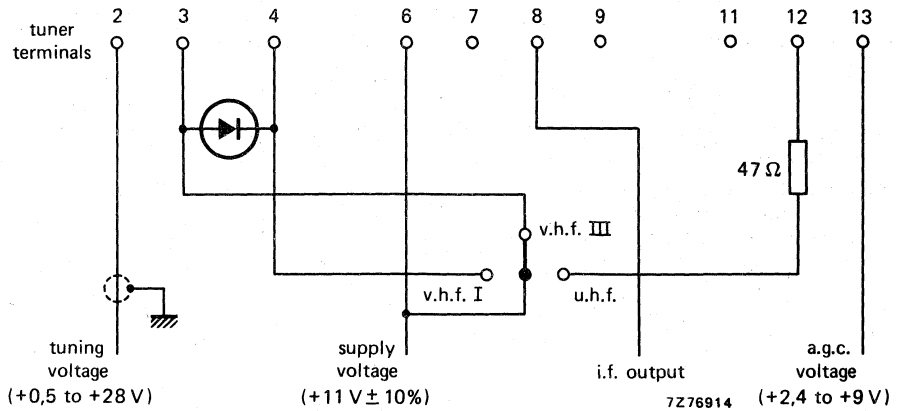

Fig. 15 Connection diagram; diode BAX13, BA217 or comparable silicon diode is used.

Alignment of the i.f. circuit

The tuner is provided with a test point at the collector of the v.h.f. mixer, which can be used for i.f. injection to align the i.f. output circuit. The i.f. signal should be fed to test point 1 (terminal 7) via a capacitor of 0,5 to 1 pF (Fig. 16). This capacitor should have short leads to avoid oscillator radiation. After alignment it should be soldered to earth, to avoid detuning of the i.f. circuit (Fig. 17).

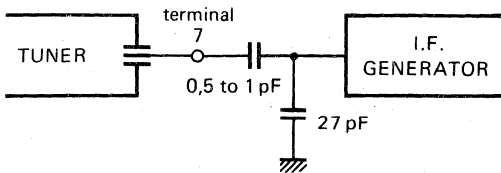

Fig. 16.

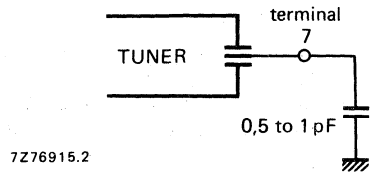

Fig. 17.

In receivers where the tuner is soldered into a printed-wiring board, the capacitor can be printed as shown in Figs 18 and 19.

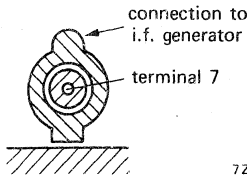

Fig. 18.

7Z76913

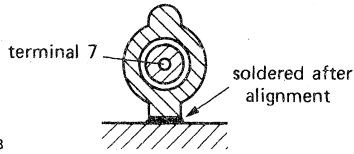

Fig. 19.

The aligning should be done with the v.h.f. III band tuned. The tuning voltage should be 15 to 20 V. If this injection method cannot be employed in the television receiver (e.g. there is not enough i.f. signal available) the i.f. signal can be fed to test point 3 (terminal 11) via a capacitor of 0,82 to 1 pF. The tuner must be switched to the u.h.f. position; the tuning voltage should be approx. 10 V. This injection method requires approx. 14 dB less signal than the first method. The capacitor has to be removed after alignment. No permanent connection must be made to test point 3, otherwise the tuner may exceed the oscillator radiation limits.

MEASURING METHOD OF POWER GAIN

The i.f. output of the tuner should be terminated with the circuit given in Fig. 20. The terminals 7, 9 and 11 should be not connected.

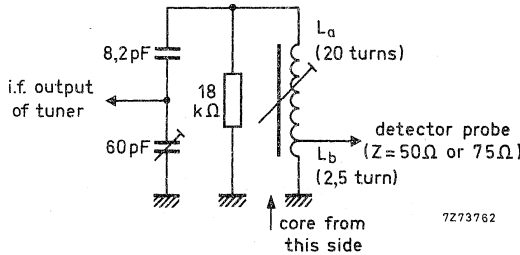

Fig. 20.

Alignment of this circuit in connection with the tuner is done as follows. Switch the tuner to the v.h.f. III band; the tuning voltage should be 15 to 20 V. Feed an i.f. sweep signal (e.m.f. 500 to 1000 mV) to test point 1 as given in Alignment of the i.f. circuit. Adjust the trimmer (Fig. 20), tunable coil (L_a/L_b), i.f. output coil of the tuner L519 (Fig. 1) and the coupling between L_a and L_b to get the resonant curve as given in Fig. 21.

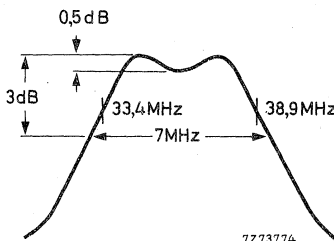

Fig. 21.

Then display the r.f. + i.f. curve of the tuner at 190 MHz (picture carrier frequency) and make small corrections in the alignment of the i.f. coils (L_a/L_b and L519), if necessary, to get the 38,9 MHz and 33,4 MHz markers symmetrically on the slopes of the curve and the peaks at equal amplitude.

Because the output impedance of the dummy circuit is 50 to 75 Ω , the power gain can be measured in the conventional manner by inserting tuner and dummy circuit between a 75 Ω source and a 75 Ω detector (or between a 50 Ω source and matching pad 50/75 Ω and a 50 Ω detector).

ACCESSORIES

Aerial input transformer ELC1094, v.h.f., catalogue number: 2422 542 10941.

Aerial input transformer ELC2092, u.h.f., catalogue number: 2422 542 12921.

Coaxial aerial input assembly, with safety capacitors, catalogue number: 3122 127 10450.

Coaxial aerial input assembly, without safety capacitors, catalogue number: 3122 128 57720.

Immunity shield, v.h.f., catalogue number 3122 121 28830.

Immunity shield, u.h.f., catalogue number 3122 121 28840.

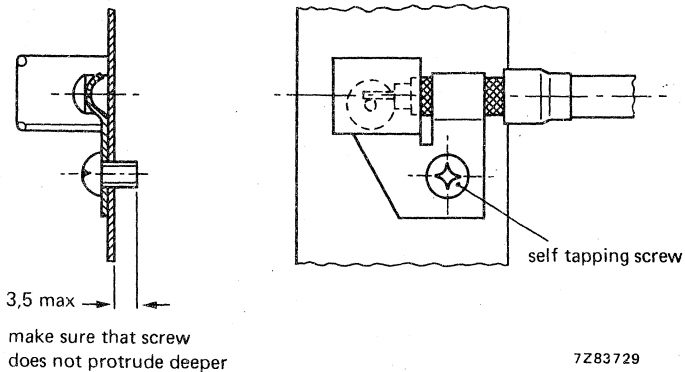

Fig. 22 Fixing method of immunity shield; see Fig. 4 for cable cut.

V.H.F./U.H.F. TELEVISION TUNER

with diode tuning

QUICK REFERENCE DATA	
Systems	C. C. I. R. systems B and G
Channels ¹⁾	0 to 4 (low v. h. f. band) 5 to 11 (high v. h. f. band) 28 to 63 (u. h. f. band)
Intermediate frequencies	
picture	36,875 MHz
sound	31,375 MHz

APPLICATION

Designed to cover the Australian v. h. f. and u. h. f. channels of C. C. I. R. systems B and G.

¹⁾ In accordance with the publications of the Australian Broadcasting Control Board (ABCB).

DESCRIPTION

The ELC2060 is a combined v.h.f./u.h.f. tuner with electronic tuning and band switching, covering the low v.h.f. band with the channels 0 to 4 (frequency range 45 to 101 MHz), the high v.h.f. band with the channels 5 to 11 (frequency range 101 to 222 MHz), and the u.h.f. band with the channels 28 to 63 (frequency range 526 to 814 MHz).

Mechanically, the tuner is built on a low-loss printed-wiring board, carrying all components, in a metal housing made of a rectangular frame and front and rear cover (see Fig. 2). The two aerial connections (v.h.f. and u.h.f.) are on the two frame sides, all other connections (supply voltages, a.g.c. voltage, tuning and switching voltages) are made via feed-through capacitors in the under side. The mounting method is shown in Figs. 3 and 4.

Electrically, the tuner consists of v.h.f. and u.h.f. parts. The v.h.f. aerial signal is fed via an i.f. trap, combined with a high-pass filter, to a tuned input circuit, which is connected to the emitter of the input transistor BF200. The collector load of this transistor is formed by a double tuned circuit, transferring the signal to the base of the mixer transistor BF183. The oscillator is equipped with a transistor BF494. The four r.f. circuits are tuned by four capacitance diodes BB109G. A capacitance diode BB106 provides a frequency-dependent coupling of the r.f. input signal to the tuned input circuit. Switching between the low and high v.h.f. bands is done by four switching diodes (BA182, BA243, and BA244).

The collector circuit of the mixer transistor is a single tuned i.f. resonant circuit, at the low end of which the i.f. signal is capacitively coupled out of the tuner (low capacitance coupling). An i.f. injection point is provided at the collector of the mixer, for aligning this circuit together with the i.f. amplifier of the television receiver.

The u.h.f. part of the tuner consists of a tuned input circuit, connected to the emitter of the amplifier transistor BF183. The inter-stage network between this transistor and the self-oscillating mixer stage is formed by a double tuned circuit. A transistor BF181 acts as a self-oscillating mixer. The four tuned u.h.f. circuits are tuned by four capacitance diodes BB105B.

The output of the self-oscillating mixer is fed to a double tuned i.f. circuit which is connected to the emitter of the v.h.f. mixer transistor BF183, now operating as an i.f. amplifier in grounded-base configuration. Band switching between v.h.f. and u.h.f. is achieved by a diode BA243.

The tuner requires transistor supply voltages of +12 V, a switching voltage of +12 V, a.g.c. voltages, variable from +2,4 V (normal operating point) to about +7,5 V (maximum a.g.c.) and a tuning voltage, variable from +0,5 V to +28 V.

The aerial inputs of the tuner are asymmetrical. For use in symmetrical aerial systems, aerial transformers (baluns) are available (see ACCESSORIES).

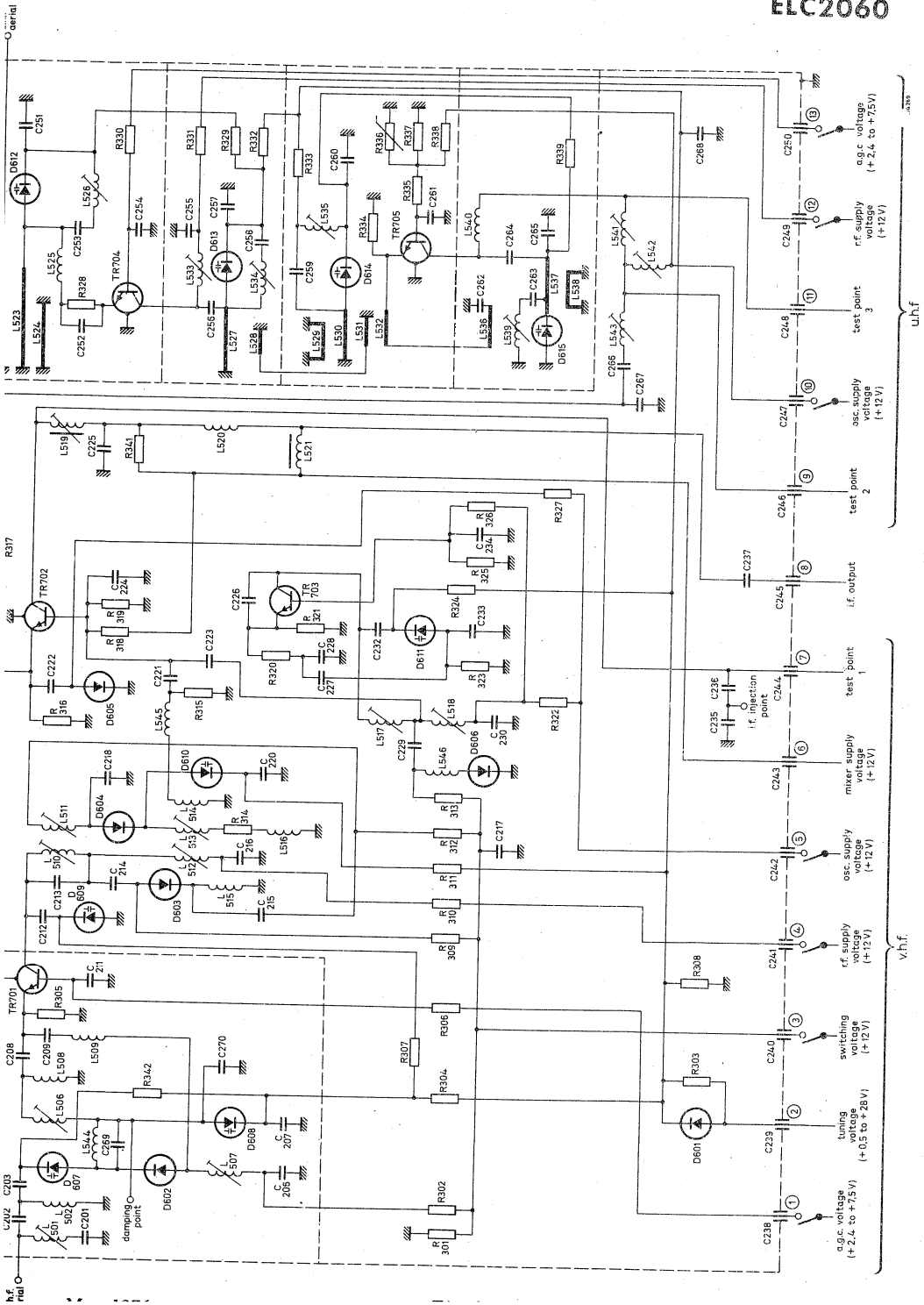

MECHANICAL DATA

Dimensions in mm

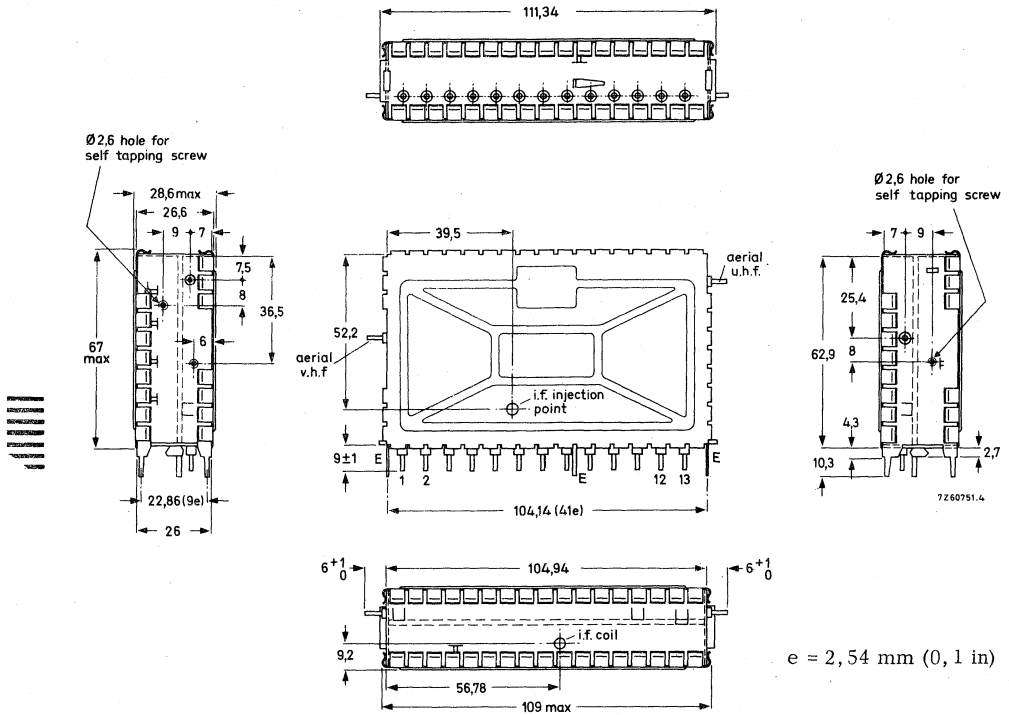

e = 2,54 mm (0,1 in)

Fig.2.

- Terminal 1 = a.g.c. voltage, v.h.f., +2,4 to +7,5 V
 2 = tuning voltage, +0,5 to +28 V
 3 = switching voltage, +12 V (approx. 22 mA)
 4 = r.f. supply voltage, v.h.f., +12 V (approx. 3 to 10 mA)
 5 = oscillator supply voltage, v.h.f., +12 V (approx. 6 mA)
 6 = mixer supply voltage, v.h.f., +12 V (approx. 5 mA)
 7 = test point 1, v.h.f.
 8 = i. f. output
 9 = test point 2 (alignment short)
 10 = oscillator supply voltage, u.h.f., +12 V (approx. 4,8 mA)
 11 = test point 3, u.h.f.
 12 = r.f. supply voltage, u.h.f., +12 V (approx. 2,5 to 9,5 mA)
 13 = a.g.c. voltage, u.h.f., +2,4 to +7,5 V
 E = earth

Mounting

The tuner may be mounted by soldering it on to a printed-wiring board, using the piercing diagram shown in Fig. 3. (The tuner may also be mounted by means of a snap-in mount or a bracket. Information will be supplied upon request.)
The tuner may be mounted anywhere in the receiver and there are no restrictions on orientation.

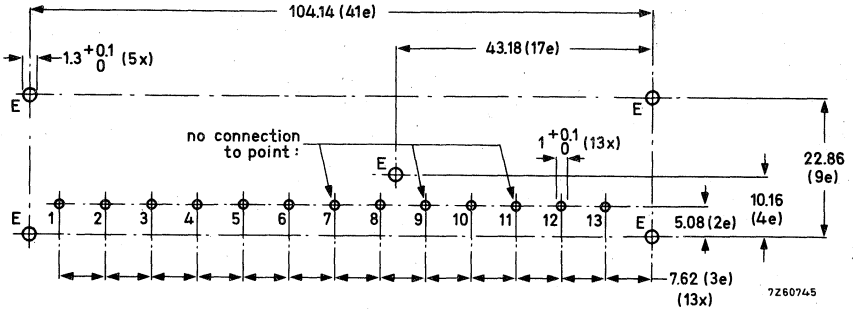

Fig. 3. Piercing diagram viewed from solder side of board; e = 2,54 mm (0,1 in).
No connection must be made to the points 7, 9 and 11, otherwise the oscillator radiation may increase.

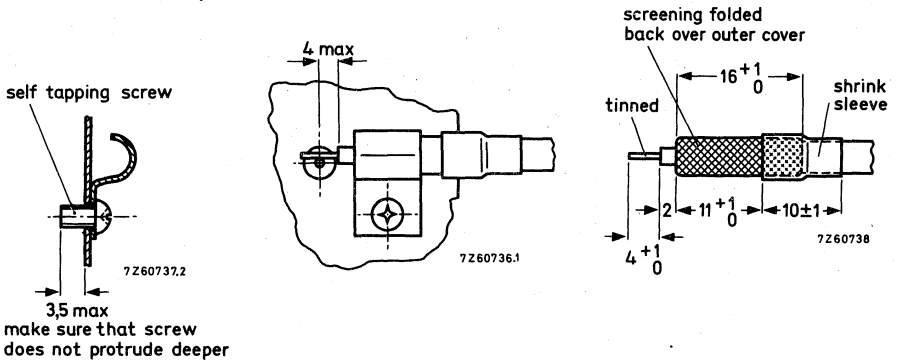

Fig. 4. Recommended fixing method of the aerial cables. Use a self-tapping screw.

ELECTRICAL DATA

Unless otherwise specified all electrical values apply at an ambient temperature of 25 ± 5 °C and a supply voltage of $12 \pm 0,3$ V.

Semiconductors

v.h.f. bands, r.f. amplifier	BF200
mixer	BF183
oscillator	BF494
tuning diodes	4 x BB109G
coupling diode	BB106
switching diodes	2 x BA182; 1 x BA243; 2 x BA244
u.h.f. band, r.f. amplifier	BF180
mixer/oscillator	BF181
tuning diodes	4 x BB105B
drift compensating diode	BAW62

Ambient temperature range

operating	+5 to +55 °C
storage	-25 to +85 °C

Relative humidity

max. 90%

Supply voltage

+12 V +10%, -15%

Current drawn from +12 V supply

low v.h.f. band	14 to 21 mA	} depending on a.g.c. voltage
high v.h.f. band	36 to 43 mA	
u.h.f. band	33,5 to 40 mA	

A.G.C. voltage (Figs. 5, 6 and 7)

low v.h.f. band, at nominal gain	2,4 V
at 40 dB gain reduction	typ. 5,5 V
high v.h.f. band, at nominal gain	2,4 V
at 40 dB gain reduction	typ. 4,5 V
u.h.f. band, at nominal gain	2,4 V
at 30 dB gain reduction	typ. 5,0 V

A.G.C. current

low v.h.f. band	} at 40 dB gain reduction	max. 0,8 mA
high v.h.f. band		max. 0,6 mA
u.h.f. band, at 30 dB gain reduction		max. 0,7 mA

Tuning voltage range (Figs. 8, 9 and 10)

+0,5 to +28 V

Current drawn from 28 V tuning voltage supply

max. 36 μ A

Note: The source impedance of the tuning voltage offered to terminal 2, must be max. 30 k Ω at tuning voltages below 2 V.

Switching voltage

low v.h.f. band	open circuit
high v.h.f. band	+12 V
u.h.f. band	+12 V

Note: In the low v.h.f. band position, the tuner produces a negative voltage (1 to 5 V) at terminal 3; this terminal must not be loaded with an external resistance below 20 M Ω .

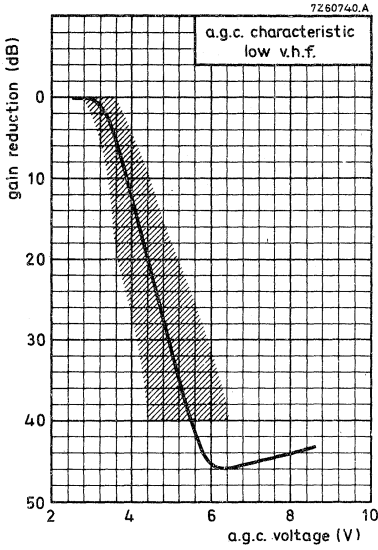

Fig. 5

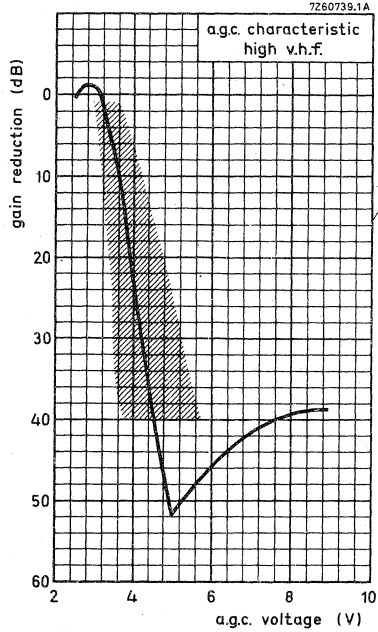

Fig. 6.

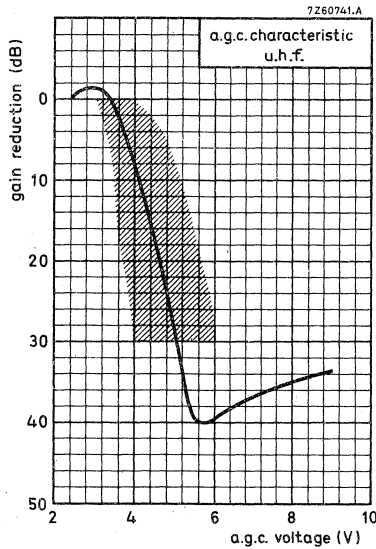

Fig. 7.

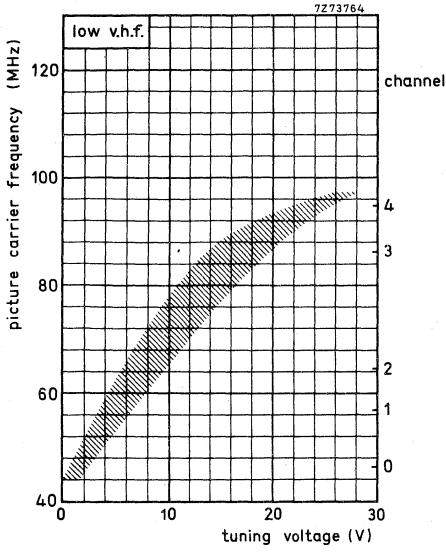

Fig. 8.

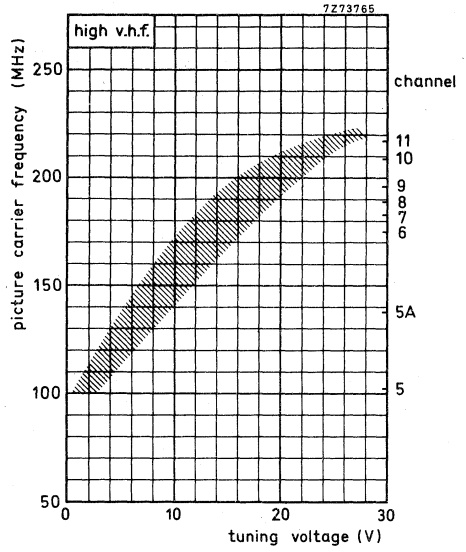

Fig. 9.

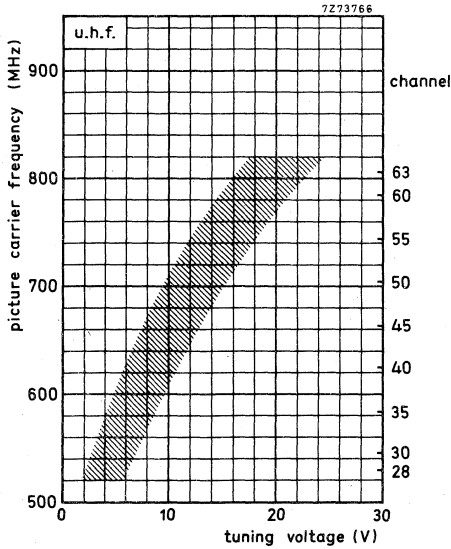

Fig. 10.

Frequency ranges				
low v. h. f. band		channel 0 (picture carrier 46,25 MHz)		
		to channel 4 (picture carrier 95,25 MHz).		
		Margin at the extreme channels: min.		
		1,5 MHz.		
high v. h. f. band		channel 5 (picture carrier 102,25 MHz)		
		to channel 11 (picture carrier 216,25 MHz).		
		Margin at the extreme channels: min.		
		2 MHz.		
u. h. f. band		channel 28 (picture carrier 527,25 MHz)		
		to channel 63 (picture carrier 807,25 MHz).		
		Margin at the extreme channels: min.		
		3 MHz.		
Intermediate frequencies				
picture		36,875 MHz		
sound		31,375 MHz		
		The oscillator frequency is higher than the		
		input-signal frequency.		
Input impedance				
asymmetrical		75 Ω		
symmetrical		300 Ω (see ACCESSORIES)		
V.S.W.R. (between picture carrier		v. s. w. r. at nom.	max. v. s. w. r.	
and sound carrier)		gain	during gain control	
		min. 1) max. 2)	min. 1 max. 2)	
low v. h. f. band		max. 3 max. 5	max. 4 max. 5,5	
high v. h. f. band, channels 5A to 11		max. 4 max. 5	max. 4,5 max. 5,5	
channel 5		max. 4 max. 6	max. 4,5 max. 6	
u. h. f. band		max. 4	max. 5	
A.G.C. range				
low v. h. f. band		min. 40 dB		
high v. h. f. band		min. 40 dB		
u. h. f. band		min. 30 dB		

1) Best value of V.S.W.R. between picture carrier and sound carrier.

2) Worst value of V.S.W.R., between picture carrier and sound carrier.

R.F. curves at nominal gain	
bandwidth, low v.h.f. band	typ. 9 to 13 MHz
high v.h.f. band	typ. 9 to 14 MHz
u.h.f. band	typ. 13 to 18 MHz
tilt, low v.h.f. band	max. 3 dB
high v.h.f. band, channels 5 and 5A	max. 3,5 dB
channels 6 to 11	max. 3 dB
u.h.f. band	max. 3 dB
Power gain (see also MEASURING METHODS)	
v.h.f. bands, except channel 5	min. 25 dB
channel 5	min. 21 dB
channel 0	typ. 31 dB
channel 4	typ. 29 dB
channel 5	typ. 24 dB
channel 8	typ. 29 dB
u.h.f. band	min. 25 dB
channel 28	typ. 30 dB
channel 63	typ. 32 dB
Noise figure	
low v.h.f. band	max. 9 dB
channel 0	typ. 7 dB
channel 4	typ. 7 dB
high v.h.f. band	
channel 5	max. 11 dB
	typ. 9 dB
channel 5A	max. 8,5 dB
	typ. 6,5 dB
channels 6 to 11	max. 8 dB
	typ. 5 dB
u.h.f. band	max. 12 dB
channel 28	typ. 8,5 dB
channel 63	typ. 9,5 dB
I.F. rejection	
v.h.f. bands, channel 0	min. 40 dB
channels 1 and 2	min. 50 dB
channels 3 to 11	min. 60 dB
u.h.f. band	min. 60 dB
Image rejection	
low v.h.f. band	min. 50 dB
high v.h.f. band	min. 60 dB
u.h.f. band	min. 40 dB

Signal handling (see also Figs. 12 and 13)

Minimum input signal (e. m. f.) producing
cross-modulation (1%) at nominal
gain, in channel

(wanted signal: picture carrier frequency,
interfering signal: sound carrier
frequency), low v. h. f. band
high v. h. f. band
u. h. f. band

typ. 4 mV
typ. 4 mV
typ. 5 to 10 mV } 1)

in band

(wanted signal: picture carrier frequency
of channel N,
interfering signal: picture carrier of
channel N-2 (v. h. f.), N-5 (u. h. f.))

low v. h. f. band
high v. h. f. band
u. h. f. band

typ. 15 to 60 mV
typ. 10 to 50 mV
typ. 15 to 50 mV } 1)

Minimum input signal (e. m. f.) producing
overloading, at nominal gain
at maximum a. g. c.

typ. 10 mV
typ. >200 mV } 2)

Minimum input signal (e. m. f.) at nominal
gain producing a shift of the oscillator
frequency of 10 kHz, low v. h. f. band
high v. h. f. band
u. h. f. band

typ. 25 mV
typ. 25 mV
typ. 10 to 20 mV } 3)

Tuning range of the i. f. output circuit (see
also MEASURING METHODS)

max. 31,5 to min. 37,5 MHz

Detuning of the i. f. output circuit as a result of
band switching and tuning with respect of channel 8

max. 400 kHz

Shift of oscillator frequency

at a change of the supply voltage of 10%

v. h. f. bands, channels 0 to 4

channels 5 to 11

u. h. f. band

max. 500 kHz
max. 300 kHz
max. 600 kHz

at a gain reduction of 30 dB

max. 100 kHz

1) This e. m. f. (open voltage) is referred to an impedance of 75 Ω.

1% cross-modulation means that 1% of the modulation depth of the interfering signal is transferred to the wanted signal.

2) This e. m. f. (open voltage) is referred to an impedance of 75 Ω.

Criterion of overloading: 30% compression of the synchronization pulses of a standard television signal or a noticeable deterioration of the picture quality.

3) This e. m. f. (open voltage) is referred to an impedance of 75 Ω.

Drift of oscillator frequency

during warm-up time (measured between 5 s
and 15 min after switching on)

v. h. f. bands	max. 200 kHz
u. h. f. band	max. 250 kHz

at a change of the ambient temperature
from 25 to 50 °C

v. h. f. bands	max. 500 kHz
u. h. f. band	max. 1000 kHz

Oscillator radiation

The tuner is in conformity with the radiation requirements of the Australian Standard AS 1053-1973 and of C.I.S.P.R. Recommendation No. 24/3, provided the following conditions are fulfilled:

- A low-pass filter (Fig. 11) with a cut-off frequency of about 300 MHz has to be inserted between the v. h. f. aerial terminal of the tuner and the aerial terminal of the receiver. Television receivers with a common v. h. f. /u. h. f. connector in combination with a low-pass/high-pass splitter ¹⁾ may not need this additional filter.

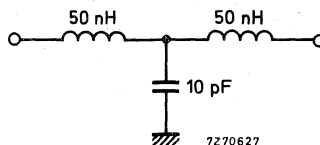

Fig. 11.

- No connections must be made to the terminals 7, 9 and 11.
- Earthing of the tuner and connections to the i. f. amplifier have to be made in such a way, that additional radiation is prevented.

Microphonics

If the tuner is installed in a professional manner, there will be no microphonics.

¹⁾ E. g. coaxial aerial input assembly 3122 127 10450.

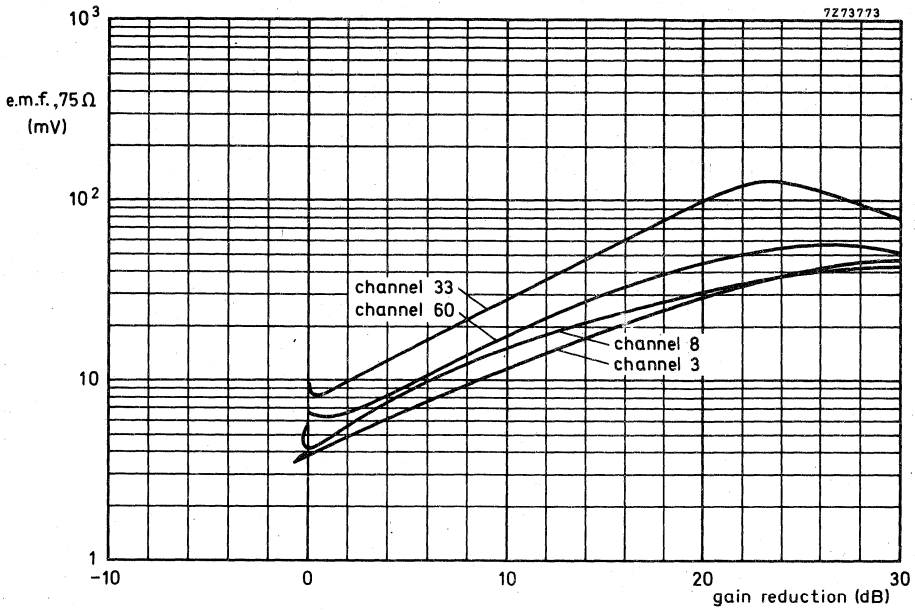

Fig. 12. Cross-modulation, in channel.

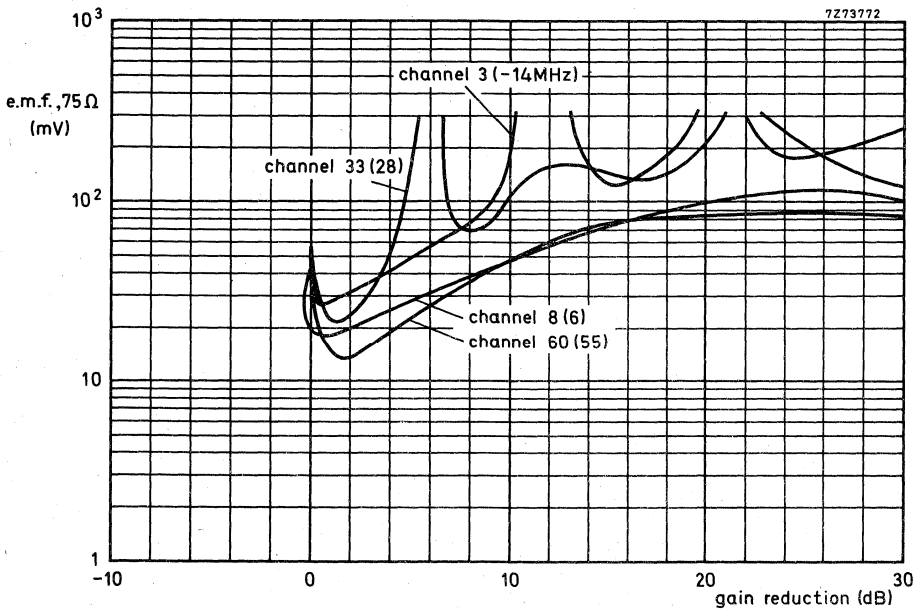

Fig. 13. Cross-modulation, in band; the interfering channels are given between brackets.

APPLICATION INFORMATION

Connection of the tuner

For connection of the tuner the terminal location, Fig. 2, should be consulted. If the tuner is used in receivers the chassis of which is connected to the mains, isolating capacitors according to the safety rules have to be inserted in the aerial leads. Five ways of connecting, depending on the number of switches available, are given below.

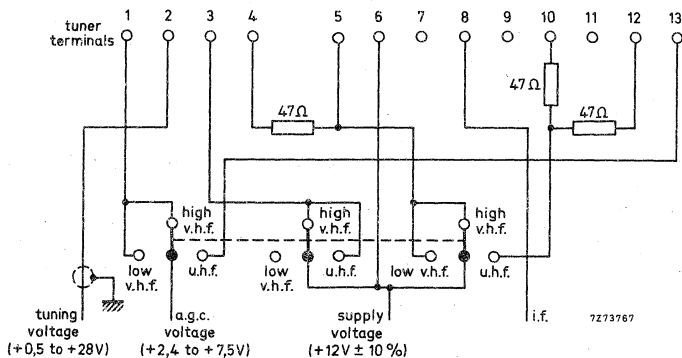

Fig. 14. Connection diagram with three switches.

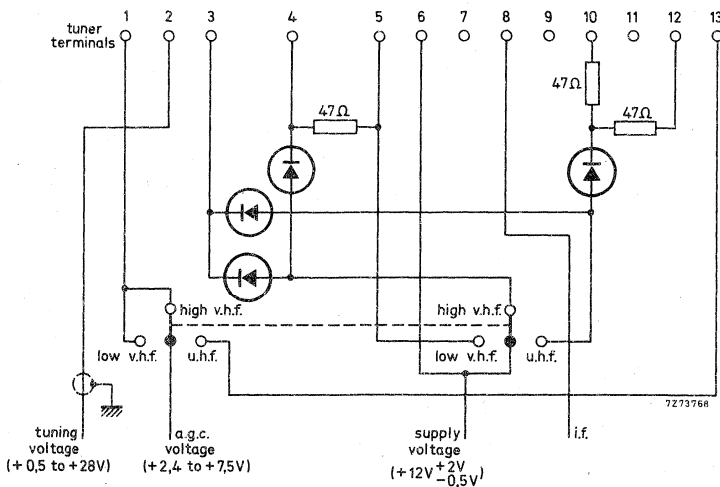

Fig. 15. Connection diagram with two switches.

All diodes : BAX13, BA217 or comparable silicon diodes.

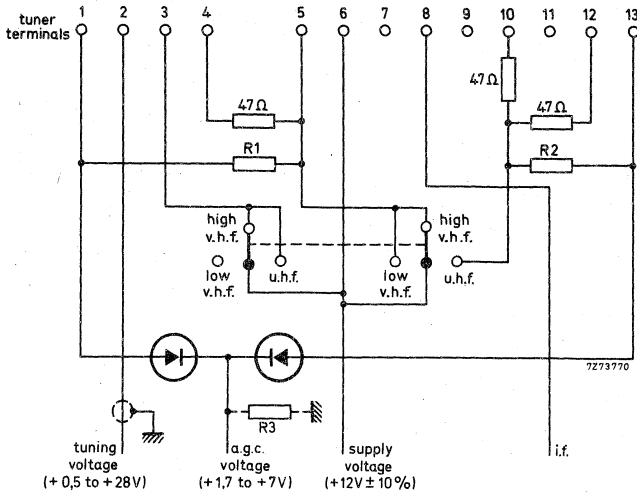

Fig. 16. Connection diagram with two switches.
All diodes: BAX13, BA217 or comparable silicon diodes.
The values of R₁, R₂ and R₃ depend on a.g.c. circuit.

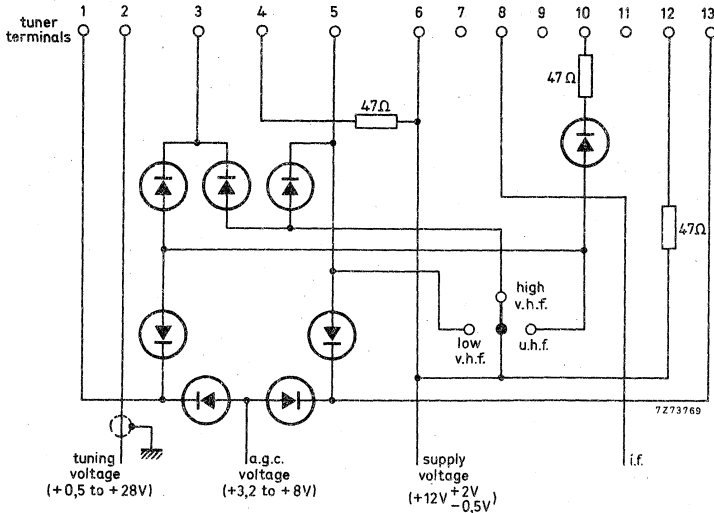

Fig. 17. Connection diagram with one switch.
All diodes: BAX13, BA217 or comparable silicon diodes.

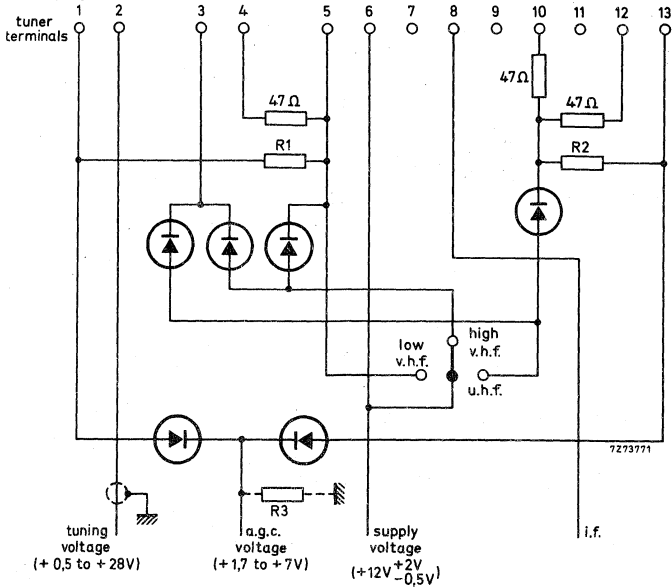

Fig. 18. Connection diagram with one switch.
All diodes : BAX13, BA217 or comparable silicon diodes.
The values of R₁, R₂ and R₃ depend on a.g.c. circuit.

Alignment of the i. f. circuit

The tuner is provided with an i. f. injection point at the collector of the mixer for aligning the i. f. circuit together with the i. f. amplifier of the television receiver (for the position of the i. f. injection point see Fig. 2).

The alignment should be done with the high v. h. f. band tuned. The tuning voltage should be 15 to 20 V.

If this injection method cannot be employed in the television receiver (e.g. because the injection point is not accessible or there is not enough i. f. signal available), the i. f. signal can be fed to test point 3 (terminal 11) via a capacitor of 0,82 to 1 pF. The tuner must be switched to the u. h. f. position; the tuning voltage should be approx. 10 V. This injection method requires approx. 14 dB less signal than the first method. No permanent connection must be made to test point 3, otherwise the tuner may exceed the oscillator radiation limits.

MEASURING METHODS

Power gain

The i. f. output of the tuner should be terminated with the dummy circuit given below. The terminals 7, 9 and 11 should be not connected.

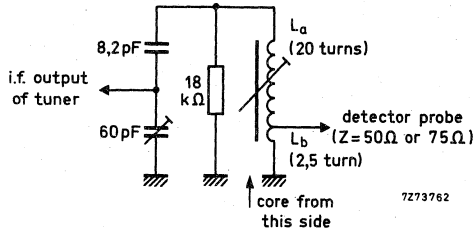

Fig. 19.

The dummy circuit should be aligned as follows.

Switch the tuner to the high v. h. f. band; the tuning voltage should be 15 to 20 V.

Feed an i. f. sweep signal (500 to 1000 mV) to the i. f. injection point.

Adjust the trimmer (Fig. 19), tunable coil (L_a/L_b), i. f. output coil of the tuner L519 (Fig. 1) and the coupling between L_a and L_b to get the resonant curve as given below.

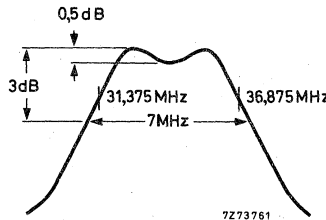

Fig. 20.

Then display the r. f. + i. f. curve of the tuner at 190 MHz (picture carrier frequency) and make small corrections in the alignment of the i. f. coils (L_a/L_b and L519), if necessary, to get the markers 36, 875 MHz and 31, 375 MHz symmetrically on the slopes of the curve, and the peaks at equal amplitude.

Because the output impedance of the dummy circuit is 50 to 75 Ω, the power gain can be measured in the conventional manner by inserting tuner and dummy circuit between a 75 Ω source and a 75 Ω detector (or between a 50 Ω source and matching pad 50/75 Ω and a 50 Ω detector).

Tuning range of i. f. output circuit

The i. f. output of the tuner should be terminated with the circuit given in Fig. 21. The terminals 7, 9 and 11 should not be connected.

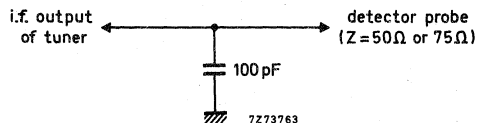

Fig. 21.

ACCESSORIES

Aerial input transformer ELC1094, v.h.f., catalogue number : 2422 542 10941;
aerial input transformer ELC2092, u.h.f., catalogue number : 2422 542 12921;
coaxial aerial input assembly, catalogue number : 3122 127 10450.

V.H.F./U.H.F. TELEVISION TUNER with diode tuning

QUICK REFERENCE DATA

System	C.C.I.R. system I
Channels (South African channel distribution)	4 to 13 (v.h.f. band) 21 to 69 (u.h.f. band)
Intermediate frequencies	
picture	38,9 MHz
sound	32,9 MHz

APPLICATION

Designed to cover the South African v.h.f. and u.h.f. channels of C.C.I.R. system I.



DESCRIPTION

The ELC2070 is a combined v. h. f. /u. h. f. tuner with electronic tuning and band switching, covering the South African v. h. f. band (frequency range 174 to 254 MHz) and the u. h. f. band (frequency range 470 to 860 MHz).

Mechanically, the tuner is built on a low-loss printed-wiring board, carrying all components, in a metal housing made of a rectangular frame and front and rear cover (see Fig. 2). The two aerial connections (v. h. f. and u. h. f.) are on the two frame sides, all other connections (supply voltages, a. g. c. voltage and tuning voltage) are made via feed-through capacitors in the under side. The mounting method is shown in Figs. 3 and 4.

Electrically, the tuner consists of v. h. f. and u. h. f. parts. The v. h. f. aerial signal is fed via an i. f. trap, combined with a high-pass filter, to a tuned input circuit, which is connected to the emitter of the input transistor BF200. The collector load of this transistor is formed by a double tuned circuit, transferring the signal to the base of the mixer transistor BF182. The oscillator is equipped with a transistor BF494. The four r. f. circuits are tuned by four capacitance diodes BB106.

The collector circuit of the mixer transistor is a single tuned i. f. resonant circuit, at the low end of which the i. f. signal is capacitively coupled out of the tuner.

An i. f. injection point is provided at the collector of the mixer, for aligning this circuit together with the i. f. amplifier of the television receiver.

The u. h. f. part of the tuner consists of a tuned input circuit, connected to the emitter of the amplifier transistor BF180. The inter-stage network between this transistor and the self-oscillating mixer stage is formed by a double tuned circuit. A transistor BF181 acts as a self-oscillating mixer. The four tuned u. h. f. circuits are tuned by four capacitance diodes BB105B.

The output of the self-oscillating mixer is fed to a double tuned i. f. circuit which is connected to the emitter of the v. h. f. mixer transistor BF182, now operating as an i. f. amplifier in grounded-base configuration. Band switching between v. h. f. and u. h. f. is achieved by a diode BA243.

The tuner requires transistor supply voltages of +12 V, a. g. c. voltages, variable from +2, 4 V (normal operating point) to about +7, 5 V (maximum a. g. c.), and a tuning voltage, variable from +0, 5 V to +28 V.

The aerial inputs of the tuner are asymmetrical. For use in symmetrical aerial systems, aerial transformers (baluns) are available (see ACCESSORIES).

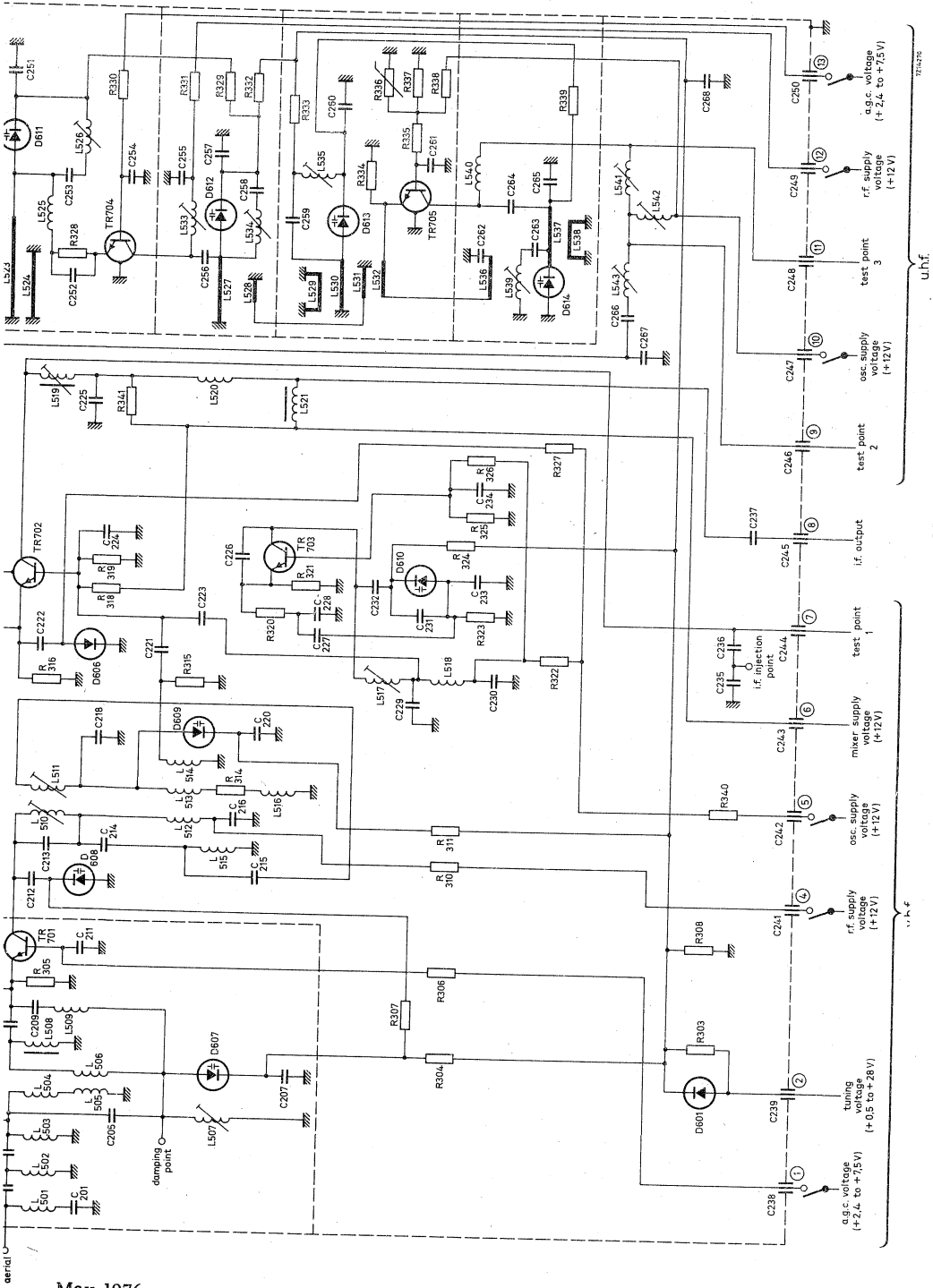

MECHANICAL DATA

Dimensions in mm

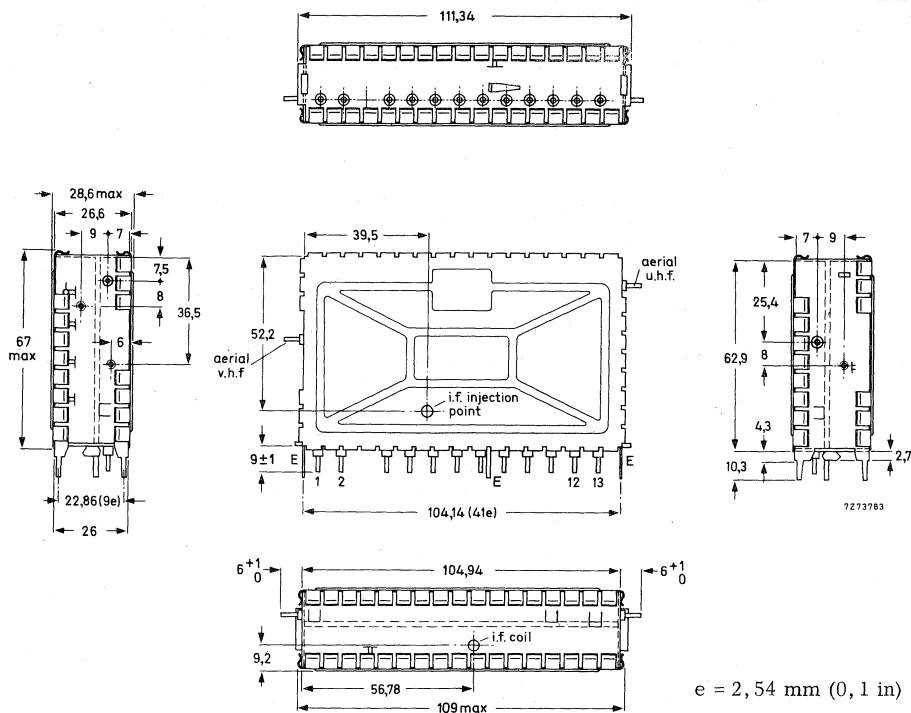

Fig. 2

- Terminal 1 = a. g. c. voltage, v. h. f. , +2,4 to +7,5 V
- 2 = tuning voltage, +0,5 to +28 V
- 4 = r. f. supply voltage, v. h. f. , +12 V (approx. 3 to 10 mA)
- 5 = oscillator supply voltage, v. h. f. , +12 V (approx. 6 mA)
- 6 = mixer supply voltage, v. h. f. , +12 V (approx. 5 mA)
- 7 = test point 1, v. h. f.
- 8 = i. f. output
- 9 = test point 2 (alignment short)
- 10 = oscillator supply voltage, u. h. f. , +12 V (approx. 4,1 mA)
- 11 = test point 3, u. h. f.
- 12 = r. f. supply voltage, u. h. f. , +12 V (approx. 2,5 to 9,5 mA)
- 13 = a. g. c. voltage, u. h. f. , +2,4 to +7,5 V
- E = earth

Mounting

The tuner may be mounted by soldering it on to a printed-wiring board, using the piercing diagram shown in Fig. 3. (The tuner may also be mounted by means of a snap-in mount or a bracket. Information will be supplied upon request.) The tuner may be mounted anywhere in the receiver and there are no restrictions on orientation.

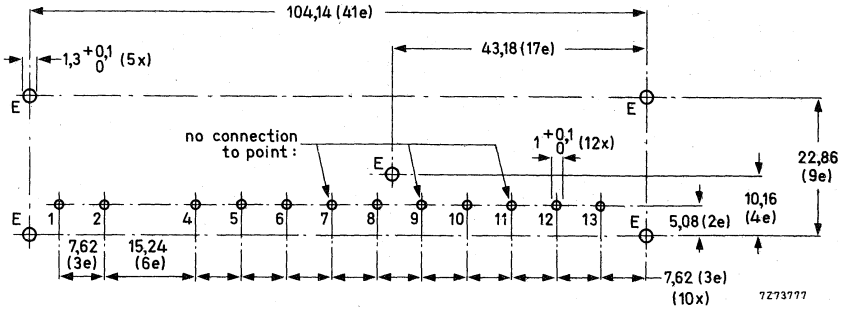

Fig. 3. Piercing diagram viewed from solder side of board; e = 2,54 mm (0,1 in). No connection must be made to the points 7, 9 and 11, otherwise the oscillator radiation may increase.

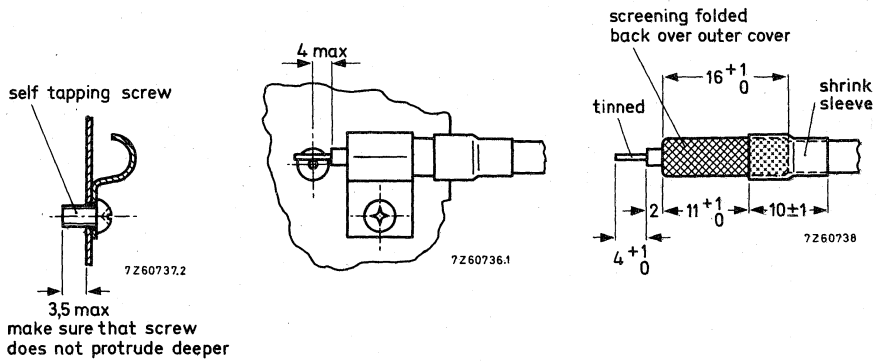

Fig. 4. Recommended fixing method of the aerial cables. Use a self-tapping screw.

ELECTRICAL DATA

Unless otherwise specified all electrical values apply at an ambient temperature of 25 ± 5 °C and a supply voltage of $12 \pm 0,3$ V.

Semiconductors

v. h. f. band, r. f. amplifier	BF200
mixer	BF182
oscillator	BF494
tuning diodes	4 x BB106
switching diode	BA243
u. h. f. band, r. f. amplifier	BF180
mixer/oscillator	BF181
tuning diodes	4 x BB105B
drift compensating diode	BAW62

Ambient temperature range

operating	+5 to +55 °C
storage	-25 to +85 °C

Supply voltage

Current drawn from +12 V supply	+12 V
---------------------------------	-------

v. h. f. band

14 to 21 mA

u. h. f. band

11,5 to 18 mA

} depending on
a. g. c. voltage

A. G. C. voltage (Figs. 5 and 6)

v. h. f. band, at nominal gain	2,4 V
at 40 dB gain reduction	typ. 4,5 V
u. h. f. band, at nominal gain	2,4 V
at 30 dB gain reduction	typ. 5,0 V

A. G. C. current

v. h. f. band, at 40 dB gain reduction	max. 0,6 mA
u. h. f. band, at 30 dB gain reduction	max. 0,7 mA

Tuning voltage range (Fig. 7 and 8)

Current drawn from 28 V tuning voltage supply	+0,5 to +28 V
	max. 36 µA

Frequency ranges

v. h. f. band	South African channel 4 (picture carrier 175,25 MHz) to channel 13 (picture carrier 247,43 MHz).
u. h. f. band	Margin at the extreme channels : min. 2 MHz. channel 21 (picture carrier 471,25 MHz) to channel 69 (picture carrier 855,25 MHz). Margin at the extreme channels : min. 3 MHz.

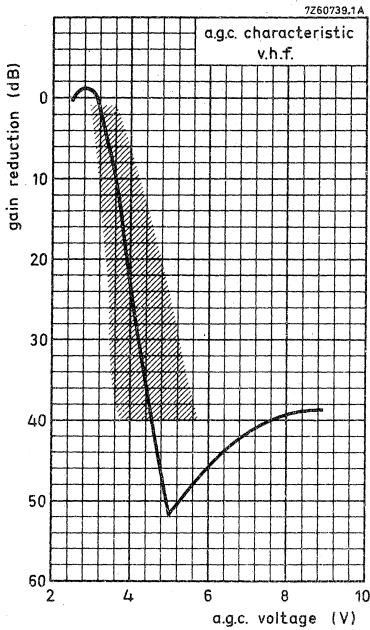

Fig. 5

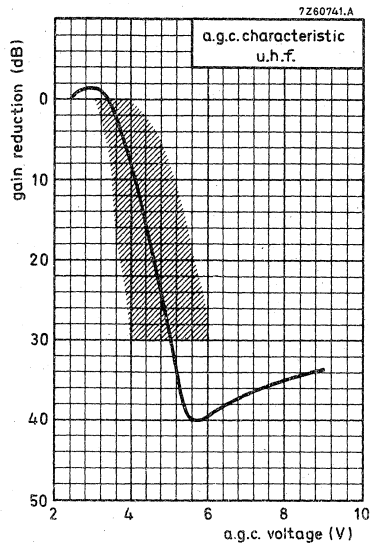

Fig. 6

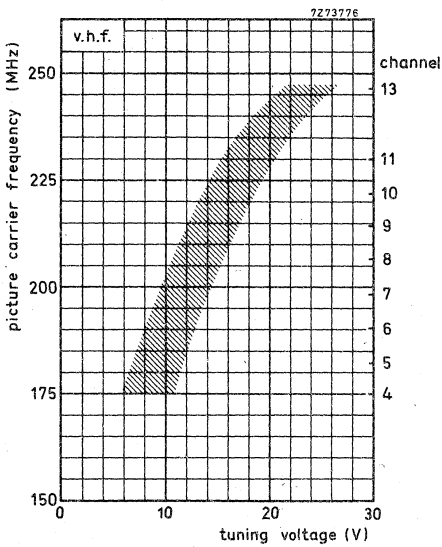

Fig. 7

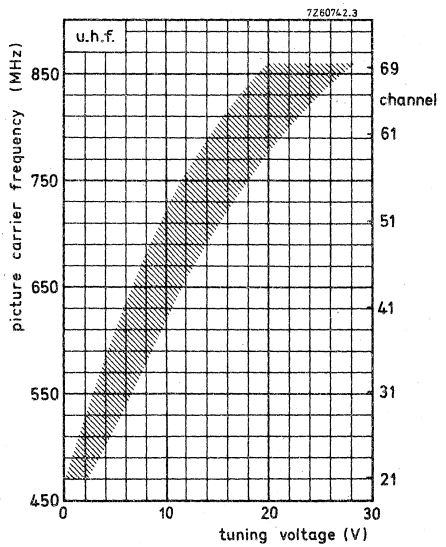

Fig. 8

Intermediate frequencies

picture	38,9 MHz
sound	32,9 MHz

Input impedance

asymmetrical	75 Ω
symmetrical	300 Ω (see ACCESSORIES)

V.S.W.R. (between picture carrier
and sound carrier)

	v. s. w. r. at nom. gain		max. v. s. w. r. during gain control	
	min. 1)	max. 2)	min. 1)	max. 2)
v. h. f. band, channels 4 to 9	max. 3,5	max. 5	max. 4	max. 5
channels 10 to 13	max. 3,5	max. 6	max. 4	max. 6
u. h. f. band		max. 4		max. 5

A.G.C. range

v. h. f. band	min. 40 dB
u. h. f. band	min. 30 dB

R.F. curves

bandwidth, v. h. f. band	typ. 8 to 15 MHz
u. h. f. band	typ. 15 to 25 MHz
tilt, v. h. f. band	max. 3 dB
u. h. f. band, channels 21 to 60	max. 3 dB
channels 61 to 69	max. 4 dB

Power gain (see also MEASURING
METHOD OF POWER GAIN)

v. h. f. band	min. 24 dB
channel 4	typ. 28 dB
channel 13	typ. 27 dB
u. h. f. band	min. 25 dB
channel 21	typ. 32 dB
channel 31	typ. 29 dB
channel 69	typ. 33 dB

Noise figure

v. h. f. band	max. 9 dB
channel 9	typ. 6,5 dB
u. h. f. band	max. 12 dB
channel 21	typ. 8,0 dB
channel 51	typ. 9,5 dB
channel 69	typ. 10,5 dB

1) Best value of V.S.W.R. between picture carrier and sound carrier.

2) Worst value of V.S.W.R. between picture carrier and sound carrier.

I. F. rejection			
v. h. f. band		min. 60 dB	
u. h. f. band		min. 60 dB	
Image rejection			
v. h. f. band		min. 60 dB	
u. h. f. band		min. 40 dB	
Signal handling (see also Figs. 10 and 11)			
Minimum input signal (e. m. f.) producing cross-modulation (1%) at nominal gain, in channel			
(wanted signal: picture carrier frequency,			
interfering signal: sound carrier frequency), v. h. f. band	typ.	4 mV	} 1)
u. h. f. band	typ.	5 to 10 mV	
in band			
(wanted signal: signal carrier frequency of channel N,			
interfering signal: picture carrier of channel N-2 (v. h. f.), N-5 (u. h. f.)			
v. h. f. band	typ.	10 to 50 mV	} 1)
u. h. f. band	typ.	15 to 50 mV	
Minimum input signal (e. m. f.) producing overloading, at nominal gain at maximum a. g. c.			
	typ.	10 mV	} 2)
	typ.	>200 mV	
Minimum input signal (e. m. f.) at nominal gain producing a shift of the oscillator frequency of 10 kHz, v. h. f. band			
u. h. f. band	typ.	>25 mV	} 3)
	typ.	10 to 20 mV	
Detuning of the i. f. output circuit as a result of band switching and tuning with respect of channel 7		max. 400 kHz	

¹⁾ This e. m. f. (open voltage) is referred to an impedance of 75 Ω.
1% cross-modulation means that 1% of the modulation depth of the interfering signal is transferred to the wanted signal.

²⁾ This e. m. f. (open voltage) is referred to an impedance of 75 Ω.
Criterion of overloading: 30% compression of the synchronization pulses of a standard television signal or a noticeable deterioration of the picture quality.

³⁾ This e. m. f. (open voltage) is referred to an impedance of 75 Ω.

Shift of oscillator frequency

at a change of the supply voltage of 10%

v. h. f. band

max. 300 kHz

u. h. f. band

max. 600 kHz

during warm-up time (measured between 5 s
and 15 min after switching on)

v. h. f. band

max. 100 kHz

u. h. f. band

max. 250 kHz

at a gain reduction of 30 dB

max. 100 kHz

Drift of oscillator frequency

at a change of the ambient temperature
from 25 to 40 °C

v. h. f. band

max. 400 kHz

u. h. f. band

max. 500 kHz

Oscillator radiation

The tuner is in conformity with the radiation requirements of C. I. S. P. R. Recommendation No. 24/3, provided the following conditions are fulfilled:

- A low-pass filter (Fig. 9) with a cut-off frequency of about 300 MHz has to be inserted between the v. h. f. aerial terminal of the tuner and the aerial terminal of the receiver. Television receivers with a common v. h. f. /u. h. f. connector in combination with a low-pass/high-pass splitter ¹⁾ may not need this additional filter.

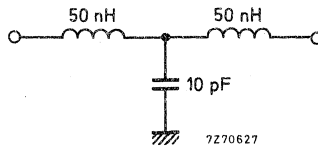

Fig. 9

- No connections must be made to the terminals 7, 9 and 11.
- Earthing of the tuner and connections to the i. f. amplifier have to be made in such a way, that additional radiation is prevented.

Microphonics

If the tuner is installed in a professional manner, there will be no microphonics.

¹⁾ E. g. coaxial aerial input assembly 3122 127 10450.

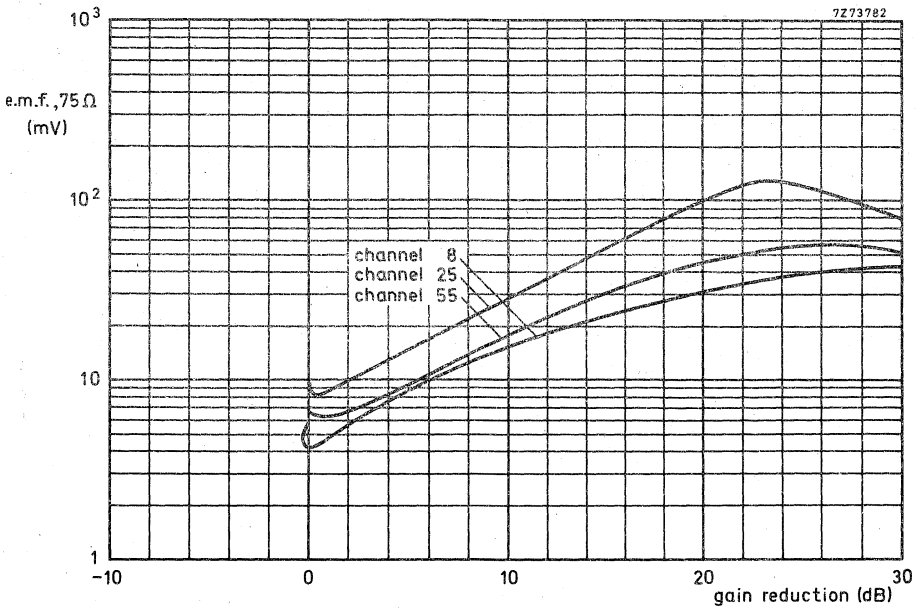

Fig. 10. Cross-modulation, in channel.

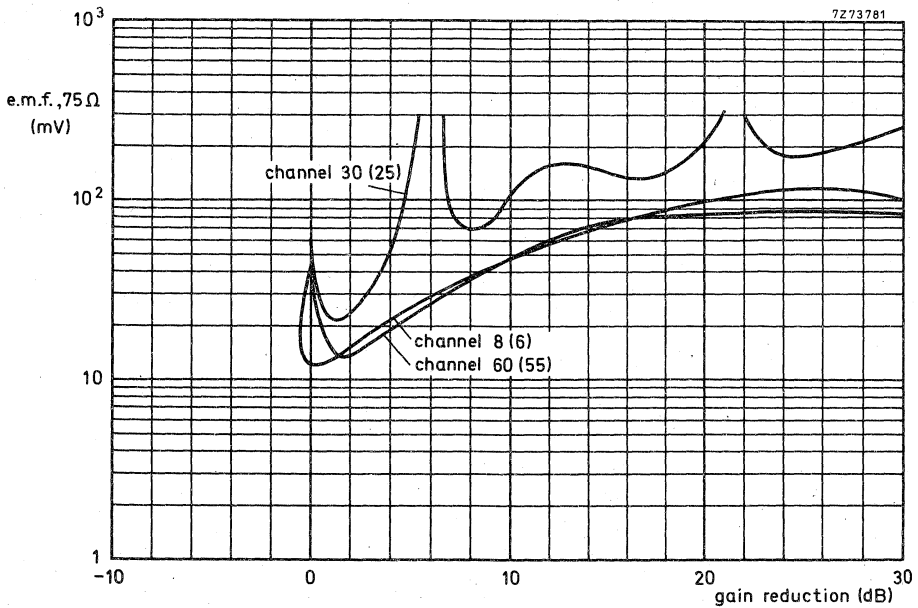

Fig. 11. Cross-modulation, in band; the interfering channels are given between brackets.

APPLICATION INFORMATION

Connection of the tuner

For connection of the tuner the terminal location, Fig. 2, should be consulted. If the tuner is used in receivers the chassis of which is connected to the mains, isolating capacitors according to the safety rules have to be inserted in the aerial leads. Three ways of connecting, depending on the number of switches available, are given below.

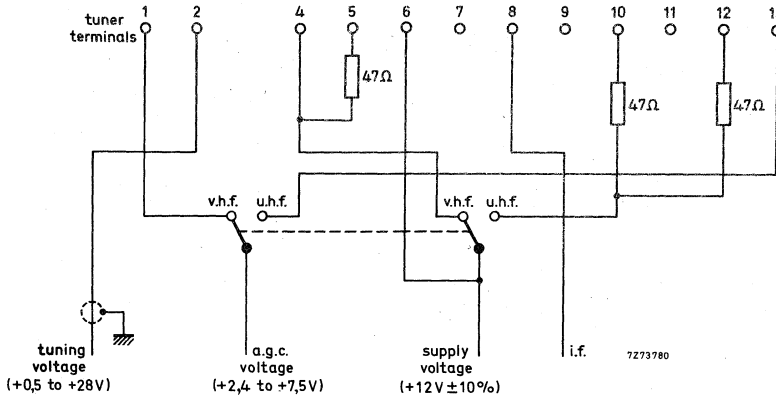

Fig. 12. Connection diagram with two switches.

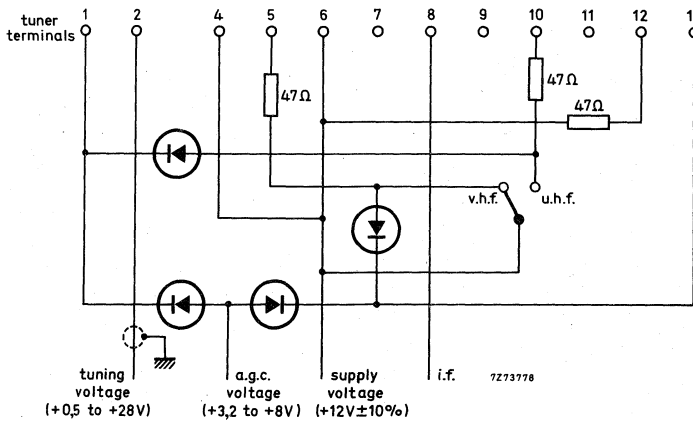

Fig. 13. Connection diagram with one switch.

All diodes: BAX13, BA217 or comparable silicon diodes.

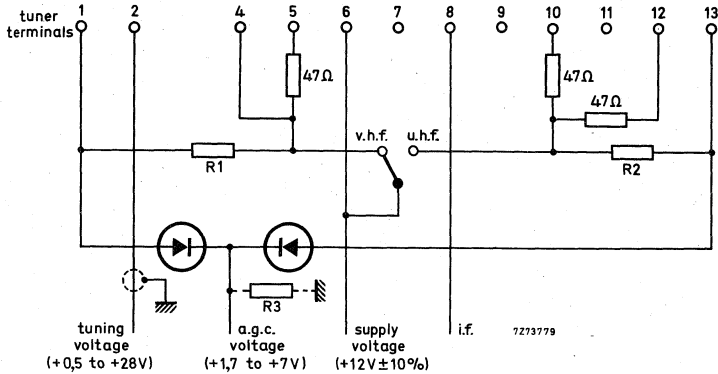

Fig. 14. Connection diagram with one switch.

All diodes: BAX13, BA217 or comparable silicon diodes.

The values of R_1 , R_2 and R_3 depend on a.g.c. circuit.

Alignment of the i. f. circuit

The tuner is provided with an i. f. injection point at the collector of the mixer for aligning the i. f. circuit together with the i. f. amplifier of the television receiver (for the position of the i. f. injection point see Fig. 2).

The tuning should be done with the v. h. f. band tuned. The tuning voltage should be 15 to 20 V.

If this injection method cannot be employed in the television receiver (e.g. because the injection point is not accessible or there is not enough i. f. signal available), the i. f. signal can be fed to test point 3 (terminal 11) via a capacitor of 0,82 to 1 pF. The tuner must be switched to the u. h. f. position; the tuning voltage should be approx. 10 V.

This injection method requires approx. 14 dB less signal than the first method.

No permanent connection must be made to test point 3, otherwise the tuner may exceed the oscillator radiation limits.

MEASURING METHOD OF POWER GAIN

The i. f. output of the tuner should be terminated with the circuit given below.
The terminals 7, 9 and 11 should be not connected.

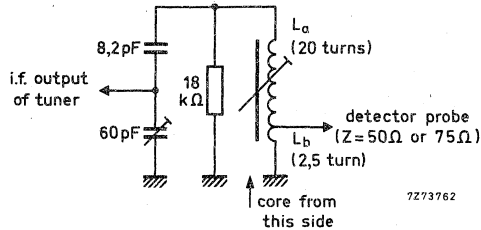

Fig. 15

Switch the tuner to the v. h. f. band; the tuning voltage should be 15 to 20 V.
Feed an i. f. sweep signal (500 to 1000 mV) to the i. f. injection point.
Adjust the trimmer (Fig. 15), tunable coil (L_a/L_b), i. f. output coil of the tuner L519 (Fig. 1) and the coupling between L_a and L_b to get the resonant curve as given below.

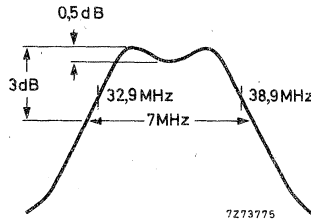

Fig. 16

Then display the r. f. + i. f. curve of the tuner at 190 MHz (picture carrier frequency) and make small corrections in the alignment of the i. f. coils (L_a/L_b and L519), if necessary, to get the markers 38,9 MHz and 32,9 MHz symmetrically on the slopes of the curve, and the peaks at equal amplitude.

Because the output impedance of the dummy circuit is 50 to 75 Ω , the power gain can be measured in the conventional manner by inserting tuner and dummy circuit between a 75 Ω source and a 75 Ω detector (or between a 50 Ω source and matching pad 50/75 Ω and a 50 Ω detector).

ACCESSORIES

Aerial input transformer ELC1094, v. h. f. , catalogue number : 2422 542 10941;
aerial input transformer ELC2092, u. h. f. , catalogue number : 2422 542 12921;
coaxial aerial input assembly, catalogue number 3122 127 10450.

V.H.F. TELEVISION TUNER

with diode tuning

QUICK REFERENCE DATA

Systems	C.C.I.R. systems M and N (R.T.M.A.)
Channels	A2 to A6 (low v.h.f. band) A7 to A13 (high v.h.f. band)
Intermediate frequencies	
picture	45,75 MHz
sound	41,25 MHz

APPLICATION

Designed to cover the v.h.f. channels of C.C.I.R. systems M and N (R.T.M.A.).

Thanks to its good signal-handling properties, the tuner is especially suited for strong signal areas.



DESCRIPTION

The ELC3082 is a v.h.f. tuner with electronic tuning and band switching, covering the low v.h.f. band (frequency range 54 to 88 MHz) and the high v.h.f. band (frequency range 174 to 216 MHz).

Mechanically, the tuner is built on a low-loss printed-wiring board, carrying all components, in a metal housing made of a rectangular frame and front and rear covers (see Fig. 2). The aerial connection is on one of the frame sides, all other connections (supply voltages, a.g.c. voltage, tuning and switching voltages) are made via terminals in the under side. The mounting method is shown in Figs 3 and 4.

Electrically, the tuner consists of v.h.f. and i.f. parts. The aerial signal is fed to the input filters, providing i.f. rejection and band selection. The filters are followed by a P-I-N diode attenuator, equipped with two diodes BA379. The output of the attenuator is connected to the emitter of the input transistor BF480, operating as r.f. amplifier in grounded base configuration. The same transistor also delivers the current drive for the P-I-N diode attenuator, controlled by an a.g.c. voltage fed to the transistor base. The combination of the diode attenuator with this high current transistor (I_E at normal gain about 10 mA) has excellent signal-handling properties within the whole a.g.c. range.



The collector load of the input transistor is formed by a double tuned circuit, transferring the signal to the emitter of the mixer transistor BF324. Good signal-handling properties of this stage are achieved by high oscillator injection. The oscillator is equipped with a transistor BF324. In the low v.h.f. position, self-detection of the oscillator signal is used to back-bias the five switching diodes BA482/483/484, required for band switching between low and high v.h.f. channels. Three capacitance diodes BB809 provide tuning of the r.f. circuits. The collector of the mixer transistor is connected to a single tuned i.f. resonant circuit (about 20 MHz bandwidth), the output of which is fed to the i.f. output stage, equipped with another transistor BF324 in grounded base configuration. This stage has also been designed especially for good signal-handling properties. The collector load of the i.f. output transistor is formed by a single tuned i.f. circuit, at the low end of which the i.f. signal is capacitively coupled out of the tuner.

The tuner can be used in combination with a u.h.f. tuner. In this case the u.h.f. i.f. signal is fed to the emitter of the i.f. output transistor, which acts as i.f. amplifier for u.h.f. as well as for v.h.f.

The u.h.f. i.f. input terminal can be used as an i.f. injection point for aligning the i.f. output circuit together with the i.f. amplifier of the television receiver. For the same purpose a separate i.f. injection point has been provided at the collector of the mixer.

The tuner requires transistor supply voltages of +12 V, a switching voltage of +12 V, a.g.c. voltages, variable from +5 V (normal operating point) to about +2,5 V (maximum a.g.c.) and a tuning voltage, variable from +0,5 V to +28 V.

The aerial input of the tuner is asymmetrical. For use in symmetrical aerial systems, aerial transformers (baluns) are available (see ACCESSORY).

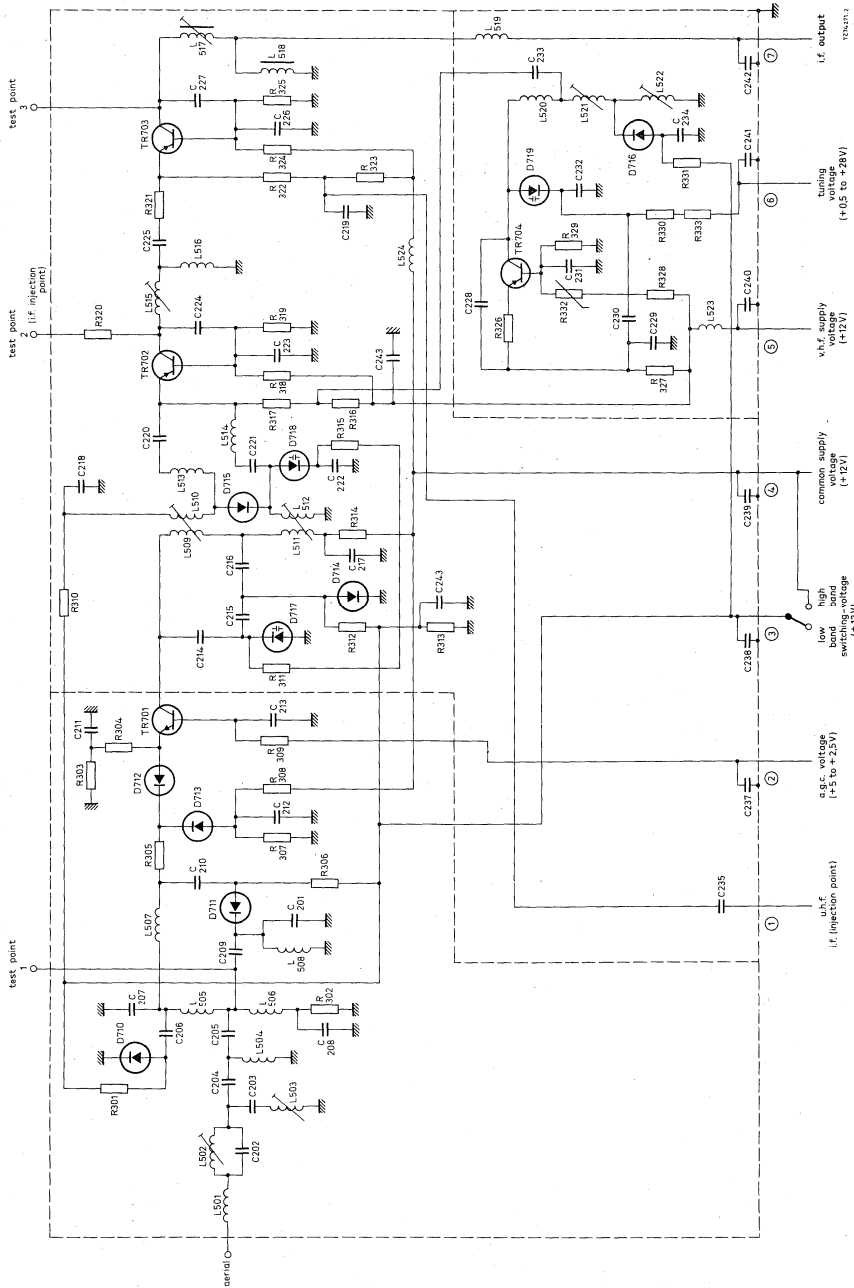

Fig. 1.

MECHANICAL DATA

Dimensions in mm

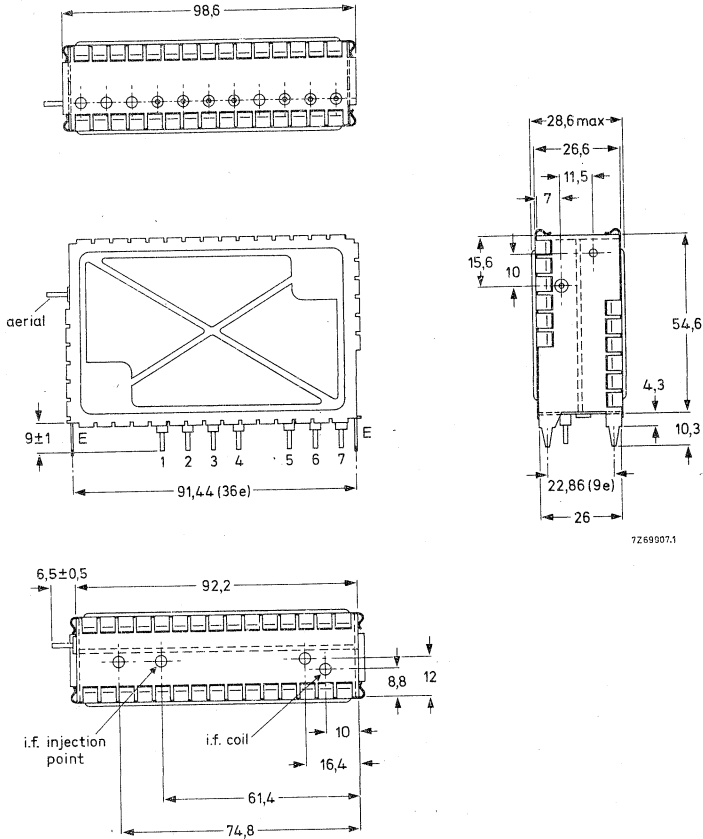

Fig. 2.

- Terminal 1 = u.h.f. i.f. input
- 2 = a.g.c. voltage, +5 to +2,5 V
- 3 = switching voltage, +12 V
- 4 = common supply voltage, +12 V
- 5 = v.h.f. supply voltage, +12 V
- 6 = tuning voltage, +0,5 to +28 V
- 7 = i.f. output
- E = earth

Mounting

The tuner may be mounted by soldering it on to a printed-wiring board, using the piercing diagram shown in Fig. 3. (The tuner may also be mounted by means of a bracket. Information will be supplied upon request.)

The tuner may be mounted anywhere in the receiver and there are no restrictions on orientation.

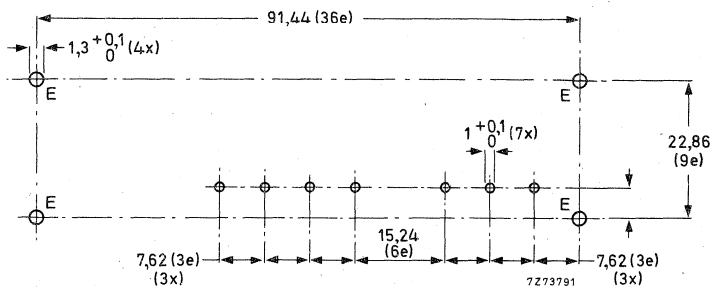

Fig. 3 Piercing diagram viewed from solder side of board: e = 2,54 mm (0,1 in).

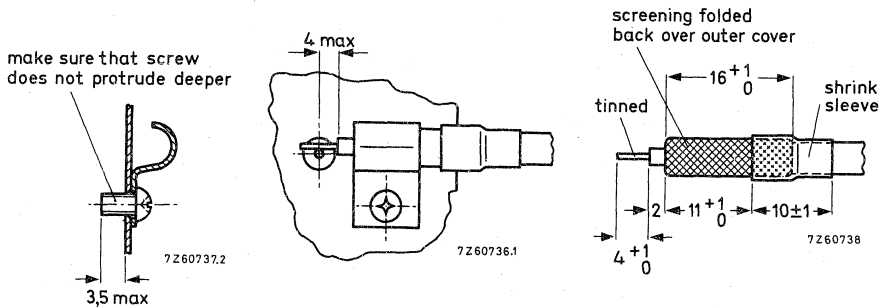

Fig. 4 Recommended fixing method of the aerial cable. Use a self-tapping screw.

ELECTRICAL DATA

Unless otherwise specified all electrical values apply at an ambient temperature of 25 ± 5 °C and a supply voltage of $12 \pm 0,3$ V.

Semiconductors

	P-I-N attenuator	2 x BA379
	r.f. amplifier	BF480
	mixer	BF324
	oscillator	BF324
→	tuning diodes	3 x BB809
→	switching diodes	5 x BA482/483/484
	i.f. amplifier	BF324

Ambient temperature range

operating	+5 to +55 °C
storage	-25 to +85 °C

Supply voltage

+12 V \pm 10%

Current drawn from +12 V supply at nominal gain

low band	46,5 mA \pm 10%
high band	63,5 mA \pm 10%

Notes — At 40 dB gain reduction the currents decrease about 5 mA.

- The supply voltage at terminal 4 should be carefully filtered to avoid hum modulation in one of the P-I-N diodes when the attenuator is biased to higher attenuation ratios. Under most unfavourable conditions a ripple voltage of 3 mV (p-p) may produce a disturbance which is just visible.

A.G.C. voltage (Figs 5 and 6)

low band, at nominal gain	+5 \pm 0,2 V *
at 40 dB gain reduction	+3,3 V (typical)
high band, at nominal gain	+5 \pm 0,2 V *
at 40 dB gain reduction	+3,3 V (typical)

A.G.C. current

at nominal gain	max. 1 mA
with a.g.c.	max. 1 mA

Tuning voltage range (Figs 7 and 8)

Current drawn from 28 V tuning voltage supply	+0,5 to +28 V
	max. 0,5 μ A

Note — The source impedance of the tuning voltage, offered to terminal 6, must be max. 100 k Ω at tuning voltages below 5 V.

Switching voltage

low band	open circuit
high band	+12 V \pm 10%

Note — In the low band position the tuner produces a negative voltage (1 to 5 V) at terminal 3; this terminal must not be loaded with an external resistance below 50 M Ω .

* This value may be increased to 5,5 V if a certain deterioration of signal handling is accepted. At voltages above 5,5 V the cross-modulation in band may deteriorate rapidly.

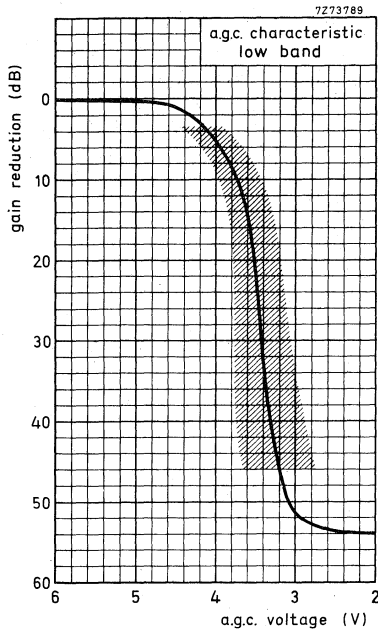

Fig. 5.

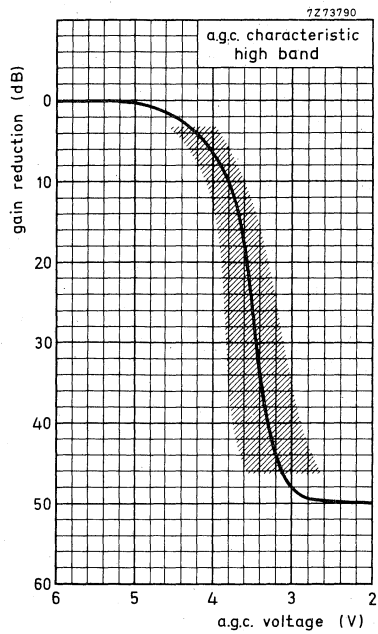

Fig. 6.

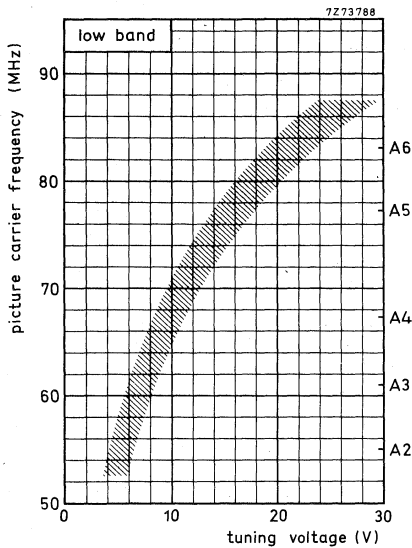

Fig. 7.

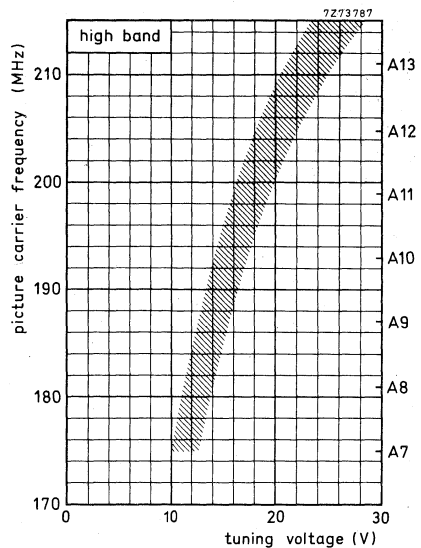

Fig. 8.

Frequency ranges
low band

high band

Intermediate frequencies

picture
sound

Input impedance
asymmetrical
symmetrical *

V.S.W.R. (between picture carrier
and sound carrier)

low band
high band

A.G.C. range

low band
high band

R.F. curves

bandwidth, low band
high band

tilt, low band
high band

Power gain (see also MEASURING METHOD OF POWER GAIN)

low band
channel A2
channel A6
high band
channel A7
channel A13

Noise figure

low band
high band

I.F. rejection

low band, channel A2
channel A3
channels A4 to A6
high band

channel A2 (picture carrier 55,25 MHz)
to channel A6 (picture carrier 83,25 MHz).
Margin at the extreme channels: min. 2 MHz.
channel A7 (picture carrier 175,25 MHz)
to channel A13 (picture carrier 211,25 MHz).
Margin at the extreme channels: min. 3 MHz.

45,75 MHz
41,25 MHz

75 Ω
300 Ω (see ACCESSORY)

v.s.w.r. at nom. gain	max. v.s.w.r. during gain control
max. 3,5 max. 4	max. 3,5 max. 4

min. 40 dB (typ. 54 dB)
min. 40 dB (typ. 50 dB)

typ. 7 to 10 MHz
typ. 8 to 10 MHz
max. 3 dB
max. 3 dB

min. 24 dB
typ. 27 dB
typ. 29 dB
min. 25 dB
typ. 28 dB
typ. 31 dB

max. 9,5 dB (typ. 7 dB)
max. 9,5 dB (typ. 7,5 dB)

min. 54 dB
min. 57 dB
min. 60 dB
min. 60 dB

* With aerial input transformer ELC1094.

Image rejection		
low band	min. 56 dB	
high band	min. 50 dB	
Signal handling		
Minimum input signal (e.m.f.) producing cross-modulation (1%) in channel	max. gain	with a.g.c.
wanted signal: picture carrier frequency, interfering signal: sound carrier frequency in band	typ. 20 mV	typ. > 500 mV
wanted signal: picture carrier frequency of channel N, interfering signal: picture carrier of channel $N \pm 2$	typ. 100 mV	typ. > 500 mV
interfering signal: picture carrier of channel $\geq N \pm 3$	typ. 250 mV	typ. > 500 mV
Minimum input signal (e.m.f.) producing overloading, at nominal gain	typ. 50 mV	} **
at maximum a.g.c.	typ. > 500 mV	
Minimum input signal (e.m.f.) at nominal gain producing a shift of the oscillator frequency of 10 kHz,		
low band	typ. 50 mV	} ▲
high band	typ. 30 mV	
Detuning of the i.f. output circuit as a result of band switching and tuning	max. 150 kHz	
Shift of oscillator frequency at a change of the supply voltage of 5%		
low band	max. 300 kHz	
high band	max. 300 kHz	
during warm-up time (measured between 5 s and 15 min after switching on)		
low band	max. 150 kHz	
high band	max. 150 kHz	



* This e.m.f. (open voltage) is referred to an impedance of 75 Ω. 1% cross-modulation means that 1% of the modulation depth of the interfering signal is transferred to the wanted signal.

** This e.m.f. (open voltage) is referred to an impedance of 75 Ω. Criterion of overloading: 30% compression of the synchronization pulses of a standard television signal or a noticeable deterioration of the picture quality.

▲ This e.m.f. (open voltage) is referred to an impedance of 75 Ω.

Drift of oscillator frequency

at a change of the ambient temperature from 25 to 50 °C
25 to 50 °C

low band

max. 500 kHz

high band

max. 500 kHz

Oscillator radiation

The tuner is in conformity with the radiation requirements of C.I.S.P.R. Recommendation No. 24/2 and the corresponding F.C.C. rules , provided the tuner is installed in a professional manner.

Microphonics

If the tuner is installed in a professional manner, there will be no microphonics.

→ Surge protection

Protection against voltages

max. 5 kV

Note: Three discharges of a 470 pF capacitor into the aerial terminal.



ALIGNMENT OF THE I.F. CIRCUIT

For i.f. injection the u.h.f. i.f. input (terminal 1) or the i.f. injection point at the collector of the mixer transistor (at the top of the tuner, Fig. 2) can be used. The aligning can be done with any channel tuned. A probe as shown in Fig. 9 should be used.

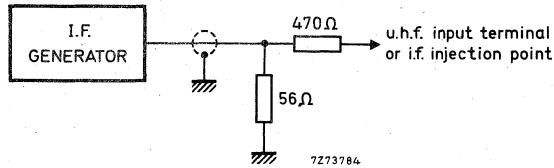

Fig. 9.

The signal attenuation between the i.f. generator and the i.f. output of the tuner is about 4 dB when injection is done via the injection point, and about 8,5 dB in the case of injection via the u.h.f. i.f. input. The i.f. output circuit is detuned about +300 kHz* or -150 kHz* when injection is done via the injection point or via the u.h.f. i.f. input respectively.

MEASURING METHOD OF POWER GAIN

The i.f. output of the tuner should be terminated with the RC-circuit given in Fig. 10.

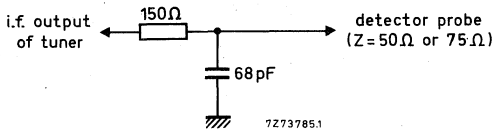

Fig. 10.

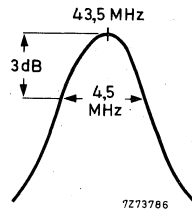

Fig. 11.

The RC-circuit roughly matches the i.f. output impedance to 75 Ω at the resonant frequency of the i.f. output circuit, which should be tuned to 43,5 MHz. The bandwidth should be approx. 4,5 MHz. Because the input and output impedances of the tuner are now 75 Ω, the power gain can be measured in the conventional manner by inserting tuner and RC-circuit between a 75 Ω source and a 75 Ω detector (or between a 50 Ω source and matching pad 50/75 Ω and a 50 Ω detector).

ACCESSORY

Aerial input transformer ELC1094, v.h.f., catalogue number: 2422 542 10941.

* Reference: normal operation with r.f. signal via aerial input.

U.H.F. TELEVISION TUNER

QUICK REFERENCE DATA

System	C.C.I.R. system M (R.T.M.A.)
Channels	A14 to A78
Intermediate frequencies	
picture	45,75 MHz
sound	41,25 MHz

APPLICATION

This tuner is designed to cover the u.h.f. channels A14 to A78 of C.C.I.R. system M (R.T.M.A.). In combination with a suitable v.h.f. tuner, e.g. ELC3082 it can be used in v.h.f./u.h.f. receivers. Small adaptations in the receiver may be necessary, depending on the receiver type.



DESCRIPTION

The U323 is a u.h.f. tuner with electronic tuning, covering the u.h.f. band from 470 to 860 MHz.

Mechanically, the tuner is built on a printed-wiring board, carrying all components, in a metal housing made of a rectangular frame and front and rear cover (see Fig. 2a). All connections (aerial, supply voltages, a.g.c. voltage, tuning voltage, i.f. injection, i.f. output) are made via terminals on the underside. The mounting method is shown in Fig. 3.

Electrically, the tuner consists of an input circuit with a high-pass characteristic, followed by a P-I-N diode attenuator (1 diode BA379) and the input transistor BF480 in grounded-base configuration. This transistor operates at an emitter current of about 8 to 10 mA, featuring good noise figures and good signal handling properties. It also supplies the current drive for the P-I-N diode attenuator, controlled by an a.g.c. voltage fed to the transistor's base. This combination has good signal handling properties throughout the a.g.c. range. The collector load of the input transistor is formed by a double tuned circuit, transferring the signal to the mixer diode BA280 (or MBD102). The selectivity of this circuit at the image frequency has been improved by special means. The mixer diode is driven by an oscillator, equipped with a transistor BF480.

The i.f. signal, originated in the mixer, is amplified by a transistor BF324 in grounded-base configuration. The combination of the Schottky-barrier diode BA280 (or MBD102) and the i.f. transistor BF324 also features good noise figures and good signal handling properties. Three capacitance diodes BB105B tune the double tuned circuit and the oscillator.

The i.f. output circuit of the tuner is a single tuned one, at the low end of which the i.f. signal is coupled out of the tuner. A d.c. path to earth for the collector current of the i.f. transistor BF324 has to be provided outside the tuner, preferably by a choke of about $5 \mu\text{H}$. Damping of the i.f. output circuit and matching of the i.f. output to the i.f. circuit of the receiver can be achieved by connecting a series resistance and a parallel capacitance outside the tuner.

An i.f. injection point has been provided at the collector of the i.f. transistor, connected to terminal 7.

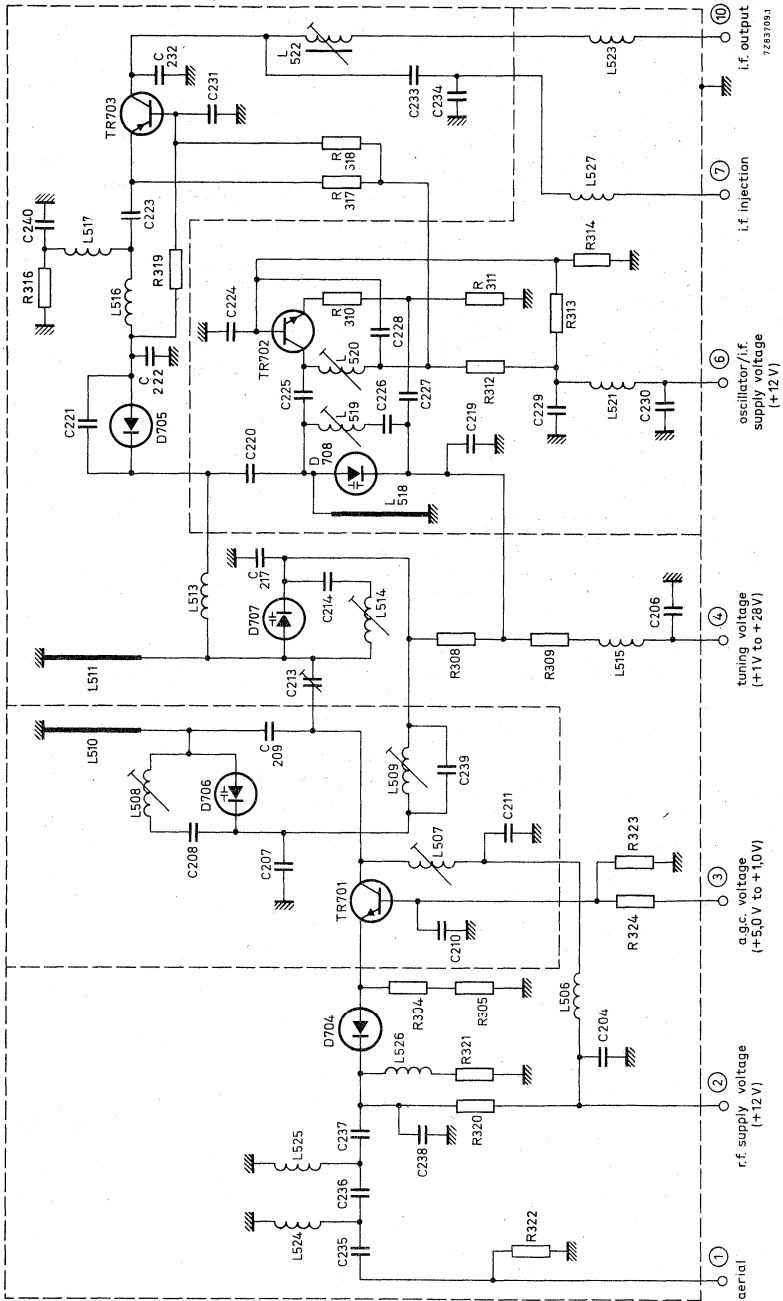

Fig. 1.

MECHANICAL DATA

Dimensions in mm

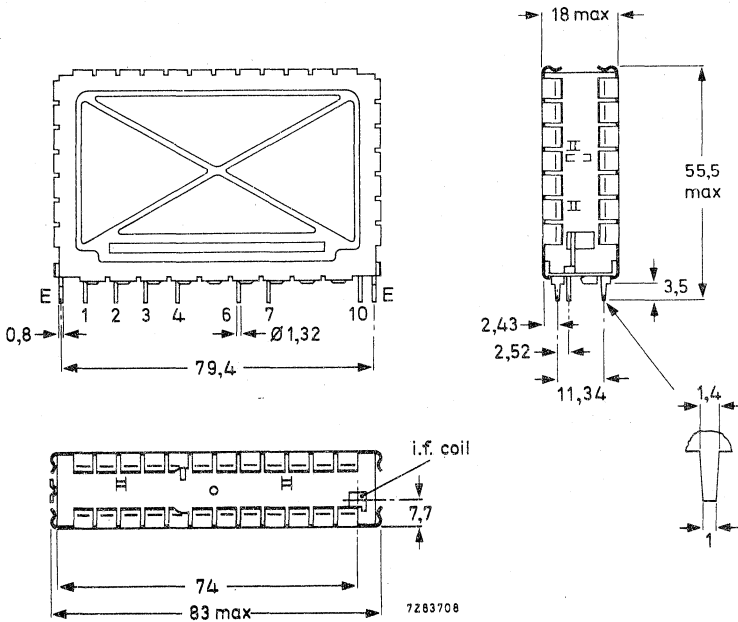

Fig. 2a Terminal 1 = aerial
 2 = r.f. supply voltage, + 12 V
 3 = a.g.c. voltage, + 5,0 to + 1,0 V
 4 = tuning voltage, + 1 to + 28 V
 6 = oscillator/i.f. supply voltage, + 12 V
 7 = i.f. injection point
 10 = i.f. output

Note: When the tuner is operated together with a v.h.f. tuner, only the supply voltage at terminal 6 should be switched off during v.h.f. operation.

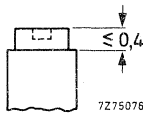

Fig. 2b I.F. output coil.
 Torque for alignment: 2 to 15 mNm
 Press-through force: ≥ 10 N

Mass approx. 75 g

Mounting

The tuner may be mounted by soldering it on to a printed-wiring board, using the piercing diagram shown in Fig. 3. (The tuner may also be mounted by means of a socket. Information will be supplied upon request.)

It is recommended that the tuner be installed in the cool part of the receiver cabinet and not exposed to the vibrations of the loudspeaker. There are no restrictions on orientation.

The solderability of the terminals and mounting tabs is according to IEC 68-2, test Ta ($230 \pm 10 \text{ }^\circ\text{C}$, $2 \pm 0,5 \text{ s}$). The resistance to soldering heat is according to IEC 68-2, test Tb ($260 \pm 5 \text{ }^\circ\text{C}$, $10 \pm 1 \text{ s}$).

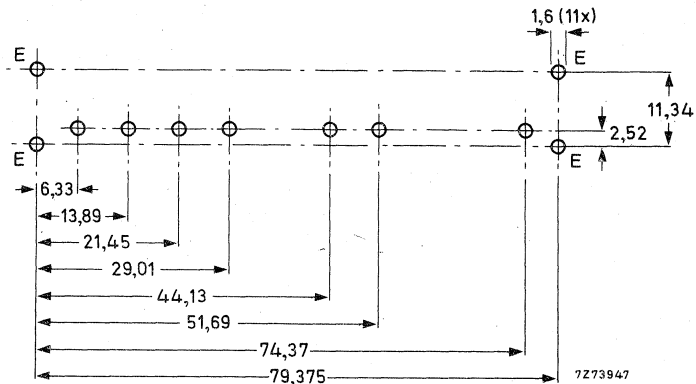

Fig. 3 Piercing diagram viewed from solder side of board.

ELECTRICAL DATA

Unless otherwise specified all electrical values apply at an ambient temperature of 25 ± 5 °C, a relative humidity of $60 \pm 15\%$, a supply voltage of $12 \pm 0,3$ V and an a.g.c. voltage of $5,0 \pm 0,2$ V.

Within the given tolerance range of supply voltage and a.g.c. voltage only insignificant deviations from the specified values can be expected. Under the extreme conditions of temperature and humidity as given below, the tuner will function normally, but some specified limits may be exceeded.

General**Semiconductors**

P-I-N diode	BA379
r.f. amplifier	BF480
mixer	BA280 (or MBD102)
oscillator	BF480
tuning diodes	3 x BB105B
i.f. amplifier	BF324

Ambient temperature range

operating	+ 5 to + 55 °C
storage	-25 to + 85 °C

Relative humidity

max. 95%

Voltages and currents

Supply voltage + 12 V \pm 10%

Note: The supply voltage at terminal 2 (input stage) should be filtered to avoid hum modulation in the P-I-N diode when the attenuator is biased to higher attenuation ratios.

Current drawn from + 12 V supply

r.f. amplifier, at nominal gain	typ. 13 mA
r.f. amplifier, at 30 dB gain reduction	typ. 4,5 mA
oscillator/i.f. amplifier	max. 16 mA

A.G.C. voltage (Fig. 4), at nominal gain + 5,0 \pm 0,2 V

A.G.C. voltage, at 30 dB gain reduction min. + 0,8 V

A.G.C. current (Fig. 4)

during gain control (0 to 30 dB)	max. + 1 mA
at nominal gain	typ. + 0,85 mA
at 30 dB gain reduction	typ. + 0,2 mA

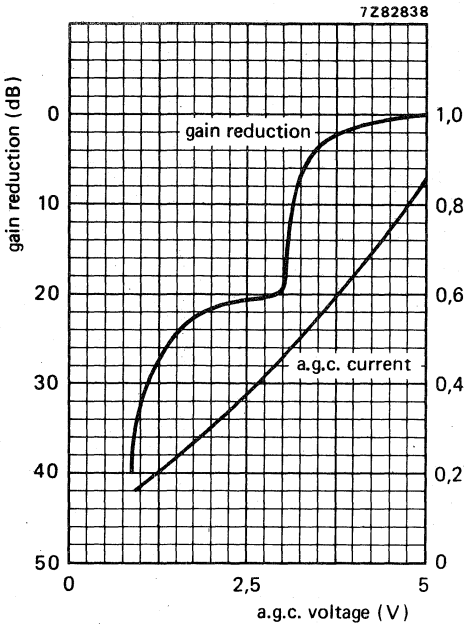

Fig. 4.

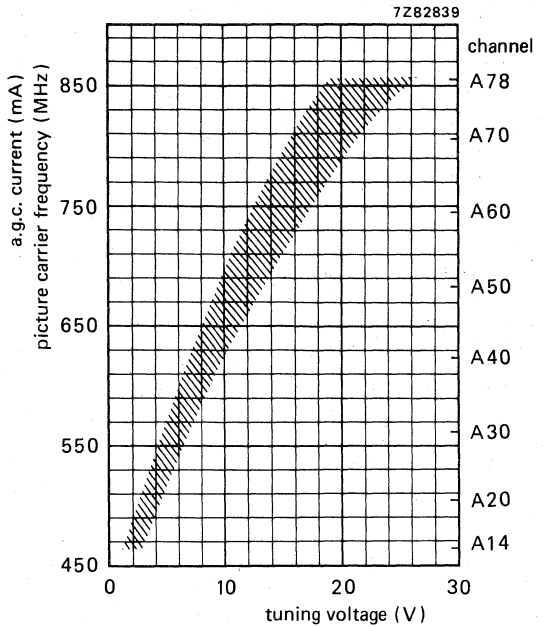

Fig. 5.

Tuning voltage range (Fig. 5)

Current drawn from +28 V tuning voltage supply

at $T_{amb} = 25^{\circ}C$

at $T_{amb} = 55^{\circ}C$

Slope of tuning characteristic

at 471 MHz

at 855 MHz

+1 to +28 V

max. 0,15 μA

max. 0,6 μA

min. 4 MHz/V

typ. 24 MHz/V

typ. 8 MHz/V

Note: The source impedance of the tuning voltage offered to terminal 4 must be maximum 47 k Ω at tuning voltages below 3 V.

Frequencies

Frequency range

channel A14 (picture carrier 471,25 MHz)
to channel A78 (picture carrier 855,25 MHz).
Margin at the extreme channels: min. 3 MHz.

Intermediate frequencies

picture
sound

45,75 MHz

41,25 MHz

The oscillator frequency is higher than the
aerial signal frequency.

Wanted signal characteristics

Input impedance

asymmetrical

75 Ω V.S.W.R. and reflection coefficient at picture
carrier frequency, at nominal gain

v.s.w.r.

max. 5

reflection coefficient

max. 66%

R.F. curves, bandwidth

typ. 18 MHz

R.F. curves, tilt

on any channel the amplitude difference
between the top of the r.f. resonant curve and
the picture carrier marker, the sound carrier
marker, or any frequency between them will
not exceed 3 dB at nominal gain, and 4 dB in
the a.g.c. range between nominal gain and
20 dB gain reduction.

A.G.C. range

min. 30 dB

Power gain (see also Measuring method of power gain)

min. 18 dB

channel A14

typ. 24 dB

channel A40

typ. 21 dB

channel A78

typ. 25 dB

Gain difference between any two channels

typ. 4 dB

Noise figure

max. 10 dB

channel A14

typ. 7,5 dB

channel A40

typ. 8 dB

channel A78

typ. 8,5 dB

Overloading

Input signal producing 1 dB gain
compression at nominal gain

typ. 92 dB (μ V) into 75 Ω

Input signal producing either a detuning
of the oscillator of +300 kHz or -1000 kHz
or stopping of the oscillations at nominal gain

typ. 100 dB (μ V) into 75 Ω **Unwanted signal characteristics**

Image rejection (measured at picture carrier frequency)

channels A14 to A63

min. 46 dB; typ. 57 dB

I.F. rejection (measured at picture carrier and
colour sub-carrier frequency)

min. 60 dB

N + 4 rejection

Interference signal of picture carrier of channel N + 4, which produces a 43,5 MHz i.f. signal that is 46 dB below the picture carrier of wanted channel N (input level 60 dB (μ V), tuner operating at maximal gain) typ. 76 dB (μ V)

N \pm 7 rejection

Interference signal for an interference ratio of 46 dB referred to wanted picture carrier (wanted signal 60 dB (μ V); tuner operating at nominal gain) typ. 80 dB (μ V) into 75 Ω

Cross modulation

Input signal producing 1% cross modulation, i.e. 1% of the modulation depth of the interfering signal is transferred to the wanted signal.

In channel cross modulation (wanted signal): picture carrier frequency; interfering signal: sound carrier frequency)

at nominal (wanted input level 60 dB (μ V)) typ. 80 dB (μ V) into 75 Ω

at 26 dB gain reduction (wanted input level 86 dB (μ V)) typ. 100 dB (μ V) into 75 Ω

In band cross modulation (wanted signal: picture carrier of channel N; interfering signal: picture carrier of channel N + 7)

at nominal gain (wanted input level 60 (μ V)) typ. 90 dB (μ V) into 75 Ω

at 26 dB gain reduction (wanted input level 86 dB (μ V)) typ. 100 dB (μ V) into 75 Ω

Out of band cross modulation, at nominal gain

v.h.f. I min. 110 dB (μ V) into 75 Ω

v.h.f. III min. 110 dB (μ V) into 75 Ω

Oscillator characteristics**Pulling**

Input signal of tuned frequency producing a shift of the oscillator frequency of 10 kHz, at nominal gain typ. 80 dB (μ V) into 75 Ω

Shift of oscillator frequency

at a change of the supply voltage of 5% max. 550 kHz

Drift of oscillator frequency

during warm-up time (after the tuner has been completely out of operation for 15 min, measured between 5 s and 15 min after switching on) max. 250 kHz

during warm-up time (after the input stage is in operation for 15 min, measured between 2 s and 15 min after switching on the oscillator/i.f. stage) max. 250 kHz

at a change of the ambient temperature from +25 to +40 $^{\circ}$ C (measured after 3 cycles from +25 to +55 $^{\circ}$ C)

channels A14 to A66 max. 500 kHz
 channels A67 to A73 max. 650 kHz
 channels A74 to A78 max. 750 kHz

I.F. circuit characteristics

Bandwidth of i.f. output circuit 7,5 \pm 1 MHz

Note: I.F. output of the tuner terminated with the circuit shown in Fig. 6; tuning voltage 15 V.

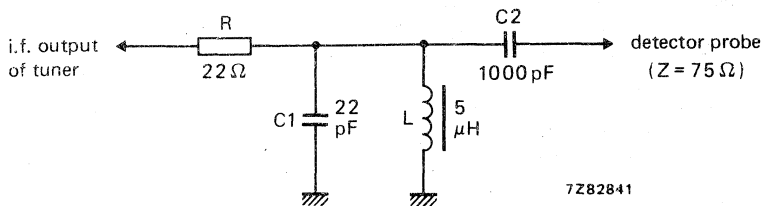

Fig. 6.

Bandwidth variation of i.f. output circuit as a result of r.f. tuning

max. 500 kHz

Note: I.F. output of the tuner terminated with a modified circuit of Fig. 6, i.e. a 100 pF capacitor is connected in parallel with C1 and R is short-circuited; tuning voltage 15 V.

Detuning of the i.f. output circuit as a result of r.f. tuning

max. 500 kHz

Note: I.F. output of the tuner terminated with a modified circuit of Fig. 6, i.e. a 100 pF capacitor is connected in parallel with C1 and R is short-circuited; tuning voltage 15 V.

Minimum tuning range of i.f. output coil

41 to 47 MHz

Note: I.F. output of the tuner terminated with the circuit shown in Fig. 6; tuning voltage 15 V.

Attenuation between i.f. injection point and i.f. output of the tuner

23 ± 3 dB

Miscellaneous

Radio interference

Oscillator radiation and oscillator voltage at the aerial terminal

Within the limits of C.I.S.P.R. 13 (1975).

For the oscillator radiation use is made of the relaxed limit of 3 mV/m (70 dB μ V/m).

Microphonics

Therefore will be no microphones, provided the tuner is installed in a professional manner.

Surge protection

Protection against voltages

max. 8 kV

Note: Three discharges of a 470 pF capacitor into the aerial terminal.

Protection against flashes

max. 30 kV, 400 mWs

Note: A flashover circuit producing flashes with frequencies of 1 to 20 Hz for 30 s is connected to the aerial terminal.

ADDITIONAL INFORMATION

I.F. injection

The tuner is provided with an i.f. injection point at the collector of the i.f. transistor (coupled via a capacitor to terminal 7). The i.f. generator can be connected directly to this point (Fig. 7). The tuner needs normal supply voltages and a tuning voltage of 15 V; the i.f. output should be loaded with the circuit shown in Fig. 6.

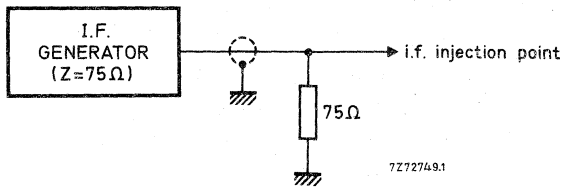

Fig. 7.

Connection of the i.f. amplifier

The tuner needs a d.c. path from the i.f. output terminal (10) to earth, preferably via a choke of approx. $5 \mu\text{H}$ outside the tuner (Fig. 8). For damping the i.f. output circuit and matching the i.f. output impedance of the tuner to the i.f. amplifier, a series resistor and a parallel capacitor as shown in Fig. 8 should be used.

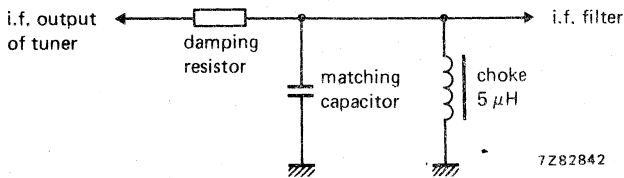

Fig. 8.

Measuring method of power gain

The i.f. output of the tuner should be terminated with the RC-circuit given in Fig. 6.

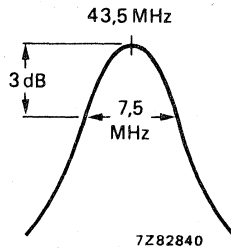

Fig. 9.

The RC-circuit roughly matches the i.f. output impedance to 75Ω at the resonant frequency of the i.f. output circuit, which should be tuned to 43,5 MHz; the bandwidth should be approx. 7,5 MHz (Fig. 9).

Because the input and output impedances of the tuner are now 75Ω , the power gain can be measured in the conventional manner by inserting tuner and RC-circuit between a 75Ω source and a 75Ω detector.

Alignment of the i.f. output coil

The i.f. output coil should be adjusted with a brass tool with a blade as shown in Fig. 10. A suitable tool is available under catalogue number 7122 005 47680.

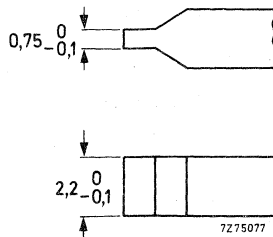

Fig. 10.

ACCESSORIES

Aerial input transformer, catalogue number 3122 127 24330.

U.H.F. TELEVISION TUNERS

QUICK REFERENCE DATA

Systems	C.C.I.R. systems I (United Kingdom), G, H and K	
Channels	E21 to E69	
	<u>systems I and K</u>	<u>systems G and H</u>
Intermediate frequencies		
picture	39,5 MHz	38,9 MHz
sound	33,5 MHz	33,4 MHz

APPLICATION

These tuners are for use in u.h.f. single-standard receivers. In combination with v.h.f. tuner V317 or V334 they can also be used in v.h.f./u.h.f. receivers.

The tuners meet the special requirements of the United Kingdom.

The U341 LO is a special version of the U341; an output voltage sample from the local oscillator is available for driving digital tuning systems. Apart from this the tuners are identical.

The tuners are pin-compatible with tuners U321 and U321LO; the a.g.c. circuit is voltage driven, unlike the U321, where the a.g.c. circuit is current driven.



DESCRIPTION

These are u.h.f. tuners with electronic tuning, covering the u.h.f. band from 470 to 860 MHz. The tuner circuit is built on a printed-wiring board and enclosed in a metal housing comprising a rectangular frame and front and rear covers (see Fig. 2). The shielded aerial connection is on one of the frame sides, all other connections (supply voltages, a.g.c., tuning voltage, i.f. injection, i.f. output) are made via terminals on the underside. The mounting method is shown in Figs 3 and 4.

Tuner U341LO has a coaxial socket on the top of the frame for the oscillator output sample.

Electrically, the tuners consist of an input circuit with a high-pass characteristic and a MOS-FET tetrode BF980. This tetrode operates at a drain current of about 10 mA, and has good noise figures and signal handling properties. It also acts as an a.g.c. device, controlled by an a.g.c. voltage fed to gate 2. This combination has good signal handling properties throughout the a.g.c. range. The drain load of the MOS-FET tetrode is formed by a double tuned circuit which transfers the signal to the mixer diode 1SS99. The selectivity of this circuit at the image frequency has been improved by special means. The mixer diode is driven by an oscillator transistor BF480. At the U341LO the oscillator sample is fed out of the mixer via a small capacitor in series with a resistor.

The i.f. signal, from the mixer, is amplified by a transistor BF324 in grounded-base configuration. The combination of the Schottky-barrier diode 1SS99 and the i.f. transistor BF324 ensures good noise figures and signal handling properties. Three capacitance diodes BB405B tune the double tuned circuit and the oscillator.

The i.f. output circuit is single tuned with output coupling from the low impedance side. A d.c. path to earth for the collector current of the i.f. transistor BF324 must be provided outside the tuner, preferably by a choke of about 5 μ H. Damping of the i.f. output circuit and matching to the i.f. circuit of the receiver can be achieved by connecting a series resistance and a parallel capacitance outside the tuner.

An i.f. injection point is provided at the collector of the i.f. transistor, connected to terminal 7.

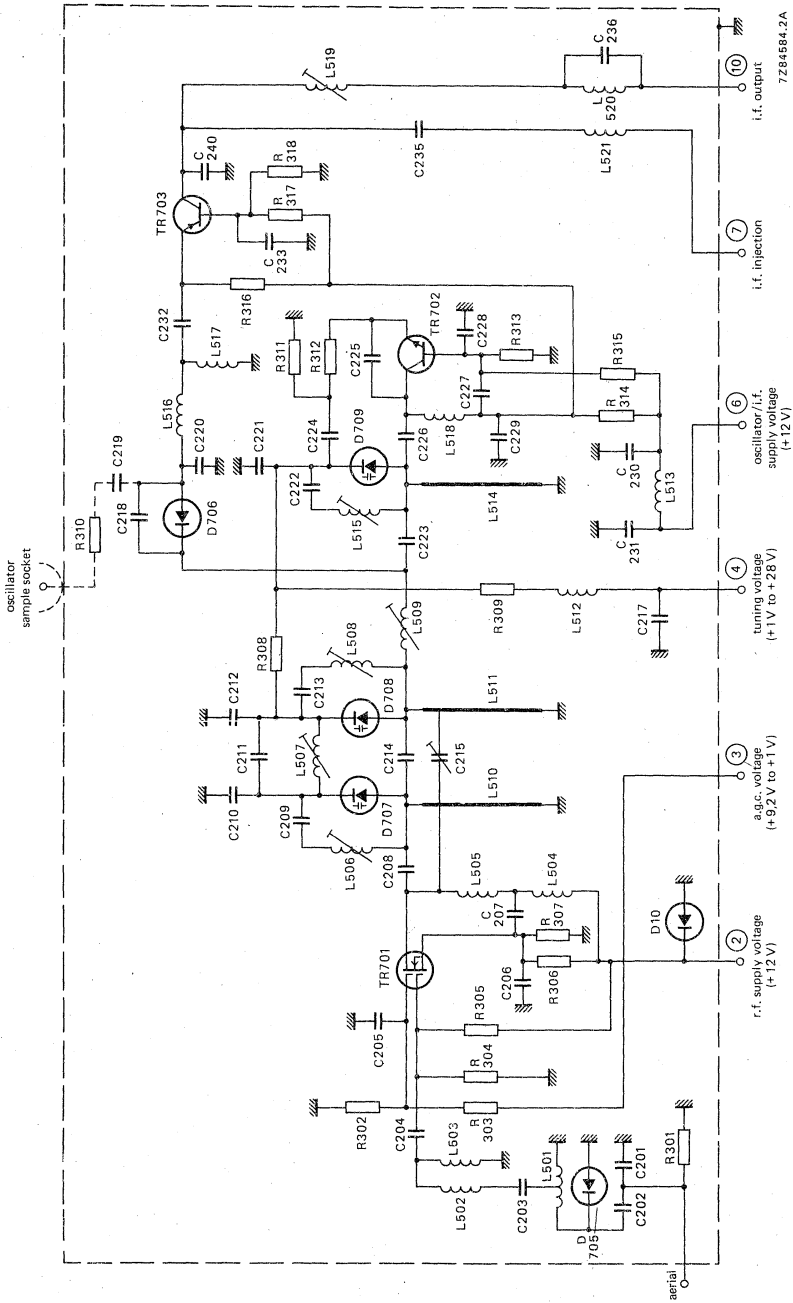

Fig. 1.

MECHANICAL DATA

Dimensions in mm

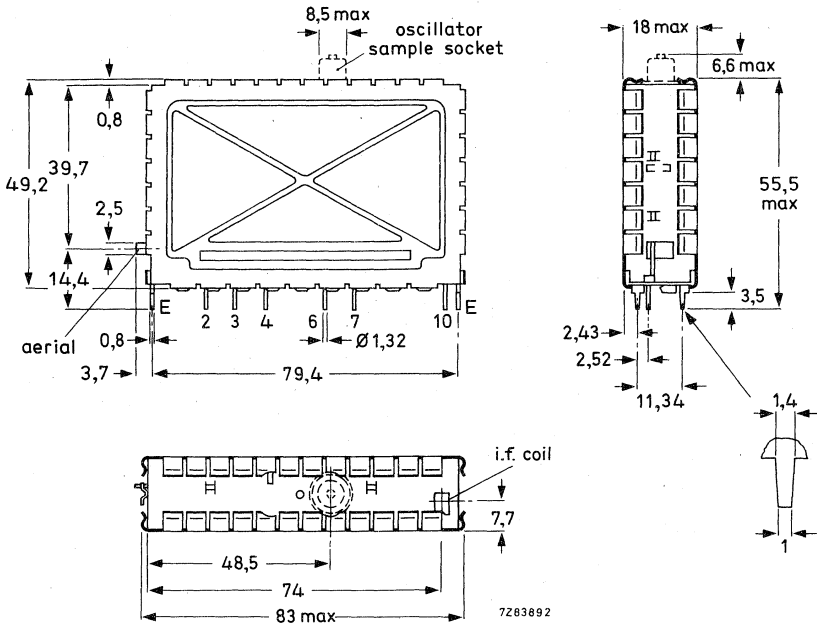

Fig. 2a The oscillator sample socket, drawn with dotted lines, applies only to tuner U341LO.

Terminal

- 2 = r.f. supply voltage, + 12 V
- 3 = a.g.c. voltage + 9,2 to + 1 V
- 4 = tuning voltage, + 1 to + 28 V
- 6 = oscillator/i.f. supply voltage, + 12 V
- 7 = i.f. injection point
- 10 = i.f. output

Note: When the tuner is operated together with a v.h.f. tuner, only the supply voltage at terminal 6 should be switched off during v.h.f. operation.

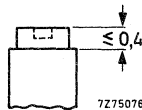

Fig. 2b I.F. output coil.
Torque for alignment: 2 to 15 mNm
Press-through force: ≥ 10 N

Mass approx. 75 g

Mounting

The tuner may be mounted by soldering it on to a printed-wiring board with connections as shown by the piercing diagram in Fig. 3. (The tuner may also be mounted in a socket. Information will be supplied upon request.)

It is recommended that the tuner be installed in a cool part of the receiver cabinet and not exposed to the vibrations of the loudspeaker. There are no restrictions on orientation.

The solderability of the terminals and mounting tabs is according to IEC 68-2, test Ta ($230 \pm 10 \text{ }^\circ\text{C}$, $2 \pm 0,5 \text{ s}$). The resistance to soldering heat is according to IEC 68-2, test Tb ($260 \pm 5 \text{ }^\circ\text{C}$, $10 \pm 1 \text{ s}$).

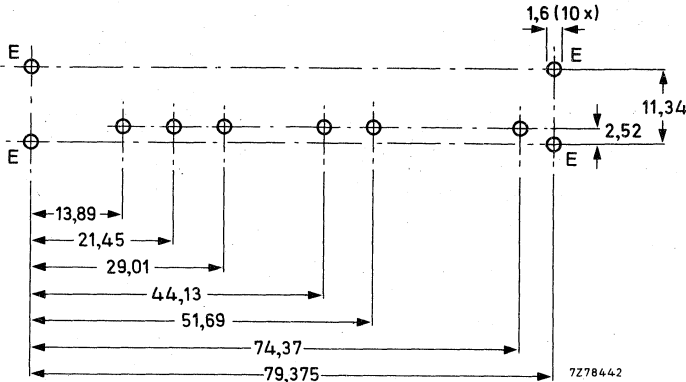

Fig. 3 Piercing diagram viewed from solder side of board.

A coaxial plug has to be used for connection to the socket on the top of tuner U341LO; type 3/2-50 (manufacturer: Daut und Rietz) is recommended.

The aerial cable should be connected as follows:

- strip the cable according to Fig. 4B;
- fix the cable as indicated in Fig. 4C and solder the inner conductor on the aerial tag;
- insert lugs on immunity shield under the tabs on tuner body, push the shield into position so that the locating tags snap into place in the tuner body.

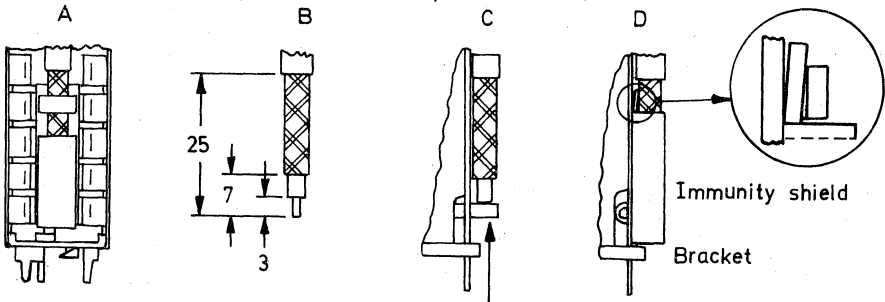

Fig. 4 Fixing of the aerial cable. Inner conductor soldered on aerial tag
Recommended cable: DAVU wire CX4004 (outer sheath diameter 5,32 mm).

7280026

ELECTRICAL DATA

The electrical values are measured on the u.h.f. tuner alone, but they are also valid for the u.h.f. tuner when used with a v.h.f. tuner V317 or V334. Unless otherwise specified all electrical values apply at an ambient temperature of 25 ± 5 °C, a relative humidity of $60 \pm 15\%$, a supply voltage of $12 \pm 0,3$ V and an a.g.c. voltage of $9,2 \pm 0,2$ V.

Within the given tolerance range of supply voltage and a.g.c. voltage only insignificant deviations from the specified values can be expected. Under the extreme conditions of temperature and humidity as given below, the tuner will function normally, but some specified limits may be exceeded.

General

Semiconductors

→	r.f. amplifier	BF980 (3SK87)
	mixer diode	1SS99
	oscillator	BF480
	tuning diodes	3 x BB405B
	i.f. amplifier	BF324
→	surge protection diodes	2 x BAV10

Ambient temperature range

operating	+5 to +55 °C
storage	-25 to +85 °C

Relative humidity

max. 90%

Voltages and currents

Supply voltage $+12$ V \pm 10%

Note: The supply voltage at terminal 2 (input stage) should be filtered to avoid hum modulation.

Current drawn from +12 V supply

r.f. amplifier, at nominal gain	typ.	21 mA
r.f. amplifier, at 30 dB gain reduction	typ.	10 mA
oscillator/i.f. amplifier	max.	16 mA

A.G.C. voltage (Fig. 5), at nominal gain $+9,2 \pm 0,5$ V

A.G.C. voltage, at 30 dB gain reduction min. +1 V

Note: A.G.C. voltages between 0 and +10 V may be applied without risk of damage.

A.G.C. current (Fig. 5)

during gain control (0 to 30 dB)	max.	+1 mA
at nominal gain	typ.	+0,9 mA
at 30 dB gain reduction	typ.	+0,1 mA

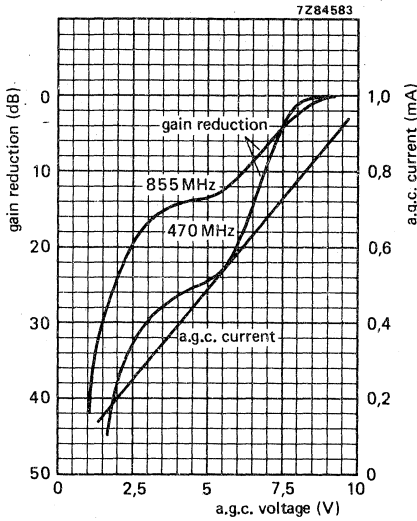

Fig. 5.

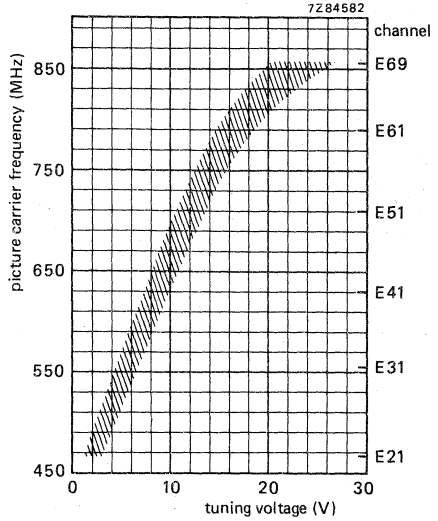

Fig. 6.

Tuning voltage range (Fig. 6)

Current drawn from +28 V tuning voltage supply
at 25 °C
at 55 °C

Slope of tuning characteristic

Note: The source impedance of the tuning voltage offered to terminal 4 must be maximum 47 kΩ at tuning voltages below 3 V.

Oscillator sample signal; only valid for U341LO

at +12 V supply voltage and
 $T_{amb} = \pm 25\text{ °C}$
within the given tolerance range of supply
voltage and given operating temperature range,
and within the tuning voltage range +0,5 to +30 V

+1 to +28 V

max. 0,15 μA

max. 0,6 μA

min. 4 MHz/V

typ. 90 dB (μV) into 75 Ω

min. 80 dB (μV) into 75 Ω

max. 100 dB (μV) into 75 Ω

Note: A tuning voltage higher than +28 V will not damage the tuner and may be applied at the user's own risk. Under this condition the published reverse voltage limit of the oscillator tuning diode will be exceeded; the oscillator frequency will never decrease with increasing tuning voltage.

Frequencies

Frequency range

channel E21 (picture carrier 471,25 MHz)
to channel E69 (picture carrier 855,25 MHz).
Margin at the extreme channels: min. 3 MHz.

Intermediate frequencies

picture

sound

systems I, K	systems G, H
39,5 MHz	38,9 MHz
33,5 MHz	33,4 MHz

The oscillator frequency is higher than the
aerial signal frequency.

Note: The tuner is aligned in such a way that the i.f. frequencies of the four systems can be applied.

Wanted signal characteristics

Input impedance

asymmetrical

75 Ω

Output impedance at the oscillator sample socket; **only valid for U341LO**

asymmetrical

75 Ω

V.S.W.R. and reflection coefficient

at picture carrier frequency, at

nominal gain and at 30 dB gain reduction

v.s.w.r.

max. 6

reflection coefficient

max. 71%

V.S.W.R. and reflection coefficient* at oscillator sample socket: **only valid for U341LO**

v.s.w.r. at $f_{osc} < 600$ MHz

max. 4 (typ. 3)

v.s.w.r. at $f_{osc} > 600$ MHz

max. 3 (typ. 2)

reflection coefficient at $f_{osc} < 600$ MHz

max. 60% (typ. 50%)

reflection coefficient at $f_{osc} > 600$ MHz

max. 50% (typ. 33%)

R.F. curves, bandwidth

typ. 18 MHz

R.F. curves, tilt (only for i.f. 39,5/33,5 MHz)

on any channel the amplitude difference
between the top of the r.f. resonant curve and
the picture carrier marker, the sound carrier
marker, or any frequency between them will
not exceed 3 dB at nominal gain, and 4 dB in
the a.g.c. range between nominal gain and
20 dB gain reduction.

A.G.C. range

min. 30 dB

* Measured in operational and non-operational condition of the tuner.

Power gain (see also Measuring method of power gain)	min.	18 dB
channel E21	typ.	23 dB
channel E40	typ.	22 dB
channel E69	typ.	22 dB
Gain difference between any two channels	typ.	4 dB
Noise figure	max.	10 dB
channel E21	typ.	6,5 dB
channel E40	typ.	6,5 dB
channel E69	typ.	7 dB
Overloading		
Input signal producing 1 dB gain compression at nominal gain	typ.	90 dB (μ V) into 75 Ω
Input signal producing either a detuning of the oscillator of +300 kHz or -1000 kHz or stopping of the oscillations at nominal gain	typ.	100 dB (μ V) into 75 Ω
Unwanted signal characteristics		
Image rejection (measured at picture carrier frequency)		
at nominal gain, channels E21 to E60	min.	53 dB; typ. 60 dB
at 20 dB gain reduction, channels E21 to E60	min.	50 dB
Harmonic content of oscillator sample; only valid for U341LO		
Suppression of harmonics which fall into the frequency range below 1200 MHz (second harmonics of fundamentals below 600 MHz)	min.	15 dB (typ. 20 dB) below oscillator fundamental
R.F. rejection at oscillator sample socket; only valid for U341LO		
Signal voltage at oscillator sample socket (input signals of wanted frequency 70 dB (μ V) into 75 Ω ; tuner operating at nominal gain)	min.	17 dB (typ. 24 to 34 dB) below oscillator fundamental
I.F. rejection (measured at picture carrier and colour sub-carrier frequency)	min.	60 dB
I.F. rejection at oscillator sample socket; only valid for U341LO		
I.F. signals at oscillator sample socket (converted from input signals of wanted frequency 70 dB (μ V) into 75 Ω ; tuner operating at nominal gain)	min.	20 dB (typ. 35 dB) below oscillator fundamental

$N \pm 4$ rejection

Interference signal for an interference ratio of

53 dB referred to wanted picture carrier (picture

to sound carrier ratio of 7 dB; wanted signal 60 dB (μV); tuner operating at nominal gain)

$N + 4$ rejection typ. 80 dB (μV) into 75 Ω

$N - 4$ rejection typ. 73 dB (μV) into 75 Ω

Cross modulation

Input signal producing 1% cross modulation, i.e. 1% of the modulation depth of the interfering signal is transferred to the wanted signal.

In channel cross modulation (wanted signal: picture carrier frequency; interfering signal: sound carrier frequency)

at nominal gain (wanted input level 60 dB (μV)) typ. 80 dB (μV) into 75 Ω

at 26 dB gain reduction (wanted input level 86 dB (μV)) typ. 100 dB (μV) into 75 Ω

In band cross modulation (wanted signal: picture carrier of channel N ; interfering signal: picture carrier of channel $N \pm 3$ and $N \pm 5$)

at nominal gain (wanted input level 60 dB (μV)) typ. 92 dB (μV) into 75 Ω

at 26 dB gain reduction (wanted input level 86 dB (μV)) typ. 100 dB (μV) into 75 Ω

Out of band cross modulation, at nominal gain

v.h.f. I min. 108 dB (μV) into 75 Ω

v.h.f. III min. 108 dB (μV) into 75 Ω

Oscillator characteristics

Pulling

Input signal of tuned frequency producing a shift of the oscillator frequency of 10 kHz, at nominal gain

typ. 80 dB (μV) into 75 Ω

Shift of oscillator frequency

at a change of the supply voltage of 5%

max. 550 kHz

Drift of oscillator frequency

during warm-up time (after the tuner has been completely out of operation for 15 min, measured between 5 s and 15 min after switching on)

max. 250 kHz

during warm-up time (after the input stage is in operation for 15 min, measured between 2 s and 15 min after switching on the oscillator/i.f. stage)

max. 250 kHz

at a change of the ambient temperature from + 25 to + 50 °C (measured after 3 cycles from + 25 to + 55 °C)

channels E21 to E60
channels E61 to E69

U341	U341LO
max. 1000 kHz	
max. 1200 kHz	

at a change of the ambient temperature from + 25 to + 40 °C (measured after 3 cycles from + 25 to + 55 °C)

channels E21 to E60
channels E61 to E65
channels E66 to E69

max. 500 kHz	max. 500 kHz
max. 650 kHz	max. 800 kHz
max. 750 kHz	max. 1000 kHz

I.F. characteristics

Bandwidth of i.f. output circuit

$5^{+1}_{-0.5}$ MHz

Note: I.F. output of the tuner terminated with the circuit shown in Fig. 7 tuning voltage 15 V.

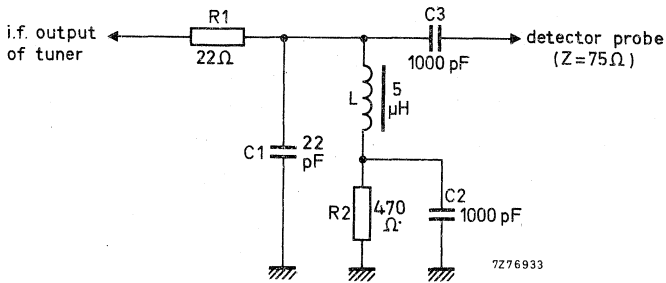

Fig. 7.

Bandwidth variation of i.f. output circuit as a result of r.f. tuning

max. 500 kHz

Note: I.F. output of the tuner terminated with a modified circuit of Fig. 7, i.e. a 100 pF capacitor is connected in parallel with C1; tuning voltage 15 V.

Detuning of the i.f. output circuit as a result of r.f. tuning

max. 500 kHz

Note: I.F. output of the tuner terminated with a modified circuit of Fig. 7, i.e. a 100 pF capacitor is connected in parallel with C1; tuning voltage 15 V.

Minimum tuning range of i.f. output coil 33 to 40 MHz
Note: I.F. output of the tuner terminated with the circuit shown in Fig. 7; tuning voltage 15 V.

Attenuation between i.f. injection point and i.f. output of the tuner 23 ± 3 dB

Miscellaneous

Radio interference
Oscillator radiation and oscillator voltage at the aerial terminal

Within the limits of C.I.S.P.R. 13 (1975), and BS905*.

Immunity from radiated interference

Aerial terminal meets requirements of BS 905, provided the tuner is installed in a professional manner.

Microphonics

There will be no microphonics, provided the tuner is installed in a professional manner.

Surge protection

Protection against voltages

max. 5 kV

Note: Three discharges of a 470 pF capacitor into the aerial terminal.

Protection against flashes

max. 30 kV, 400 mWs

Note: A flashover circuit producing flashes with frequencies of 1 to 20 Hz for 30 s is connected to the aerial terminal.

* For U341LO: when the oscillator sample socket is either open or terminated with a coaxial plug (75 Ω impedance, e.g. type 3/2-50, Daut und Rietz).

ADDITIONAL INFORMATION

I.F. injection

The tuner has an i.f. injection point at the collector of the i.f. transistor (coupled via a small capacitor to terminal 7). The i.f. generator can be connected directly to this point (Fig. 8).

The tuner needs normal supply voltages and a tuning voltage of 15 V; the i.f. output should be loaded with the circuit shown in Fig. 7.

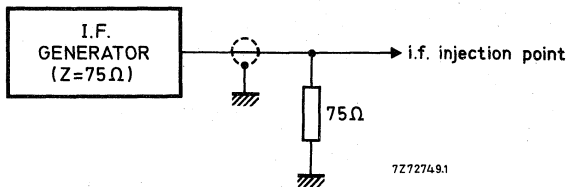

Fig. 8.

Connection of the i.f. amplifier

The tuner needs a d.c. path from the i.f. output terminal (10) to earth, preferably via a choke of approx. $5 \mu\text{H}$ outside the tuner (Fig. 9). Where the tuner is used in combination with a v.h.f. tuner, this choke can be common for both tuners; a resistor in series with the choke can inhibit the i.f. output circuit of the switched-off tuner. For damping the i.f. output circuit and matching the i.f. output impedance of the tuner to the receiver i.f. amplifier, a series resistor and a parallel capacitor as shown in Fig. 9 should be used.

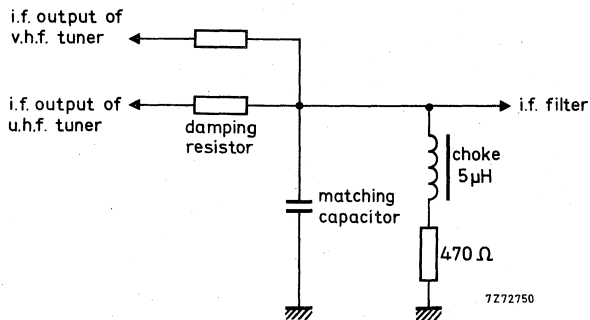

Fig. 9.

Measuring method of power gain

The i.f. output of the tuner should be terminated with the RC-circuit given in Fig. 7.

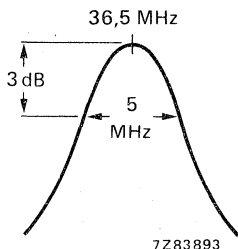

Fig. 10.

The RC-circuit roughly matches the i.f. output impedance to 75Ω at the resonant frequency of the i.f. output circuit, which should be tuned to 36,5 MHz; the bandwidth should be approx. 5 MHz (Fig. 10).

Because the input and output impedances of the tuner are now 75Ω , the power gain can be measured in the conventional manner by inserting tuner and RC-circuit between a 75Ω source and a 75Ω detector.

Alignment of the i.f. output coil

The i.f. output coil should be adjusted with a brass tool with a blade as shown in Fig. 11. A suitable tool is available under catalogue number 7122 005 47680.

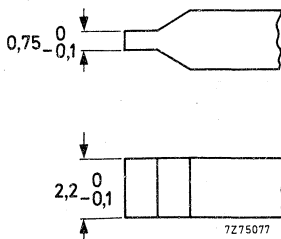

Fig. 11.

ACCESSORIES

Immunity shield, catalogue number 3122 121 24910

Connector assembly for use of tuner U341 or U341LO in combination with v.h.f. tuner V317 or V334: connector, catalogue number 3112 200 20720;

clamp holder, catalogue number 3122 121 29260;

clamp, catalogue number 3112 274 13220.

U.H.F. TELEVISION TUNERS

QUICK REFERENCE DATA

Systems	C.C.I.R. systems G, H, I and K		
Channels	E21 to E69		
Intermediate frequencies	systems G and H	systems I and K	
	picture	38,9 MHz	39,5 MHz
	sound	33,4 MHz	33,5 MHz

APPLICATION

These tuners are designed to cover the u.h.f. channels E21 to E69 of C.C.I.R. systems G, H, I and K. In combination with a suitable v.h.f. tuner, e.g. V317 or V334, they can be used in v.h.f./u.h.f. receivers. The aerial inputs and i.f. outputs of both tuners can then be connected in parallel.

The U342LO is a special version of the U342; an output voltage from the local oscillator is made available for driving digital tuning systems. Apart from this the tuners are identical.



DESCRIPTION

The tuners are u.h.f. tuners with electronic tuning, covering the u.h.f. band from 470 to 860 MHz.

Mechanically, the tuners are built on a printed-wiring board, carrying all components, in a metal housing made of a rectangular frame, and front and rear covers (see Fig. 2a). All connections (aerial, supply voltages, a.g.c. voltage, tuning voltage, i.f. injection, i.f. output) are made via terminals on the underside. The mounting method is shown in Fig. 3. Tuner U342LO has a coaxial socket on the top of the frame for coupling out the oscillator sample.

Electrically, the tuners consist of an input circuit with a high-pass characteristic and a MOS-FET tetrode BF980. This tetrode operates at a drain current of about 10 mA, featuring good noise figures and good signal handling properties. It also acts as an a.g.c. device, controlled by an a.g.c. voltage fed to gate 2. This combination has good signal handling properties throughout the a.g.c. range. The drain load of the MOS-FET tetrode is formed by a double tuned circuit, transferring the signal to the mixer diode 1SS99. The selectivity of this circuit at the image frequency has been improved by special means. The mixer diode is driven by an oscillator, equipped with a transistor BF480. At the U342LO the oscillator sample is coupled out of the mixer via a small capacitor in series with a resistor.

The i.f. signal, originated in the mixer, is amplified by a transistor BF324 in grounded-base configuration. The combination of the Schottky-barrier diode 1SS99 and the i.f. transistor BF324 also features good noise figures and good signal handling properties. Three capacitance diodes BB405B tune the double tuned circuit and the oscillator.

The i.f. output circuit of the tuner is a single tuned one, at the low end of which the i.f. signal is coupled out of the tuner. A d.c. path to earth for the collector current of the i.f. transistor BF324 has to be provided outside the tuner, preferably by a choke of about 5 μ H. Damping of the i.f. output circuit and matching of the i.f. output to the i.f. circuit of the receiver can be achieved by connecting a series resistance and a parallel capacitance outside the tuner.

An i.f. injection point has been provided at the collector of the i.f. transistor, connected to terminal 7.

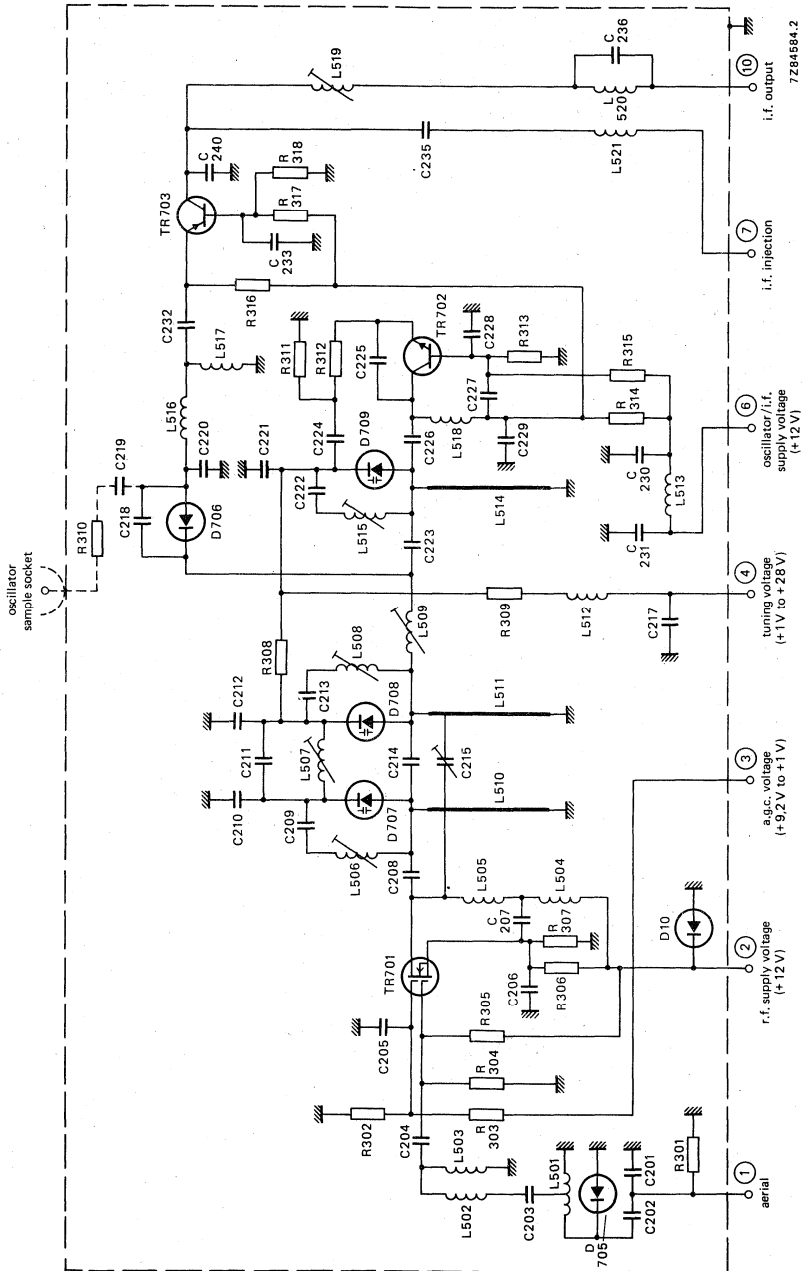

Fig. 1.

MECHANICAL DATA

Dimensions in mm

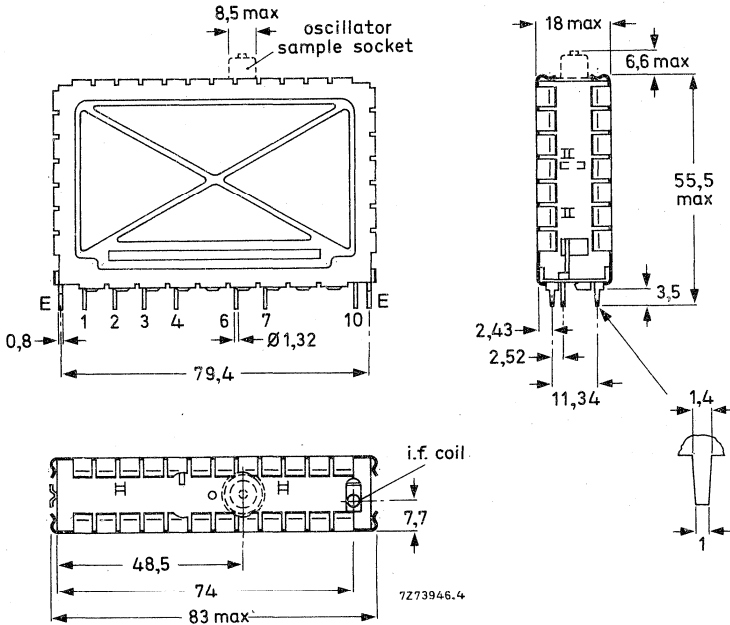

Fig. 2a The oscillator sample socket, drawn with dotted lines, applies only to tuner U342LO.

Terminal 1 = aerial

2 = r.f. supply voltage, +12 V

3 = a.g.c. voltage, +9,2 to +1 V

4 = tuning voltage, +1 to +28 V

6 = oscillator/i.f. supply voltage, +12 V

7 = i.f. injection point

10 = i.f. output

Note: When the tuner is operated together with a v.h.f. tuner, only the supply voltage at terminal 6 should be switched off during v.h.f. operation.

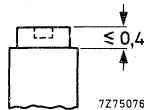

Fig. 2b I.F. output coil.

Torque for alignment: 2 to 15 mNm

Press-through force: ≥ 10 N

Mass approx. 75 g

Mounting

The tuner may be mounted by soldering it on to a printed-wiring board, using the piercing diagram shown in Fig. 3. (The tuner may also be mounted into a socket. Information will be supplied upon request.)

It is recommended that the tuner be installed in the cool part of the receiver cabinet and not exposed to the vibrations of the loudspeaker. There are no restrictions on orientation.

The solderability of the terminals and mounting tabs is according to IEC 68-2, test Ta ($230 \pm 10 \text{ }^\circ\text{C}$, $2 \pm 0,5 \text{ s}$). The resistance to soldering heat is according to IEC 68-2, test Tb ($260 \pm 5 \text{ }^\circ\text{C}$, $10 \pm 1 \text{ s}$).

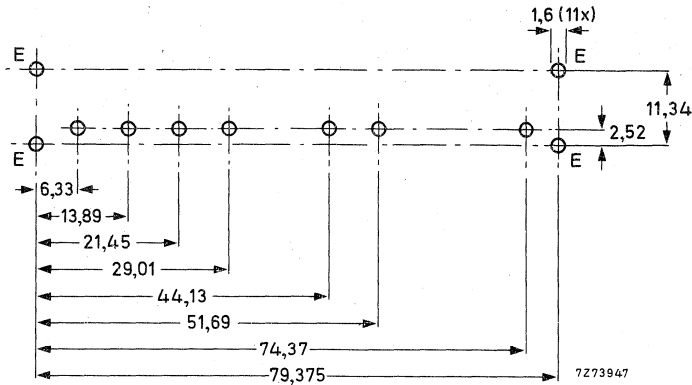

Fig. 3 Piercing diagram viewed from solder side of board.

For connection to the socket on the top of tuner U342LO a coaxial plug has to be used; type 3/2-50 (manufacturer: Daut und Rietz) is recommended.

ELECTRICAL DATA

The electrical values are measured on the u.h.f. tuner alone, but they are also valid for the u.h.f. tuner in combination with a v.h.f. tuner V317 or V334. Unless otherwise specified all electrical values apply at an ambient temperature of 25 ± 5 °C, a relative humidity of $60 \pm 15\%$, a supply voltage of $12 \pm 0,3$ V and an a.g.c. voltage of $9,2 \pm 0,2$ V.

Within the given tolerance range of supply voltage and a.g.c. voltage only insignificant deviations from the specified values can be expected. Under the extreme conditions of temperature and humidity as given below, the tuner will function normally, but some specified limits may be exceeded.

General

Semiconductors

→	r.f. amplifier	BF980 (3SK87)
	mixer diode	1SS99
	oscillator	BF480
	tuning diodes	3 x BB405B
	i.f. amplifier	BF324
→	surge protection diodes	2 x BAV10

Ambient temperature range

operating	+ 5 to + 55 °C
storage	-25 to + 85 °C

Relative humidity

max. 90%

Voltages and currents

Supply voltage + 12 V \pm 10%

Note: The supply voltage at terminal 2 (input stage) should be filtered to avoid hum modulation.

Current drawn from + 12 V supply

r.f. amplifier, at nominal gain	typ. 21 mA
r.f. amplifier, at 30 dB gain reduction	typ. 10 mA
oscillator/i.f. amplifier	max. 16 mA

A.G.C. voltage (Fig. 4), at nominal gain + 9,2 \pm 0,5 V

A.G.C. voltage, at 30 dB gain reduction min. + 1 V

Note: A.G.C. voltages between 0 and + 10 V may be applied without risk of damage.

A.G.C. current (Fig. 4)

during gain control (0 to 30 dB)	max. + 1 mA
at nominal gain	typ. + 0,9 mA
at 30 dB gain reduction	typ. + 0,1 mA

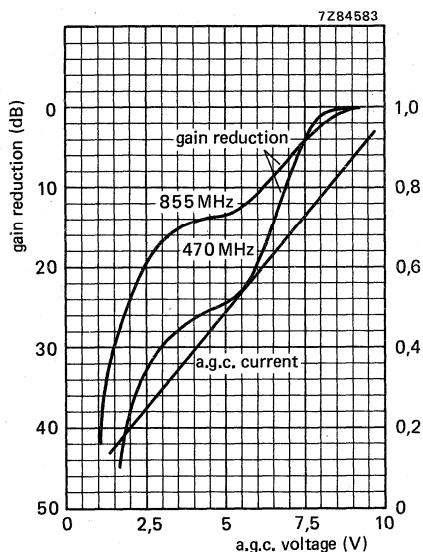

Fig. 4.

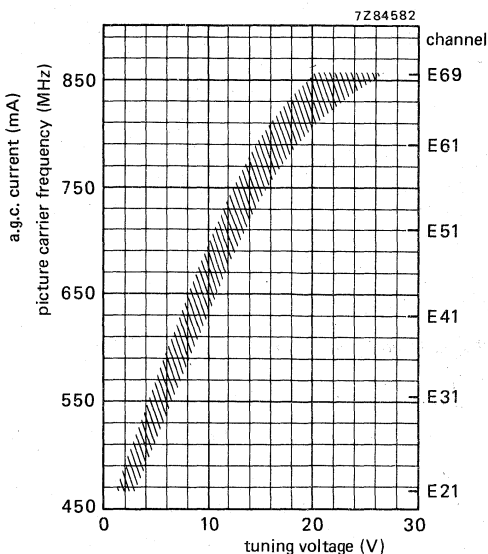

Fig. 5.

Tuning voltage range (Fig. 5)

Current drawn from +28 V tuning voltage supply
at 25 °C
at 55 °C

Slope of tuning characteristic

Note: The source impedance of the tuning voltage offered to terminal 4 must be maximum 47 kΩ at tuning voltages below 3 V.

Oscillator sample signal; only valid for U342LO

at +12 V supply voltage and

$T_{amb} = +25\text{ °C}$

within the given tolerance range of supply

voltage and given operating temperature range,

and within the tuning voltage range +0,5 to +30 V

+1 to +28 V

max. 0,15 μA

max. 0,6 μA

min. 4 MHz/V

typ. 90 dB (μV) into 75 Ω

min. 80 dB (μV) into 75 Ω

max. 100 dB (μV) into 75 Ω

Note: A tuning voltage higher than +28 V will not be harmful for the tuner and may be applied at the user's own risk. Under this condition the published reverse voltage limit of the oscillator tuning diode will be exceeded; the oscillator frequency will never decrease with increasing tuning voltage.

Frequencies

Frequency range

channel E21 (picture carrier 471,25 MHz)
to channel E69 (picture carrier 855,25 MHz).
Margin at the extreme channels: min. 3 MHz.

Intermediate frequencies

picture
sound

systems G, H	systems I, K
38,9 MHz	39,5 MHz
33,4 MHz	33,5 MHz

The oscillator frequency is higher than the aerial signal frequency.

Note: The tuner is aligned in such a way that the i.f. frequencies of the four systems can be applied.

Wanted signal characteristics

Input impedance

asymmetrical

75 Ω

Output impedance at the oscillator sample socket; **only valid for U342LO**

asymmetrical

75 Ω

V.S.W.R. and reflection coefficient

at picture carrier frequency, at

nominal gain and at 30 dB gain reduction

v.s.w.r.

max. 6

reflection coefficient

max. 71%

V.S.W.R. and reflection coefficient* at oscillator sample socket: **only valid for U342LO**

v.s.w.r. at $f_{osc} < 600$ MHz

max. 4 (typ. 3)

v.s.w.r. at $f_{osc} > 600$ MHz

max. 4 (typ. 2)

reflection coefficient at $f_{osc} < 600$ MHz

max. 60% (typ. 50%)

reflection coefficient at $f_{osc} > 600$ MHz

max. 50% (typ. 33%)

R.F. curves, bandwidth

typ. 18 MHz

R.F. curves, tilt (only for i.f. 38,9/33,4 MHz)

on any channel the amplitude difference between the top of the r.f. resonant curve and the picture frequency, the sound frequency, or any frequency between them will not exceed 3 dB at nominal gain, and 4 dB in the a.g.c. range between nominal gain and 20 dB gain reduction.

A.G.C. range

min. 30 dB

* Measured in operational and non-operational condition of the tuner.

Power gain (see also Measuring method of power gain)	min.	20 dB
channel E21	typ.	25 dB
channel E40	typ.	24 dB
channel E69	typ.	27 dB
Gain difference between any two channels	typ.	4 dB
Noise figure	max.	10 dB
channel E21	typ.	6 dB
channel E40	typ.	6 dB
channel E69	typ.	6,5 dB
Overloading		
Input signal producing 1 dB gain compression at nominal gain	typ.	90 dB (μ V) into 75 Ω
Input signal producing either a detuning of the oscillator of +300 kHz or -1000 kHz or stopping of the oscillations at nominal gain	typ.	100 dB (μ V) into 75 Ω
Unwanted signal characteristics		
Image rejection (measured at picture carrier frequency)		
channels E21 to E60	min.	46 dB; typ. 53 dB
Harmonic content of oscillator sample; only valid for U342LO		
Suppression of harmonics which fall into the frequency range below 1200 MHz (second harmonics of fundamentals below 600 MHz)	min.	15 dB (typ. 20 dB) below oscillator fundamental
R.F. rejection at oscillator sample socket; only valid for U342LO		
Signal voltage at oscillator sample socket (input signals of wanted frequency 70 dB (μ V) into 75 Ω ; tuner operating at nominal gain)	min.	17 dB (typ. 24 to 34 dB) below oscillator fundamental
I.F. rejection (measured at picture carrier and colour sub-carrier frequency)	min.	60 dB
I.F. rejection at oscillator sample socket; only valid for U342LO		
I.F. signals at oscillator sample socket (converted from input signals of wanted frequency 70 dB (μ V) into 75 Ω ; tuner operating at nominal gain)	min.	20 dB (typ. 35 dB) below oscillator fundamental



N ± 4 rejection

Interference signal for an interference ratio of 53 dB referred to wanted picture carrier (picture to sound carrier ratio of 10 dB; wanted signal 60 dB(μV); tuner operating at nominal gain)

typ. 80 dB (μV) into 75 Ω

Cross modulation

Input signal producing 1% cross modulation, i.e. 1% of the modulation depth of the interfering signal is transferred to the wanted signal.

In channel cross modulation (wanted signal: picture carrier frequency; interfering signal: sound carrier frequency)

at nominal gain (wanted input level 60 dB (μV))

typ. 80 dB (μV) into 75 Ω

at 26 dB gain reduction (wanted input level 86 dB (μV))

typ. 100 dB (μV) into 75 Ω

In band cross modulation (wanted signal: picture carrier of channel N; interfering signal: picture carrier of channel N ± 5)

at nominal gain (wanted input level 60 dB (μV))

typ. 92 dB (μV) into 75 Ω

at 26 dB gain reduction (wanted input level 86 dB (μV))

typ. 100 dB (μV) into 75 Ω

Out of band cross modulation, at nominal gain

v.h.f. I

min. 108 dB (μV) into 75 Ω

v.h.f. III

min. 108 dB (μV) into 75 Ω

Oscillator characteristics

Pulling

Input signal of tuned frequency producing a shift of the oscillator frequency of 10 kHz, at nominal gain

typ. 80 dB (μV) into 75 Ω

Shift of oscillator frequency

at a change of the supply voltage of 5%

max. 550 kHz

Drift of oscillator frequency

during warm-up time (after the tuner has been completely out of operation for 15 min, measured between 5 s and 15 min after switching on)

max. 250 kHz

during warm-up time (after the input stage is in operation for 15 min, measured between 2 s and 15 min after switching on the oscillator/i.f. stage)

max. 250 kHz

at a change of the ambient temperature from +25 to +40 °C (measured after 3 cycles from +25 to +55 °C)

channels E21 to E60

channels E61 to E65

channels E66 to E69

U342	U342LO
max. 500 kHz	max. 500 kHz
max. 650 kHz	max. 800 kHz
max. 750 kHz	max. 1000 kHz

I.F. characteristics

Bandwidth of i.f. output circuit

$5^{+1}_{-0,5}$ MHz

Note: I.F. output of the tuner terminated with the circuit shown in Fig. 6; tuning voltage 15 V.

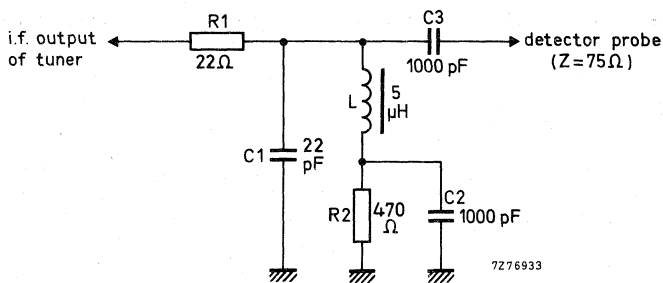

Fig. 6.

Bandwidth variation of i.f. output circuit as a result of r.f. tuning

max. 500 kHz

Note: I.F. output of the tuner terminated with a modified circuit of Fig. 6, i.e. a 100 pF capacitor is connected in parallel with C1; tuning voltage 15 V.

Detuning of the i.f. output circuit as a result of r.f. tuning

max. 500 kHz

Note: I.F. output of the tuner terminated with a modified circuit of Fig. 6, i.e. a 100 pF capacitor is connected in parallel with C1; tuning voltage 15 V.

Minimum tuning range of i.f. output coil 33 to 40 MHz
Note: I.F. output of the tuner terminated with the circuit shown in Fig. 6; tuning voltage 15 V.

Attenuation between i.f. injection point and i.f. output of the tuner typ. 23 ± 3 dB

Miscellaneous

Radio interference
Oscillator radiation and oscillator voltage at the aerial terminal Within the limits of C.I.S.P.R. 13 (1975) and VDE 0872/7.72*

Microphonics There will be no microphonics, provided the tuner is installed in a professional manner.

Surge protection
Protection against voltages max. 5 kV

Note: Three discharges of a 470 pF capacitor into the aerial terminal.

Protection against flashes max. 30 kV, 400 mWs

Note: A flashover circuit producing flashes with frequencies of 1 to 20 Hz for 30 s is connected to the aerial terminal.



* For U342LO: when the oscillator sample socket is either open or terminated with a coaxial plug (75 Ω impedance, e.g. type 3/2-50, Daut und Rietz).

ADDITIONAL INFORMATION

I.F. injection

The tuner is provided with an i.f. injection point at the collector of the i.f. transistor (coupled via a small capacitor to terminal 7). The i.f. generator can be connected directly to this point (Fig. 7). The tuner needs normal supply voltages and a tuning voltage of 15 V; the i.f. output should be loaded with the circuit shown in Fig. 6.

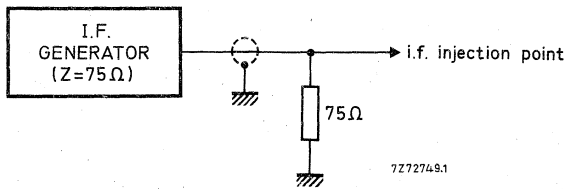

Fig. 7.

Connection of the i.f. amplifier

The tuner needs a d.c. path from the i.f. output terminal (10) to earth, preferably via a choke of approx. $5\ \mu\text{H}$ outside the tuner (Fig. 8). Where the tuner is used in combination with a v.h.f. tuner, this choke can be common for both tuners; a resistor in series with the choke can make ineffective the i.f. output circuit of the switched-off tuner. For damping the i.f. output circuit and matching the i.f. output impedance of the tuner to the i.f. amplifier, a series resistor and a parallel capacitor as shown in Fig. 8 should be used.

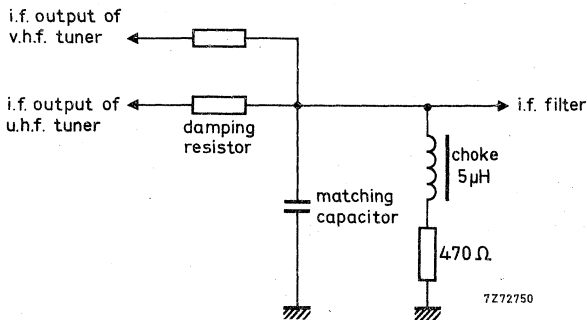

Fig. 8.

Measuring method of power gain

The i.f. output of the tuner should be terminated with the RC-circuit given in Fig. 6.

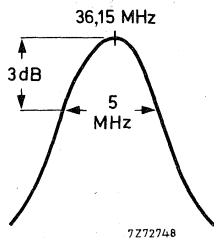

Fig. 9.

The RC-circuit roughly matches the i.f. output impedance to 75Ω at the resonant frequency of the i.f. output circuit, which should be tuned to 36,15 MHz; the bandwidth should be approx. 5 MHz (Fig. 9).

Because the input and output impedances of the tuner are now 75Ω , the power gain can be measured in the conventional manner by inserting tuner and RC-circuit between a 75Ω source and a 75Ω detector.

Alignment of the i.f. output coil

The i.f. output coil should be adjusted with a brass tool with a blade as shown in Fig. 10. A suitable tool is available under catalogue number 7122 005 47680.

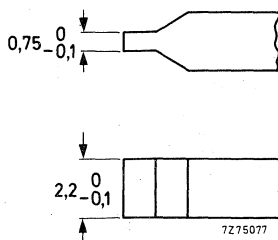

Fig. 10.

ACCESSORIES

Connector assembly for use of tuner U342 or U342LO in combination with v.h.f. tuner V317 or V334:
connector, catalogue number 3112 200 20720;
washer, catalogue number 3112 221 01220;
clamp, catalogue number 3112 274 13220.

U.H.F. TELEVISION TUNERS

QUICK REFERENCE DATA

Systems	C.C.I.R. systems I (United Kingdom), G, H and K	
Channels	E21 to E69	
Intermediate frequencies	systems G and H	systems I and K
picture	38,9 MHz	39,5 MHz
sound	33,4 MHz	33,5 MHz

APPLICATION

Designed to cover the u.h.f. channels of C.C.I.R. systems I, G, H and K in u.h.f. single standard receivers. They meet the special requirements of the United Kingdom. Tuner U412 is equipped with a frequency divider, which makes this type suitable for digital tuning systems based on frequency synthesis; for the remainder it is equal to type U411.



DESCRIPTION

The U411 and U412 are u.h.f. tuners with electronic tuning. They meet the special requirements of the United Kingdom and are pin-compatible with the UV411, UV413, UV415, and the UV412, UV414, UV416 respectively. Mechanically, the tuners are built on a low-loss printed-wiring board, carrying all components, in a metal housing made of a rectangular frame and front and rear covers (see Fig. 2a). The coaxial aerial connection of $75\ \Omega$ is on one of the frame sides, all other connections (supply voltages, a.g.c. voltage, tuning voltage, i.f. output) are made via terminals in the underside. The mounting method is shown in Fig. 3.

Electrically (see Fig. 1), the tuners consist of a bandpass input circuit connected to gate 1 of an input MOSFET tetrode (with internal gate protection against surge). The drain load of this MOSFET tetrode is formed by a double tuned circuit transferring the r.f. signal to the Schottky barrier mixer diode.

The selectivity of this circuit at the image frequency is such that it meets the stringent requirements of the U.K.

The i.f. signal from the mixer is amplified by an i.f. transistor connected in grounded-base configuration. The combination of Schottky barrier diode and i.f. transistor ensures good noise figures and good signal handling properties.

The double tuned circuit and the oscillator circuit are tuned by 3 BB405B capacitance diodes. The i.f. output circuit of the tuner is a single tuned circuit, at the low end of which the i.f. signal is coupled out of the tuner. A test point (terminal 4) is provided for i.f. injection to align the i.f. output circuit of the tuner together with the i.f. amplifier of the television receiver. An additional test point, which is accessible through a hole in the top of the tuner, is connected to the collector of the i.f. amplifier transistor. The tuner is gain controlled via gate 2 of the input MOSFET tetrode.

The electrical circuit of the U412 is extended with a frequency divider (division ratio of 256) the inputs of which are connected to the oscillator. The outputs are balanced; they are connected to terminals 12 and 13. The output voltage is determined by the external load and the supply voltage, which is connected to this load. They should be chosen such that:

- The output voltage rating of 10 V is not exceeded;
- The output voltage does not drop more than 1,6 V below 5 V supply voltage of frequency divider);
- The output voltage swing does not exceed 1 V.

Radiation by the output signal may be reduced by transporting the two complementary signals via twisted wires or a flat cable, even if only one signal is to be used to drive the subsequent circuit.



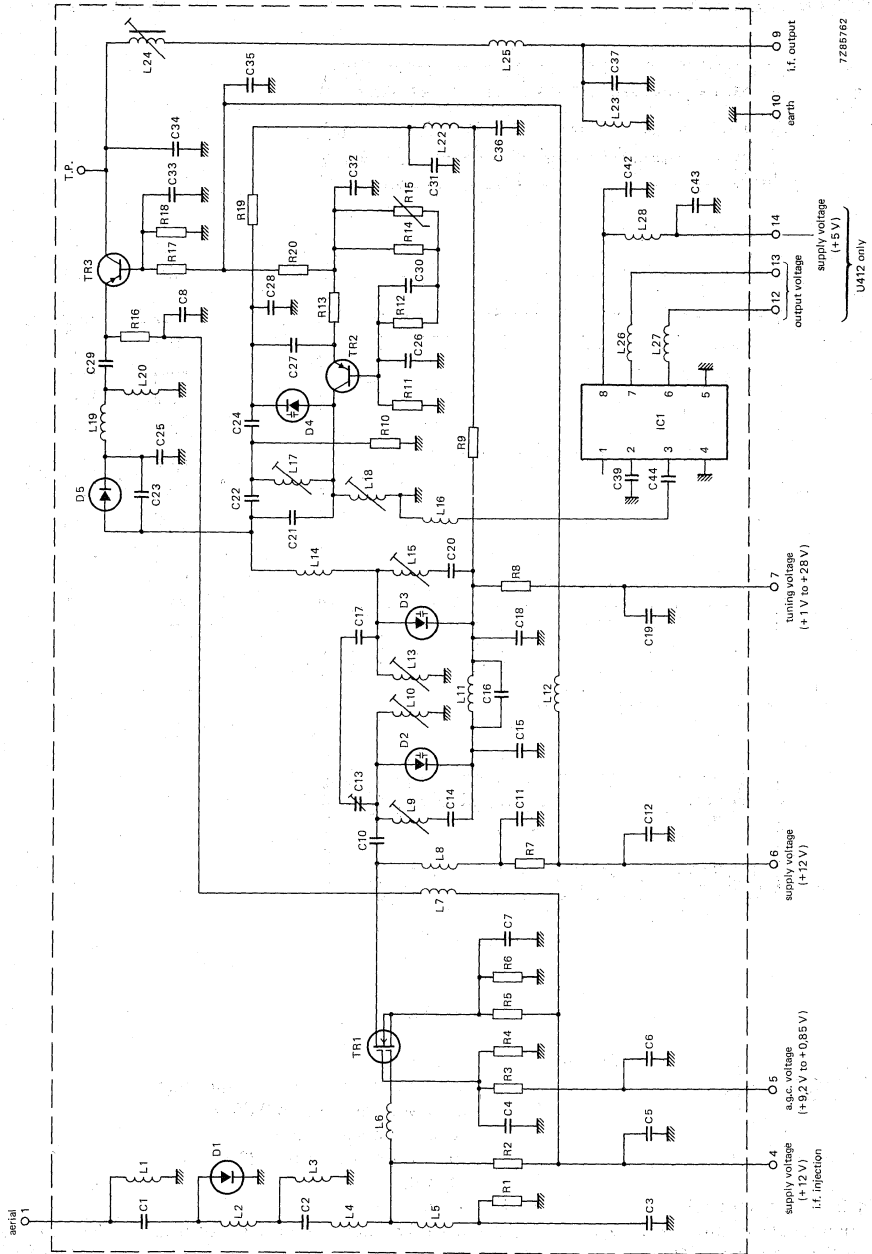

Fig. 1.



U411
U412

3112 218 51790
3112 218 51810

MECHANICAL DATA

Dimensions in mm

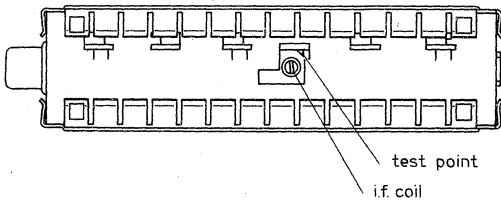
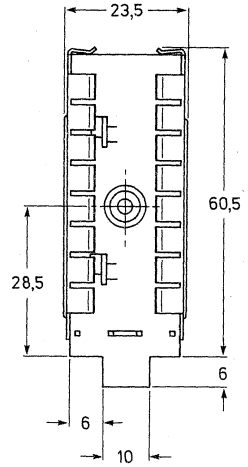
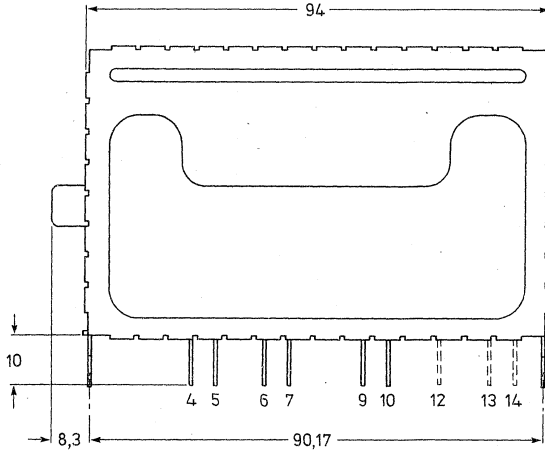
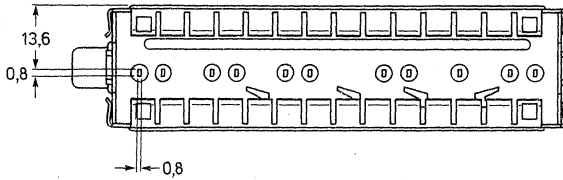

7285763

Fig. 2a.

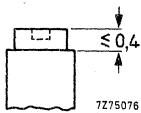

Fig. 2b I.F. output coil.
Torque for alignment: 2 to 15 mNm.
Press-through force: ≥ 10 N.

- | | | |
|------------|--|-----------------|
| Terminal 1 | = aerial | |
| 4 | = supply voltage, + 12 V; i.f. injection | |
| 5 | = a.g.c. voltage, + 9,2 to 0,85 V | |
| 6 | = supply voltage, + 12 V | |
| 7 | = tuning voltage, + 1 to + 28 V | |
| 9 | = i.f. output | |
| 10 | = earth | |
| 12,13 | = balanced output voltage of frequency divider | } only for U412 |
| 14 | = supply voltage, frequency divider, + 5 V | |

Mass approx. 93 g

Mounting

The tuner may be mounted by soldering it on to a printed-wiring board, using the piercing diagram shown in Fig. 3. The tuner may be mounted anywhere in the receiver and there are no restrictions on orientation. However it is recommended that it is placed in the cool part of the cabinet and away from loudspeaker vibrations.

The solderability of the terminals and mounting tabs (except cut edges) is according to IEC 68-2, test Ta (230 ± 10 °C, $2 \pm 0,5$ s). The resistance to soldering heat is according to IEC 68-2, test Tb (260 ± 5 °C, 10 ± 1 s).

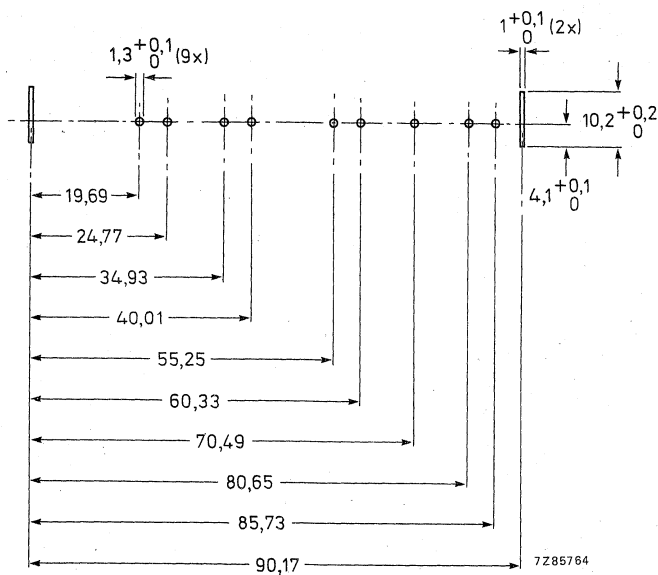

Dimensions in mm

(1) only for U412.

Fig. 3 Piercing diagram viewed from solder side of board. Unless otherwise stated the tolerance is $\pm 0,05$ mm.

ELECTRICAL DATA

Unless otherwise specified all electrical values apply at an ambient temperature of $25 \pm 5^\circ\text{C}$, a relative humidity of $60 \pm 15\%$, a supply voltage of $12 \pm 0,3\text{ V}$ and an a.g.c. voltage of $9,2 \pm 0,2\text{ V}$.

General

Semiconductors

r.f. input MOSFET transistor	BF980 (3SK87)
oscillator transistor	BF970
i.f. amplifier transistor	BF324
mixer diode	1SS99
tuning diodes	3 x BB405B
surge protection diode	BAV10
frequency divider	SP4653

Ambient temperature range

operating	0 to $+55^\circ\text{C}$
storage	-25 to $+70^\circ\text{C}$

Relative humidity

max. 95%

Voltages and currents

Supply voltage

$+12\text{ V} \pm 10\%$

Current drawn from $+12\text{ V}$ supply

max. 45 mA; typ. 34 mA

A.G.C. voltage

voltage range	$+9,2$ to $+0,85\text{ V}$
voltage at nominal gain	$+9,2 \pm 0,5\text{ V}$
voltage at 30 dB gain reduction	min. 1 V

Note: A.G.C. voltages between 0 and $+10,5\text{ V}$ may be applied without risk of damage.

A.G.C. current

max. 0,2 mA

Slope of a.g.c. characteristic at end of specified range

type. 50 dB/V

Tuning voltage range

$+1$ to $+28\text{ V}$

Current drawn from 28 V tuning voltage supply

at $T_{\text{amb}} = 25^\circ\text{C}$ and 60% relative humidity	max. 0,25 μA
at $T_{\text{amb}} = 25^\circ\text{C}$ and 95% relative humidity	max. 1,0 μA
at $T_{\text{amb}} = 55^\circ\text{C}$ and 60% relative humidity	max. 1,0 μA

Slope of tuning characteristic

channel E21	typ. 22 MHz/V
channel E69	typ. 5 MHz/V

Note: the source impedance of the tuning voltage must be maximum 47 k Ω .

Fig. 4 Typical a.g.c. characteristic, bands IV and V.

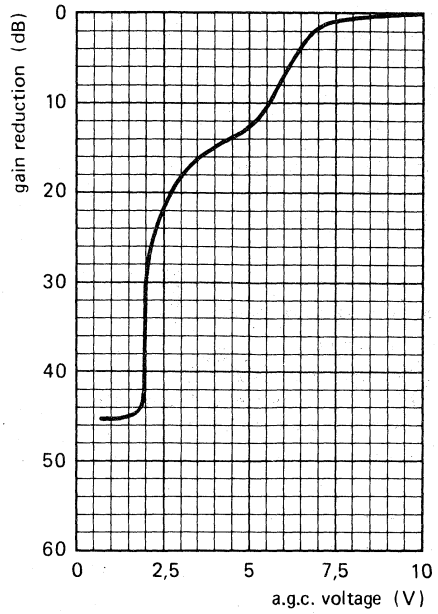
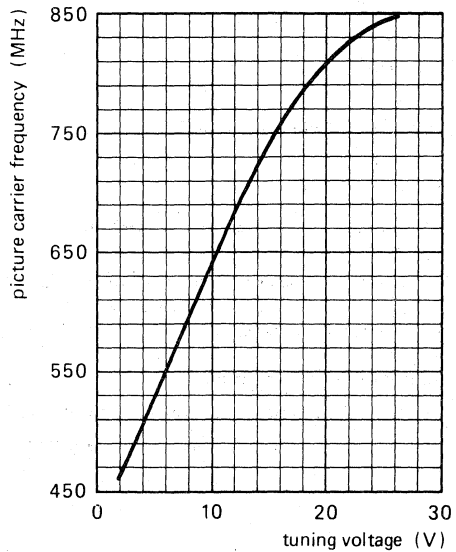

Fig. 5 Typical tuning characteristic, bands IV and V.



Frequencies

Frequency range
bands IV and V

Intermediate frequencies
picture
sound

Channel E21 (picture carrier 471,25 MHz) to channel E69 (picture carrier 855,25 MHz). Margin at the extreme channels: min. 3 MHz.

systems G and H	systems I and K
38,9 MHz	39,5 MHz
33,4 MHz	33,5 MHz

The oscillator frequency is higher than the aerial signal frequency.

Wanted signal characteristics

Input impedance

75 Ω

V.S.W.R. and reflection coefficient
(values between picture and sound carrier, as well as values at picture carrier)

v.s.w.r.
reflection coefficient

at nominal gain	during gain control
max. 5	max. 6
max. 66%	max. 71%

R.F. curves, bandwidth

typ. 24 MHz

R.F. curves, tilt

on any channel the amplitude difference between the top of the r.f. resonant curve and either the picture frequency, or the sound frequency, or any frequency between them will not exceed 3 dB at nominal gain, and 4 dB in the a.g.c. range between nominal gain and 20 dB gain reduction.

A.G.C. range

min. 30 dB

Power gain

min. 20 dB

Maximum gain difference between any two channels

typ. 4 dB

Noise figure

max. 10 dB

Overloading

Input signal producing 1 dB gain compression at nominal gain

typ. 90 dB (μV) into 75 Ω

Input signal producing either a detuning of the oscillator of + 300 kHz or -1000 kHz or stopping of the oscillations at nominal gain

typ. 100 dB (μV) into 75 Ω

Unwanted signal characteristics

Image rejection (measured at picture carrier frequency)

min. 53 dB; type. 50 dB

I.F. rejection (measured at picture carrier frequency)

min. 60 dB



N ± 4 rejection

Interference signal for an interference ratio of 53 dB referred to wanted picture carrier (picture to sound carrier ratio of 7 dB; wanted signal 60 dB (μV); tuner operating at nominal gain)

interfering signal N + 4
interfering signal N - 4

typ. 80 dB (μV) into 75 Ω
typ. 73 dB (μV) into 75 Ω

Cross modulation

Input signal producing 1% cross modulation, i.e. 1% of the modulation depth of the interfering signal is transferred to the wanted signal

Out of band modulation at nominal gain

v.h.f. I
v.h.f. III

typ. 108 dB (μV) into 75 Ω
typ. 108 dB (μV) into 75 Ω

Oscillator characteristics

Pulling

Input signal of tuned frequency producing a shift of the oscillator frequency of 10 kHz, at nominal gain

typ. 80 dB (μV) into 75 Ω

Shift of oscillator frequency at a change of the voltage of 5%

max. 500 kHz

Drift of oscillator frequency during warm-up time (after the tuner has been completely out of operation for 15 min, measured between 5 s and 15 min after switching on).

max. 250 kHz

Drift of oscillator frequency at a change of the ambient temperature from + 25 to + 50 °C (measured after 3 cycles from + 25 to + 55 °C)

max. 1000 kHz

I.F. circuit characteristics

Bandwidth of i.f. output circuit

5 ± 1 MHz

Note: I.F. output of the tuner terminated with the circuit shown in Fig. 6, tuning voltage 15 V.

Bandwidth variation of i.f. output circuit as a result of r.f. tuning; tuning voltage 15 V

max. 500 kHz

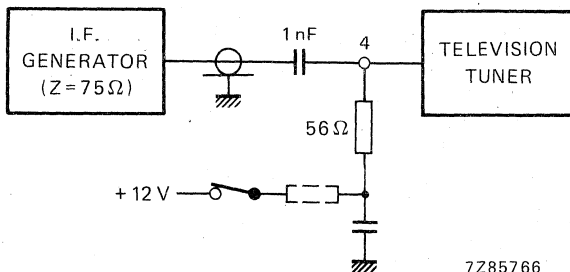

Fig. 6.

Attenuation between i.f. injection point and i.f. output of the tuner

typ. 18 dB

Miscellaneous

Radio interference

Oscillator radiation and oscillator voltage at the aerial terminal

Within the limits of C.I.S.P.R. 13 (1975)

Immunity from radiated interference

Meets the limits of BS905 (1969) with a reserve of at least 5 dB

Microphonics

There will be no microphonics, provided the tuner is installed in a professional manner.

Surge protection

Protection against voltages

max. 5 kV

Note: 10 discharges of a 470 pF capacitor into the aerial terminal.

Protection against flashes

max. 30 kV, 400 mWs

Note: A flashover circuit producing flashes with frequencies of 1 to 20 Hz for 30 s is connected to the aerial terminal.

ADDITIONAL INFORMATION

I.F. injection

Terminal 4 (supply voltage) can be used as i.f. injection point, provided the supply voltage is applied to terminal 4 via a resistor of 10 Ω (see Fig. 7). The tuning voltage should be 15 V.

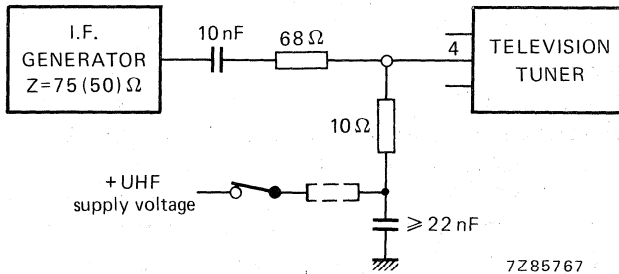

Fig. 7.

Connection of the i.f. amplifier

Connection to the i.f. amplifier should be either by a printed connection of minimum length or by a shielded connection such as a coaxial cable.

Measuring method of power gain

The i.f. output of the tuner should be terminated with the RC-circuit given in Fig. 6.

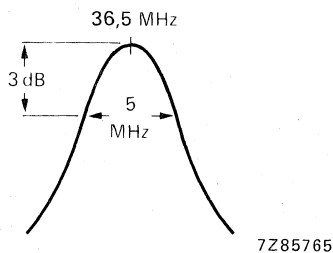

Fig. 8.

The RC-circuit roughly matches the i.f. output impedance to 75Ω at the resonant frequency of the i.f. output circuit, which should be tuned to $36,5 \text{ MHz}$; the bandwidth is approx. 5 MHz (Fig. 8). Because the input and output impedances of the tuner are now 75Ω , the power gain can be measured in the conventional manner by inserting tuner and RC-circuit between a 75Ω source and a 75Ω detector.

Alignment of the i.f. output coil

The i.f. output coil should be adjusted with a brass tool with a blade as shown in Fig. 9. A suitable tool is available under catalogue number 7122 005 47680.

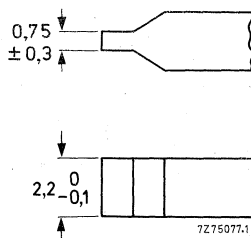

Fig. 9.

U.H.F. TELEVISION TUNER

with diode tuning

QUICK REFERENCE DATA

Systems	L (standard)
Channels	E21 to E69
Intermediate frequencies	
picture	32.7 MHz
sound	39.2 MHz

APPLICATION

This tuner covers u.h.f. channels E21 to E69 to meet the special requirements of television sets in France.



DESCRIPTION

The UF5 is a u.h.f. tuner with electronic tuning, covering the u.h.f. band from 470 to 860 MHz (channels E21 to E69).

The tuner circuit is built on a printed wiring board, and enclosed in a metal housing comprising a rectangular frame with front and rear covers. (See Fig. 2).

A shielded aerial lead is fitted to one of the shorter sides of the frame, all the other terminals (supply-input stage, a.g.c., tuning voltage, supply for oscillator and i.f. stage, i.f. injection and i.f. output) are made via connecting pins in the underside. Mounting is as shown in Figs 2 and 3.

Electrically, the tuner consists of an input circuit with high pass characteristic, followed by a transistor in grounded base configuration (see Fig. 1). The collector load of the input transistor is formed by a double tuned circuit with inductive bottom end coupling to the mixer stage. The i.f. signal, originated in the mixer stage, is amplified by a second transistor in grounded base configuration.

3-variable capacitance diodes tune the double tuned circuit and the oscillator.

The i.f. output signal is extracted from the low end of the double-tuned output circuit.

A d.c. path to ground for the collector current of the i.f. transistor is provided inside the tuner.

The sound i.f. frequency is 39,2 MHz and the vision i.f. frequency is 32,7 MHz.

CIRCUIT DIAGRAM

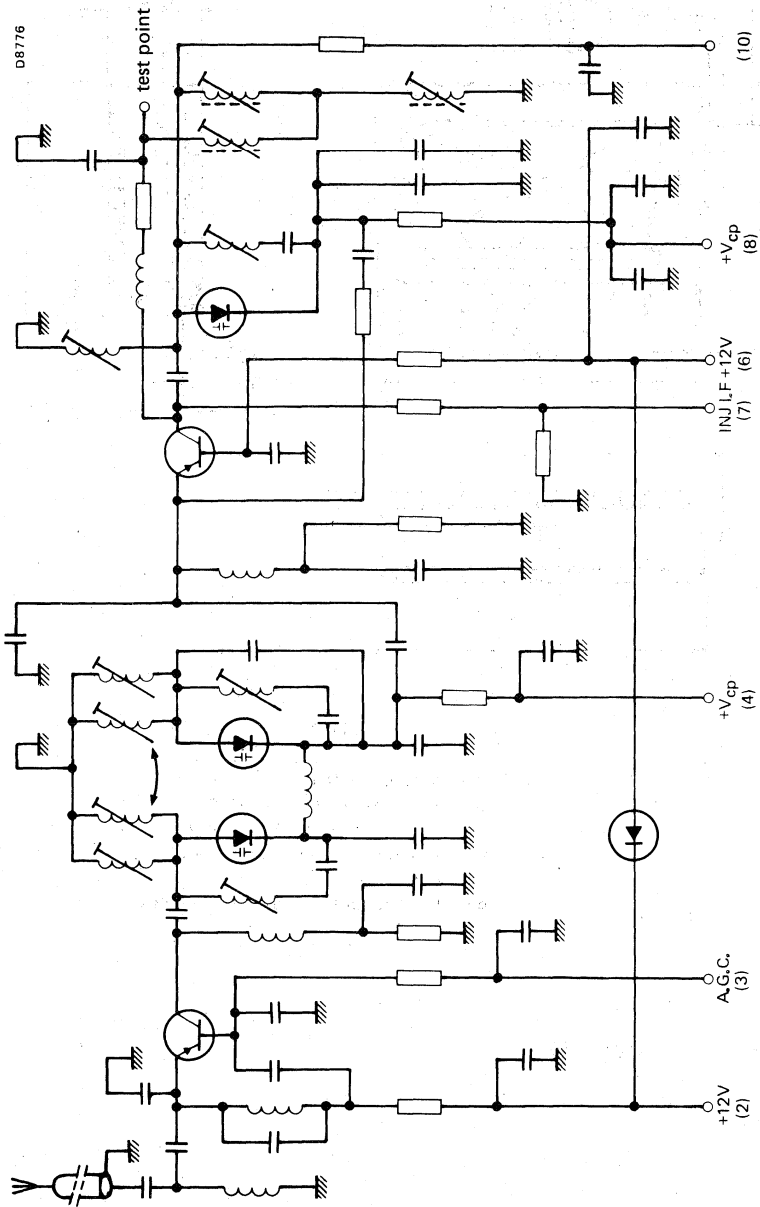

Fig. 1.

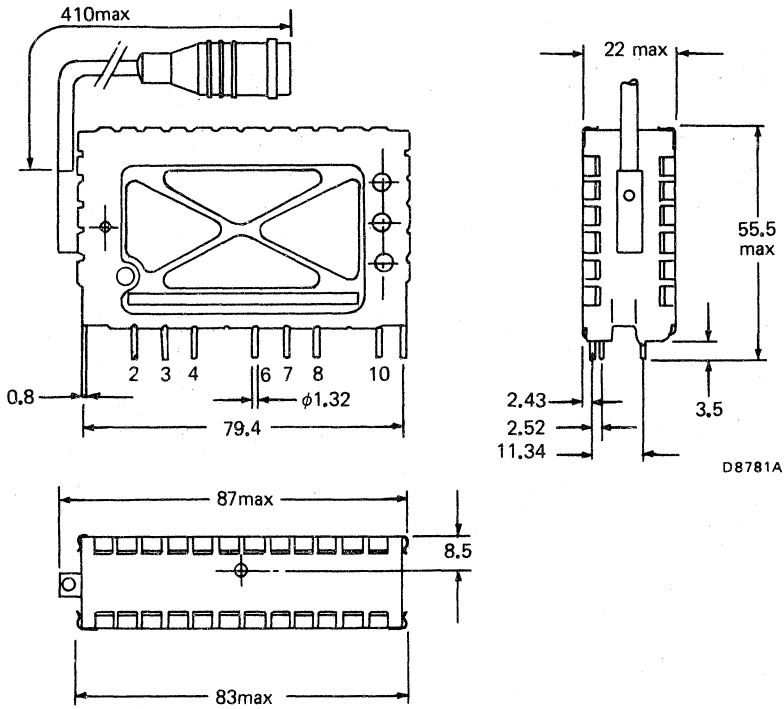

Fig. 2.

- 2 = r.f. supply voltage +12 V
- 3 = a.g.c. voltage +3.7 V to +8.5 V.
- 4 = tuning voltage r.f. +1 to +28 V
- 6 = oscillator/i.f. supply voltage, +12 V.
- 7 = i.f. injection point.
- 8 = tuning voltage oscillator +1 to +28 V.
- 10 = i.f. output

Mass approx. 75 g

Mounting

The tuner may be mounted by soldering it on to a printed-wiring board, with connections as shown by the piercing diagram in Fig. 3. (The tuner may also be mounted in a socket. Information will be supplied upon request).

It is recommended that the tuner be installed in a cool part of the receiver cabinet and not exposed to the vibrations of the loudspeaker. There are no restrictions on orientation.

The solderability of the terminals and mounting tabs is according to IEC 68-2, test Ta ($230 \pm 10 \text{ }^\circ\text{C}$, $2 \pm 0.5 \text{ s}$). The resistance to soldering heat is according to IEC 68-2, test Tb ($260 \pm 5 \text{ }^\circ\text{C}$, $10 \pm 1 \text{ s}$).

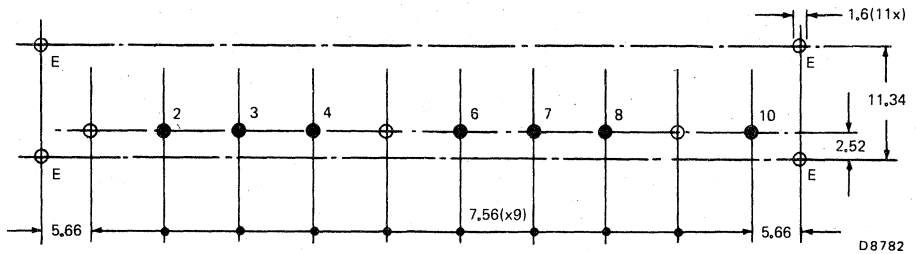

Fig. 3.

ELECTRICAL DATA

The electrical values are measured on the u.h.f. tuner alone. Unless otherwise specified all electrical values apply at an ambient temperature of 25 ± 5 °C, a relative humidity of $60 \pm 15\%$, a supply voltage of 12 ± 0.3 V and an a.g.c. current of -9 mA \pm 0.2 mA.

Within the given tolerance range of supply voltage and a.g.c. current, only insignificant deviations from the specified values can be expected.

Under the extreme conditions of temperature and humidity as given below, the tuner will function normally, but some specified limits may be exceeded.

Voltages and currents

Supply voltage +12 V \pm 1 V

Current drawn from 12 V supply

current at nominal gain typ. 8 mA

current at 30 dB gain reduction typ. 13 mA

A.G.C. voltage

at nominal gain 8.5 V

at 30 dB gain reduction 5.8 V

For a.g.c. characteristics see Fig.4

Tuning voltage range +0.3 to +28 V

Current drawn from +28 V tuning voltage supply max. 0.5 μ A

Slope of tuning characteristics see Fig.5

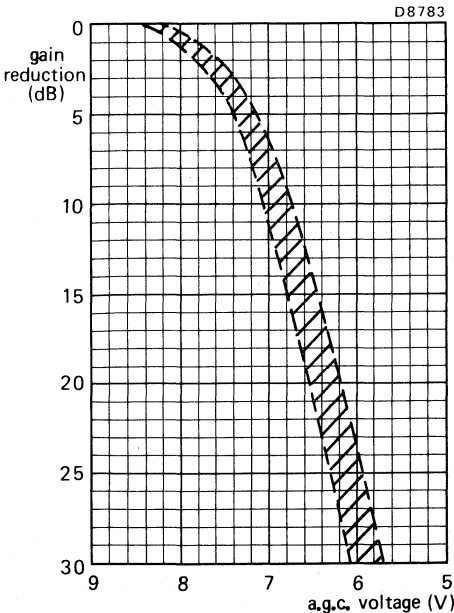

Fig. 4.

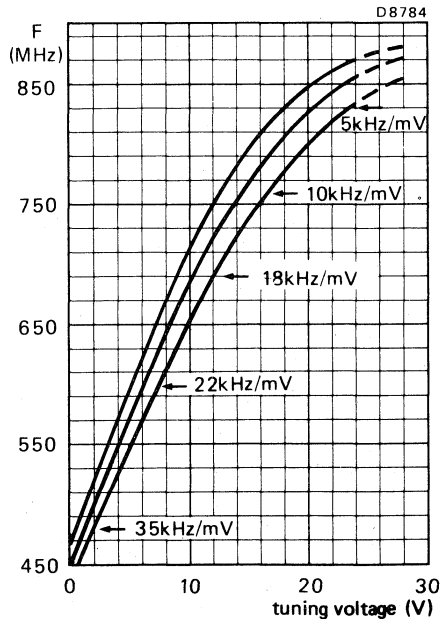

Fig. 5.

Frequencies

Frequency range	Channel 21 (vision 471.25 MHz, sound 477.75 MHz) Channel 69 (vision 855.25 MHz, sound 861.75 MHz).
Margin at extreme channels	min. 3 MHz
Intermediate frequency	
picture	32.7 MHz
sound	39.2 MHz

Wanted signal characteristics

Input impedance	
asymmetrical	75 Ω
V.S.W.R. at picture carrier frequency	
at nominal gain	≥ 4 dB
R.F. bandwidth	typ. 15 dB
R.F. tilt (only for i.f. 39.2/32.7 MHz)	On any channel the amplitude difference will not exceed ± 2 dB
A.G.C. dynamic range	≥ 30 dB
Reflection coefficient at picture carrier frequency	
at nominal gain	max. 66%
Power gain all channels	typ. 17 dB ≥ 14 dB
Noise figure all channels	≤ 9 dB typ. 6.5 dB

Unwanted signal characteristics

Image rejection (measured at picture frequency)	
channels 21 to 69	≥ 32 dB typ. 43 dB
I.F. rejection (measured at picture carrier and colour sub-carrier frequency)	min. 60 dB
$N \pm 3$ rejection	
Interference signal for an interference ratio of 53 dB referred to wanted signal (picture to sound carrier ratio of 7 dB, wanted signal 60 dB (μ V): tuner operating at nominal gain)	10 dB mV

Oscillator

Shift of oscillator frequency at a change of the supply voltage of 1 V.	typ. 400 kHz
Shift of oscillator frequency for a change in ambient temperature of 15 $^{\circ}$ C	\leq 550 kHz

ELECTRICAL DATA (continued)

I.F. circuit characteristics

The curve shows two peaks on the frequency characteristic curve, these peaks occur at the tuning point of the sound and vision carriers.

Vision peak at 32.7 MHz
 Sound peak at 39.2 MHz
 Deviation

0 dB
 0 ± 0.2 dB
 ≤ 1 dB

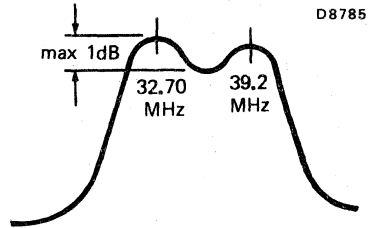

Miscellaneous

Radio interference
 Oscillator radiation and oscillator
 voltage at aerial terminal

Within the limits of C. I.S.P.R. 24/3
 (1970) and VDE 0872/7.72
 For the oscillator radiation use is
 made of the relaxed limit of 3 mV/m
 (70 dB μ V/m).

Microphonics

Microphony will not occur if the tuner is professionally installed.



V.H.F./U.H.F. TELEVISION TUNERS

QUICK REFERENCE DATA

Systems	C.C.I.R. systems B and G
Channels	
v.h.f. I	NZ1 to C
v.h.f. III	M4 to E12
u.h.f.	E21 to E69
Intermediate frequencies	
picture	38,9 MHz
sound	33,4 MHz

APPLICATION

Designed to cover the v.h.f. and u.h.f. channels of C.C.I.R. systems B and G, with extended v.h.f. frequency ranges.

Tuner UV412 is equipped with a frequency divider, which makes this type suitable for digital tuning systems based on frequency synthesis; for the remainder it is equal to type UV411.



DESCRIPTION

The UV411 and UV412 are combined v.h.f./u.h.f. tuners with electronic tuning and band switching, covering the v.h.f. band I including the New Zealand channel 1, and the Italian channel C (frequency range 44 to 92 MHz), the v.h.f. band III including the Morocco channel M4 (frequency range 162 to 230 MHz), and the u.h.f. band (frequency range 470 to 861 MHz).

Mechanically, the tuners are built on a low-loss printed-wiring board, carrying all components, in a metal housing made of a rectangular frame and front and rear covers (see Fig. 2). The common aerial connection (v.h.f. and u.h.f.) is on one of the frame sides, all other connections (supply voltages, a.g.c. voltage, tuning and switching voltages, i.f. output) are made via terminals in the underside. The mounting method is shown in Fig. 3.

Electrically, the tuners consist of v.h.f. and u.h.f. parts. The v.h.f. aerial signal is fed via switchable v.h.f. band I/III wide band input filters to gate 1 of an input MOSFET tetrode (with internal gate protection against surge).

The input filters are provided with an i.f. and f.m. suppression circuit. The drain load of the MOSFET tetrode is formed by a double tuned switchable bandpass filter, transferring the r.f. signal to the emitter of the mixer transistor. The oscillator signal is also fed to the emitter of the mixer transistor.

The collector circuit of the mixer transistor is a single tuned i.f. resonant circuit, at the low end of which the i.f. signal is coupled out of the tuner. A test point (terminal 4) is provided for i.f. injection to align the i.f. output circuit of the tuner together with the i.f. amplifier of the television receiver. An additional test point, which is accessible through a hole in the top of the tuner, is connected to the collector of the mixer transistor.

The r.f. band pass filter and oscillator circuits are tuned by 3 tuning diodes; band switching is achieved by 5 switching diodes.

The u.h.f. part of the tuner consists of a high-pass input circuit connected to gate 1 of an input MOSFET tetrode (with internal gate protection against surge). The drain load of this MOSFET tetrode is formed by a double tuned circuit transferring the r.f. signal to the Schottky barrier mixer diode. The i.f. signal from the mixer diode is amplified by the v.h.f. mixer transistor, now operating as an i.f. amplifier.

The r.f. band pass filter and oscillator circuits are tuned by 3 tuning diodes.

In all bands the tuner is gain controlled via gate 2 of the input MOSFET tetrode.

The electrical circuit of the UV412 is extended with a frequency divider SAB1077 (division ratio of 256), which inputs are connected to the v.h.f. and u.h.f. oscillator. The outputs are complementary open-collector current sources; they are connected to terminals 12 and 13. The output voltage is determined by the external load and the supply voltage, which is connected to this load. They should be chosen such that:

- the output-voltage rating of 10 V is not exceeded;
- the output voltage does not drop more than 1,6 V below 5 V (supply voltage of frequency divider);
- the output-voltage swing does not exceed 1 V.

Radiation by the output signal may be reduced by transporting the two complementary signals via twisted wires or a flat cable, even if only one signal is to be used to drive the subsequent circuit.

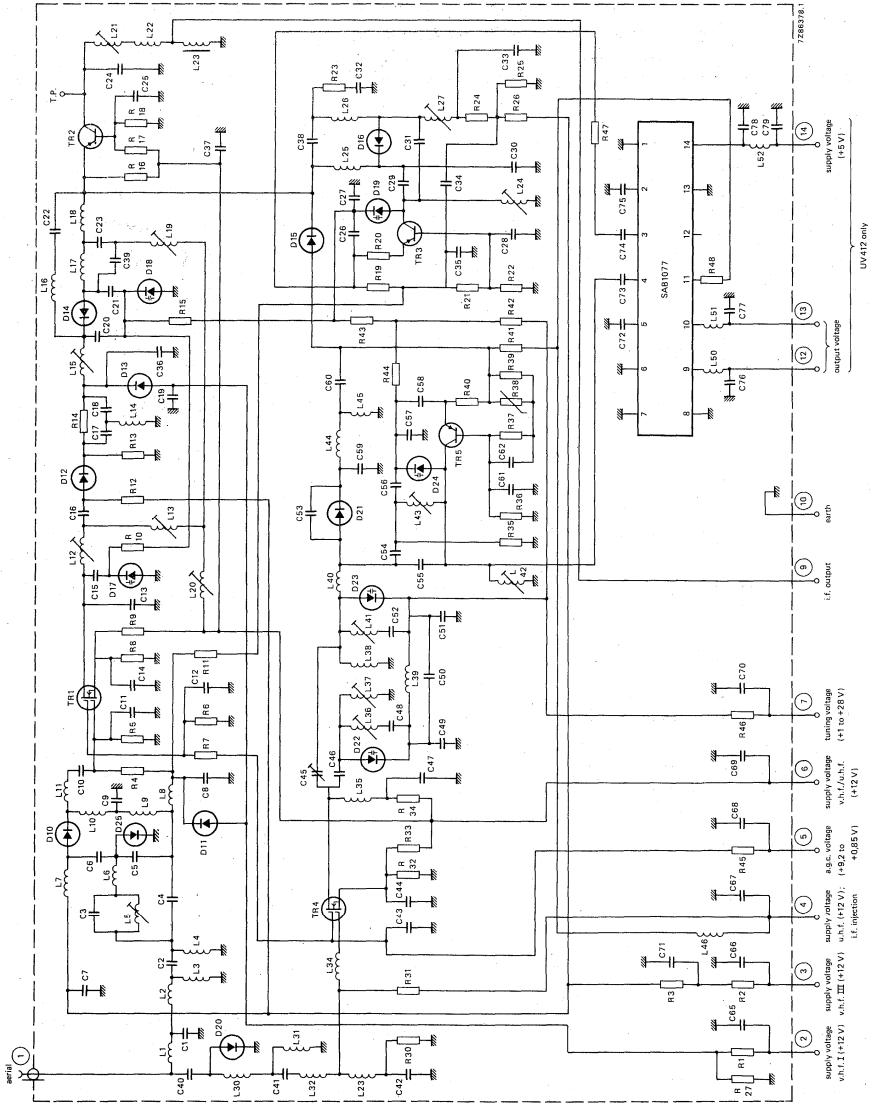
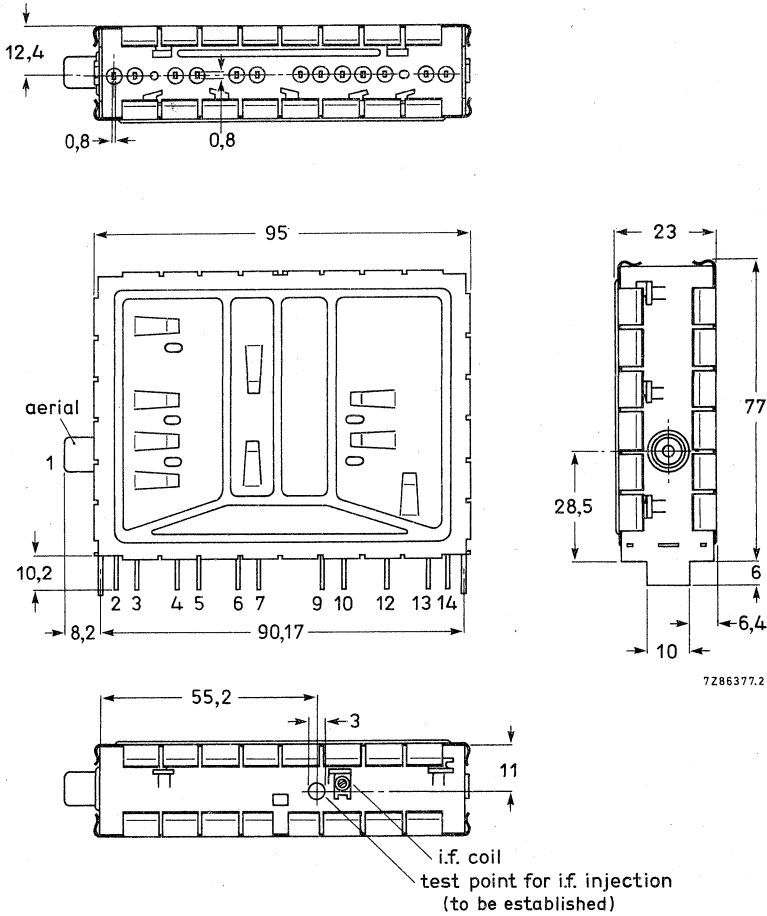

Fig. 1.



MECHANICAL DATA

Dimensions in mm



7Z86377.2

Fig. 2a.

- | | | |
|------------|--|------------------|
| Terminal 1 | = aerial | |
| 2 | = supply voltage, v.h.f. I, + 12 V | |
| 3 | = supply voltage, v.h.f. III, + 12 V | |
| 4 | = supply voltage, u.h.f., + 12 V; i.f. injection | |
| 5 | = a.g.c. voltage, + 9,2 to + 0,85 V | |
| 6 | = supply voltage, v.h.f. and u.h.f., + 12 V | |
| 7 | = tuning voltage, + 1 to + 28 V | |
| 9 | = i.f. output | |
| 10 | = earth | |
| 12,13 | = balanced output voltage of frequency divider | } only for UV412 |
| 14 | = supply voltage, frequency divider, + 5 V | |

Fig. 2b I.F. output coil.
Torque for alignment: 2 to 15 mNm.
Press-through force: ≥ 10 N.

Mass approx. 127 g

Mounting

The tuner may be mounted by soldering it on to a printed-wiring board, using the piercing diagram shown in Fig. 3. (The tuner may also be mounted by means of a bracket. Information will be supplied upon request.) The tuner may be mounted anywhere in the receiver and there are no restrictions on orientation.

The solderability of the terminals and mounting tabs is according to IEC68-2, test Ta (230 ± 10 °C, $2 \pm 0,5$ s). The resistance to soldering heat is according to IEC68-2, test Tb (260 ± 5 °C, 10 ± 1 s).

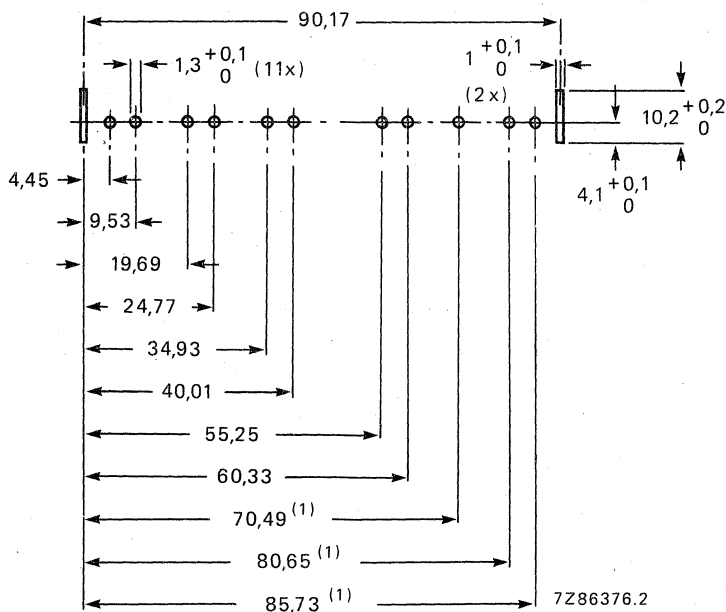

(1) Only for UV412.

Fig. 3 Piercing diagram viewed from solder side of board. Unless otherwise stated the tolerance is $\pm 0,05$ mm.

ELECTRICAL DATA

Unless otherwise specified all electrical values apply at an ambient temperature of $25 \pm 5^\circ\text{C}$, a relative humidity of $60 \pm 15\%$, a supply voltage of $12 \pm 0,3\text{ V}$ and an a.g.c. voltage of $9,2 \pm 0,2\text{ V}$.

General

Semiconductors, bands I and III

r.f. amplifier	BF982
mixer	BF324
oscillator	BF926
tuning diodes	3 x BB809
switching diodes	5 x BA482/483/484
d.c. blocking diodes	2 x BAW62

Semiconductors, bands IV and V

r.f. amplifier	BF980 (3SK87)
oscillator	BF970
mixer	1SS99
tuning diodes	3 x BB405B
surge protection diodes	2 x BAV10

Ambient temperature range

operating	0 to $+55^\circ\text{C}$
storage	-25 to $+70^\circ\text{C}$

Relative humidity

max. 95%

Voltages and currents

Supply voltage

$+12\text{ V} \pm 10\%$

Current drawn from $+12\text{ V}$ supply

bands I and III	max. 55 mA; typ. 44 mA
bands IV and V	max. 50 mA; typ. 40 mA

Bandswitching

For operation in all bands the supply voltage is permanently connected to terminal 6. Additionally the supply voltage is connected to:

- terminal 2 for operation in band I,
- terminal 3 for operation in band III,
- terminal 4 for operation in bands IV and V.

A.G.C. voltage (Figs 4, 5 and 6)

voltage range	$+9,2$ to $+0,85\text{ V}$
voltage at nominal gain	$+9,2 \pm 0,5\text{ V}$
voltage at 40 dB gain reduction	
band I	typ. 3 V
band III	typ. 1,5 V
voltage at 30 dB gain reduction	typ. 2 V

Note: A.G.C. voltages between 0 and $+10,5\text{ V}$ may be applied without risk of damage.

A.G.C. current

max. 0,3 mA

Slope of a.g.c. characteristic,

at the end of the specified a.g.c. range

bands I and III	typ. 25 dB/V
bands IV and V	typ. 50 dB/V

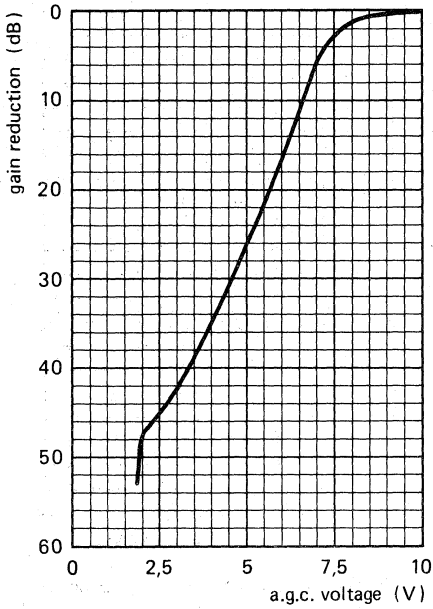

Fig. 4 Typical a.g.c. characteristic, band I.

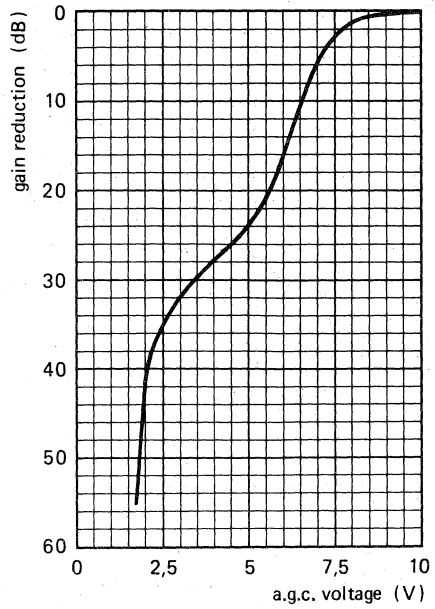

Fig. 5 Typical a.g.c. characteristic, band III.

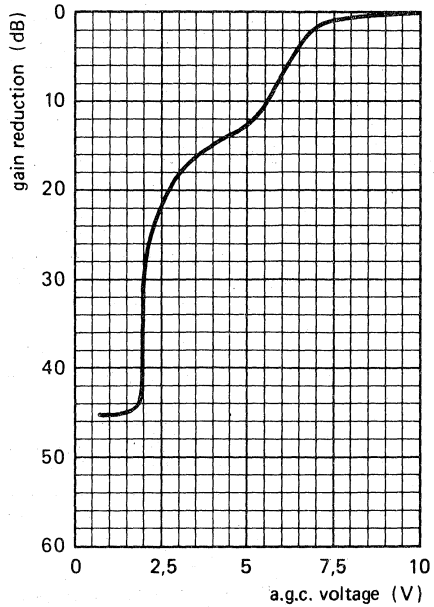

Fig. 6 Typical a.g.c. characteristic,
bands IV and V.

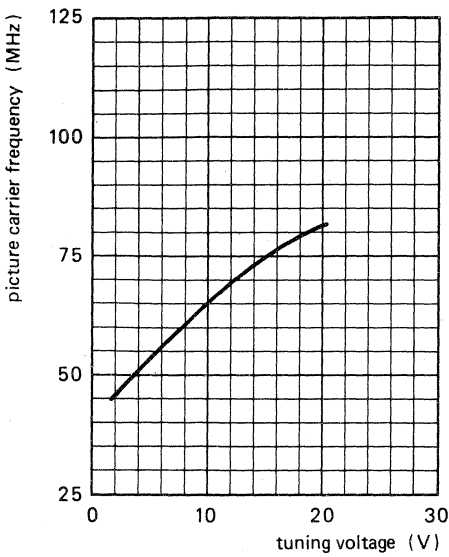

Fig. 7 Typical tuning characteristic, band I.

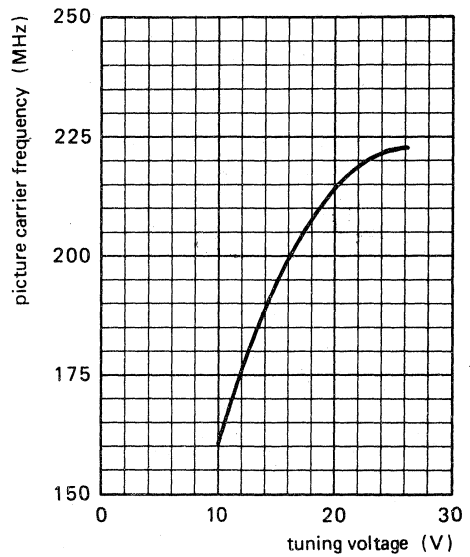

Fig. 8 Typical tuning characteristic, band III.

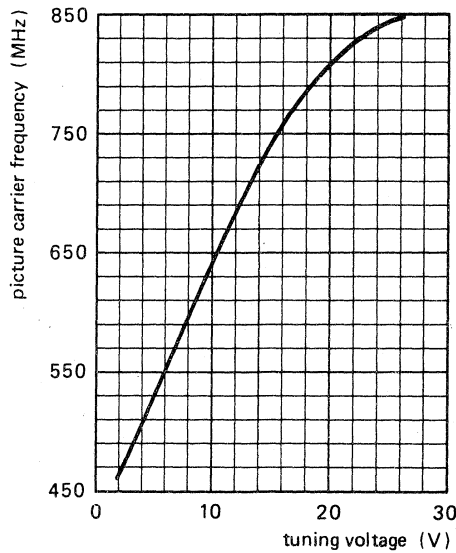

Fig. 9 Typical tuning characteristic, bands IV and V.

Tuning voltage range (Figs 7, 8 and 9) + 1 to + 28 V

Current drawn from 28 V tuning voltage supply

at $T_{amb} = 25\text{ }^{\circ}\text{C}$

max. $0,5\text{ }\mu\text{A}$

at $T_{amb} = 55\text{ }^{\circ}\text{C}$

max. $2\text{ }\mu\text{A}$

Note: The source impedance of the tuning voltage offered to terminal 7 must be maximum $47\text{ k}\Omega$.

Slope of tuning characteristic

band I, channel E2

3 MHz/V

channel E4

2 MHz/V

band III, channel E5

7 MHz/V

channel E12

2 MHz/V

bands IV and V, channel E21

22 MHz/V

channel E69

5 MHz/V

} typical values

Frequencies

Frequency ranges

band I

channel NZ1 (picture carrier 45,25 MHz) to

channel C (picture carrier 82,25 MHz).*

Margin at the extreme channels: min. 1,5 MHz.

band III

channel M4 (picture carrier 163,25 MHz) to

channel E12 (picture carrier 224,25 MHz).

Margin at the extreme channels: min. 2 MHz.

bands IV and V

channel E21 (picture carrier 471,25 MHz) to

channel E69 (picture carrier 855,25 MHz).

Margin at the extreme channels: min. 3 MHz.

Intermediate frequencies

picture

38,9 MHz

sound

33,4 MHz

The oscillator frequency is higher than the aerial signal frequency.

Wanted signal characteristics

Input impedance

$75\text{ }\Omega$

V.S.W.R. and reflection coefficient

(values between picture and sound carrier, as well as values at picture carrier)

v.s.w.r.

bands I and III

at nominal gain

during gain control

bands IV and V

max. 4,5

max. 5,5

reflection coefficient

max. 5

max. 7

bands I and III

max. 64%

max. 69%

bands IV and V

max. 66%

max. 75%

R.F. curves, bandwidth

band I

typ. 11 MHz

band III

typ. 13 MHz

bands IV and V

typ. 20 MHz

* Channel R4 (picture carrier 85,25 MHz) is within the frequency range, but not specified.

R.F. curves, tilt

on any channel the amplitude difference between the top of the r.f. resonant curve and the picture frequency, the sound frequency, or any frequency between them will not exceed 3 dB at nominal gain, and 4 dB in the a.g.c. range between nominal gain and 20 dB gain reduction.

A.G.C. range

bands I and III
bands IV and V

min. 40 dB
min. 30 dB

Power gain (see also Measuring method of power gain)

bands I and III
channel E3
channel E5
channel E12
bands IV and V
channel E21
channel E40
channel E69

min. 22 dB
typ. 28 dB
typ. 28 dB
typ. 28 dB
min. 20 dB
typ. 28 dB
typ. 27 dB
typ. 26 dB

Maximum gain difference

between any two v.h.f. channels
between any two u.h.f. channels
between any v.h.f. and u.h.f. channel

typ. 2 dB
typ. 3 dB
typ. 4 dB

Noise figure

bands I and III, except channels NZ1 and M4
channels NZ1 and M4
channel E3
channel E5
channel E12
bands IV and V
channel E21
channel E40
channel E69

max. 7 dB
max. 10 dB
typ. 4 dB
typ. 4 dB
typ. 5 dB
max. 10 dB
typ. 6 dB
typ. 6 dB
typ. 7 dB

Overloading

Input signal producing 1 dB gain

compression at nominal gain
bands I and III
bands IV and V

typ. 90 dB (μ V) into 75 Ω
typ. 90 dB (μ V) into 75 Ω

Input signal producing either a detuning

of the oscillator of + 300 kHz or
-1000 kHz or stopping of the
oscillations at nominal gain
bands I and III
bands IV and V

typ. 100 dB (μ V) into 75 Ω
typ. 100 dB (μ V) into 75 Ω

Unwanted signal characteristics

Image rejection (measured at picture carrier frequency)

bands I and III, except channels C and R4
channels C and R4
bands IV and V

min. 60 dB; typ. 70 dB
min. 55 dB
min. 44 dB; typ. 53 dB

I.F. rejection (measured at picture carrier frequency)	
channel NZ1	min. 40 dB
channel E2	min. 45 dB
channels E3 to C	min. 50 dB
band III	min. 60 dB
bands IV and V	min. 60 dB

Note: At colour sub-carrier frequency maximum 6 dB less rejection.

N \pm 4 rejection (for u.h.f. only)

Interference signal for an interference ratio of 53 dB referred to wanted picture carrier (picture to sound carrier ratio of 10 dB; wanted signal 60 dB (μ V); tuner operating at nominal gain) typ. 75 dB (μ V) into 75 Ω

Cross modulation

Input signal producing 1% cross modulation, i.e. 1% of the modulation depth of the interfering signal is transferred to the wanted signal.

In channel cross modulation (wanted signal: picture carrier frequency; interfering signal: sound carrier frequency)

bands I and III

at nominal gain (wanted input level 60 dB (μ V))	typ. 74 dB (μ V) into 75 Ω
at 40 dB gain reduction (wanted input level 100 dB (μ V))	typ. 94 dB (μ V) into 75 Ω

bands IV and V

at nominal gain (wanted input level 60 dB (μ V))	typ. 74 dB (μ V) into 75 Ω
at 30 dB gain reduction (wanted input level 90 dB (μ V))	typ. 94 dB (μ V) into 75 Ω

In band cross modulation (wanted signal: picture carrier of channel N; interfering signal: picture carrier of channel N \pm 2 for v.h.f. I, or channel N \pm 3 for v.h.f. III, or channel N \pm 5 for u.h.f.)

bands I and III

at nominal gain (wanted input level 60 dB (μ V))	typ. 82 dB (μ V) into 75 Ω
at 40 dB gain reduction (wanted input level 100 dB (μ V))	typ. 94 dB (μ V) into 75 Ω

bands IV and V

at nominal gain (wanted input level 60 dB (μ V))	typ. 82 dB (μ V) into 75 Ω
at 30 dB gain reduction (wanted input level 90 dB (μ V))	typ. 94 dB (μ V) into 75 Ω

Out of band cross modulation at nominal gain

v.h.f. I, interfering from v.h.f. III	typ. 94 dB (μ V) into 75 Ω
v.h.f. I, interfering from u.h.f.	typ. 90 dB (μ V) into 75 Ω
v.h.f. III, interfering from v.h.f. I	typ. 94 dB (μ V) into 75 Ω
v.h.f. III, interfering from u.h.f.	typ. 90 dB (μ V) into 75 Ω
u.h.f. interfering from v.h.f. I	typ. 94 dB (μ V) into 75 Ω
u.h.f. interfering from v.h.f. III	typ. 86 dB (μ V) into 75 Ω

Oscillator characteristics

Pulling

Input signal of tuned frequency producing a shift of the oscillator frequency of 10 kHz, at nominal gain

- bands I and III
- bands IV and V

typ. 80 dB (μ V) into 75 Ω
typ. 80 dB (μ V) into 75 Ω

Shift of oscillator frequency at a change of the supply voltage of 5%

- bands I and III
- bands IV and V

max. 200 kHz
max. 400 kHz

Drift of oscillator frequency

during warm-up time (after the tuner has been completely out of operation for 15 min, measured between 5 s and 15 min after switching on)

max. 250 kHz

during warm-up time (after the input stage is in operation for 15 min, measured between 2 s and 15 min after band switching)

max. 250 kHz

at a change of the ambient temperature from + 25 to + 40 °C (measured after 3 cycles from + 25 to + 55 °C)

- bands I and III
- bands IV and V

max. 300 kHz
max. 500 kHz

Frequency divider characteristics; only valid for UV412

Supply voltage

+ 5 V \pm 5%

Current drawn from + 5 V supply

- bands I and III
- bands IV and V

max. 45 mA; typ. 35 mA
max. 55 mA; typ. 45 mA

Output voltage

3,4 to 10 V, depending on load and supply voltage

Output current

- at output voltage 3,4 V
- at output voltage 5 V

min. 1 mA
max. 1,5 mA

Interference signal on the i.f. output

max. 3 μ V

Note: I.F. output of the tuner terminated with the circuit shown in Fig. 10

I.F. circuit characteristics

Bandwidth of i.f. output circuit

5 \pm 1 MHz

Note: I.F. output of the tuner terminated with the circuit shown in Fig. 10; tuning voltage 2 V; u.h.f. band switched on.

Bandwidth variation of i.f. output circuit as a result of r.f. tuning and band switching (reference: u.h.f.; tuning voltage 2 V)

max. 650 kHz

Note: I.F. output of the tuner terminated with a modified circuit of Fig. 10, i.e. a 100 pF capacitor is connected in parallel with the i.f. output of the tuner.

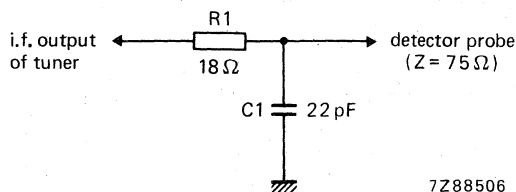

Fig. 10.

Detuning of the i.f. output circuit as a result of r.f. tuning and band switching (reference: u.h.f.; tuning voltage 2 V)

max. 500 kHz

Note: I.F. output of the tuner terminated with a modified circuit of Fig. 10, i.e. a 100 pF capacitor is connected in parallel with the i.f. output of the tuner.

Minimum tuning range of i.f. output coil

33 to 40 MHz

Note: I.F. output of the tuner terminated with the circuit shown in Fig. 10.

Attenuation between i.f. injection point and i.f. output of the tuner

typ. 16 dB

Miscellaneous

Radio interference
Oscillator radiation and oscillator voltage at the aerial terminal

Within the limits of C.I.S.P.R. 13 (1975) and VDE 0872/7.72.

Microphonics

There will be no microphonics, provided the tuner is installed in a professional manner.

Surge protection

Protection against voltages

max. 5 kV

Note: 10 discharges of a 470 pF capacitor into the aerial terminal.

Protection against flashes

max. 30 kV, 400 mWs

Note: A flashover circuit producing flashes with frequencies of 1 to 20 Hz for 30 s is connected to the aerial terminal.

ADDITIONAL INFORMATION

I.F. injection

Terminal 4 (supply voltage u.h.f.) can be used as i.f. injection point, provided the u.h.f. supply voltage is applied to terminal 4 via a resistor of $10\ \Omega$ (see Fig. 11). The u.h.f. band should be switched on; tuning voltage should be $2\ \text{V}$.

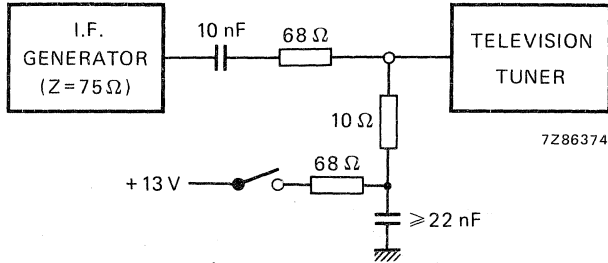

Fig. 11.

Connection of the i.f. amplifier

No special precautions are required to load and to match the i.f. output of the tuner.

Connection of supply voltages

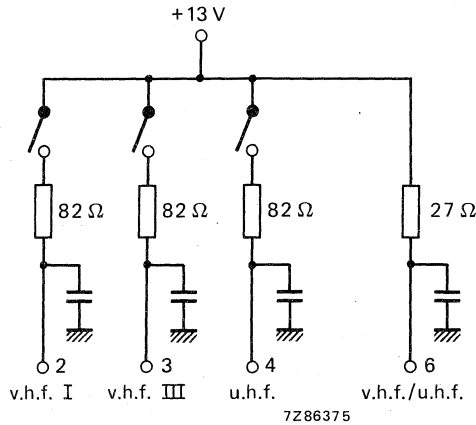

Fig. 12.

Measuring method of power gain

The i.f. output of the tuner should be terminated with the RC-circuit given in Fig. 10.

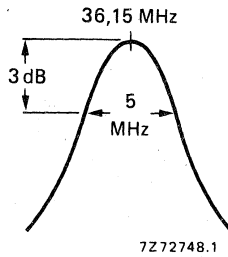

Fig. 13.

The RC-circuit roughly matches the i.f. output impedance to 75Ω at the resonant frequency of the i.f. output circuit, which should be tuned to 36,15 MHz; the bandwidth is approx. 5 MHz (Fig. 13).

Because the input and output impedances of the tuner are now 75Ω , the power gain can be measured in the conventional manner by inserting tuner and RC-circuit between a 75Ω source and a 75Ω detector.

Alignment of the i.f. output coil

The i.f. output coil should be adjusted with a brass tool with a blade as shown in Fig. 14. A suitable tool is available under catalogue number 7122 005 47680.

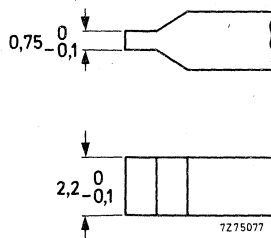

Fig. 14.

V.H.F./U.H.F. TELEVISION TUNERS

QUICK REFERENCE DATA

Systems	C.C.I.R. systems B and G
Channels	
v.h.f. I	E2 to E4
v.h.f. III	E5 to E12
u.h.f.	E21 to E60
Intermediate frequencies	
picture	38,9 MHz
sound	33,4 MHz

APPLICATION

Designed to cover the v.h.f. and u.h.f. channels of C.C.I.R. systems B and G, with extended v.h.f. frequency ranges.

The tuners comply with the requirements of radiation, signal handling capability, and immunity from radiated interference of Amtsblatt DBP69/1981.

Tuner UV414 is equipped with a frequency divider, which makes this type suitable for digital tuning systems based on frequency synthesis; for the remainder it is equal to type UV413.



DESCRIPTION

The UV413 and UV414 are combined v.h.f./u.h.f. tuners with electronic tuning and band switching, covering the v.h.f. band I (frequency range 47 to 68 MHz), the v.h.f. band III including the Morocco channel M4 (frequency range 162 to 230 MHz), and the u.h.f. band (frequency range 470 to 790 MHz).

Mechanically, the tuners are built on a low-loss printed-wiring board, carrying all components, in a metal housing made of a rectangular frame and front and rear covers (see Fig. 2). The common aerial connection (v.h.f. and u.h.f.) is on one of the frame sides, all other connections (supply voltages, a.g.c. voltage, tuning and switching voltages, i.f. output) are made via feed-through capacitors in the underside. The mounting method is shown in Fig. 3.

Electrically, the tuners consist of v.h.f. and u.h.f. parts. The v.h.f. aerial signal is fed via switchable v.h.f. band I/III wide band input filters to gate 1 of an input MOSFET tetrode (with internal gate protection against surge).

The input filters are provided with an i.f. and f.m. suppression circuit. The drain load of the MOSFET tetrode is formed by a double tuned switchable bandpass filter, transferring the r.f. signal to the emitter of the mixer transistor. The oscillator signal is also fed to the emitter of the mixer transistor.

The collector circuit of the mixer transistor is a single tuned i.f. resonant circuit, at the low end of which the i.f. signal is coupled out of the tuner. A test point (terminal 4) is provided for i.f. injection to align the i.f. output circuit of the tuner together with the i.f. amplifier of the television receiver. An additional test point, which is accessible through a hole in the top of the tuner, is connected to the collector of the mixer transistor.

The r.f. band pass filter and oscillator circuits are tuned by 3 tuning diodes; band switching is achieved by 5 switching diodes.

The u.h.f. part of the tuner consists of a tuned input circuit connected to gate 1 of an input MOSFET tetrode (with internal gate protection against surge). The drain load of this MOSFET tetrode is formed by a double tuned circuit transferring the r.f. signal to the Schottky barrier mixer diode.

The i.f. signal from the mixer diode is amplified by the v.h.f. mixer transistor, now operating as an i.f. amplifier.

The input, r.f. band pass filter and oscillator circuits are tuned by 4 tuning diodes.

In all bands the tuner is gain controlled via gate 2 of the input MOSFET tetrode.

The electrical circuit of the UV414 is extended with a frequency divider SAB1077 (division ratio of 256), which inputs are connected to the v.h.f. and u.h.f. oscillator. The outputs are complementary open-collector current sources; they are connected to terminals 12 and 13. The output voltage is determined by the external load and the supply voltage, which is connected to this load. They should be chosen such that:

- the output-voltage rating of 10 V is not exceeded;
- the output voltage does not drop more than 1,6 V below 5 V (supply voltage of frequency divider);
- the output-voltage swing does not exceed 1 V.

Radiation by the output signal may be reduced by transporting the two complementary signals via twisted wires or a flat cable, even if only one signal is to be used to drive the subsequent circuit.

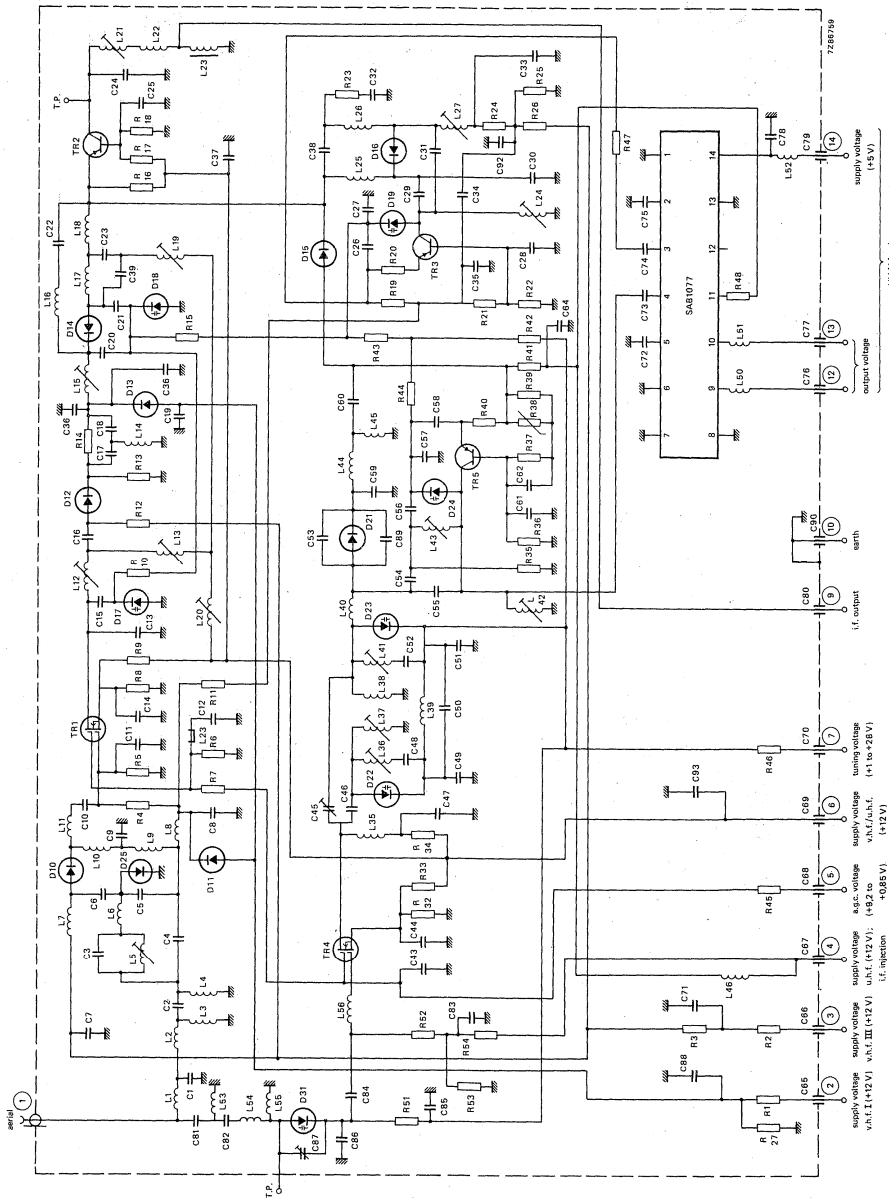

Fig. 1.



MECHANICAL DATA

Dimensions in mm

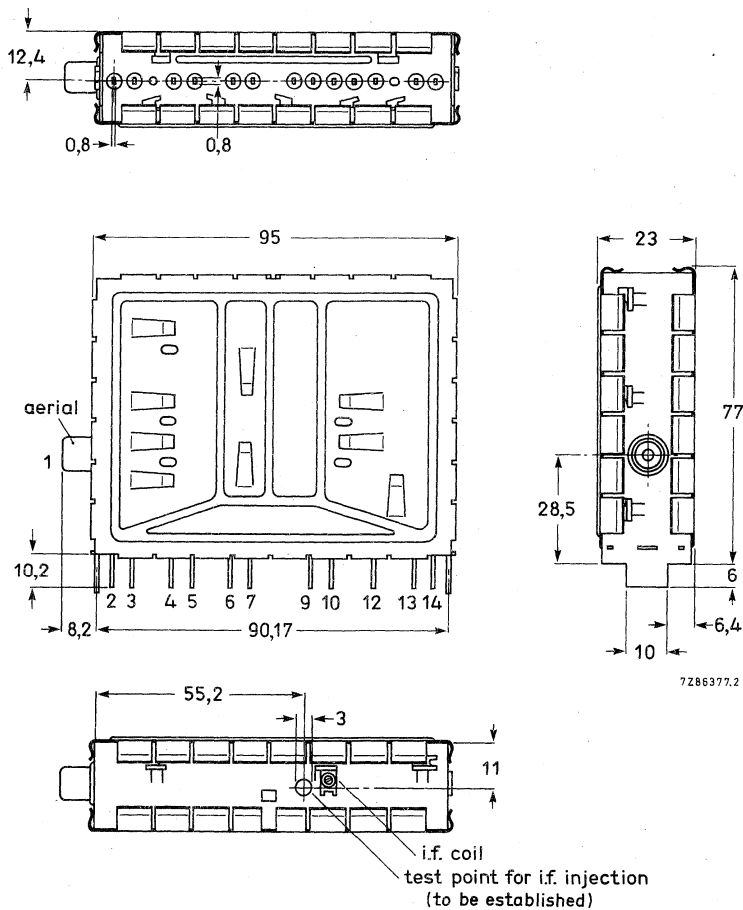

Fig. 2a.

- | | | |
|------------|--|------------------|
| Terminal 1 | = aerial | |
| 2 | = supply voltage, v.h.f. I, + 12 V | |
| 3 | = supply voltage, v.h.f. III, + 12 V | |
| 4 | = supply voltage, u.h.f., + 12 V; i.f. injection | |
| 5 | = a.g.c. voltage, + 9,2 to + 0,85 V | |
| 6 | = supply voltage, v.h.f. and u.h.f., + 12 V | |
| 7 | = tuning voltage, + 1 to + 28 V | |
| 9 | = i.f. output | |
| 10 | = earth | |
| 12,13 | = balanced output voltage of frequency divider | } only for UV414 |
| 14 | = supply voltage, frequency divider, + 5 V | |

Fig. 2b I.F. output coil.

Torque for alignment: 2 to 15 mNm.
Press-through force: ≥ 10 N.

Mass approx. 127 g

Mounting

The tuner may be mounted by soldering it on to a printed-wiring board, using the piercing diagram shown in Fig. 3. (The tuner may also be mounted by means of a bracket. Information will be supplied upon request.) The tuner may be mounted anywhere in the receiver and there are no restrictions on orientation.

The solderability of the terminals and mounting tabs is according to IEC 68-2, test Ta ($230 \pm 10 \text{ }^\circ\text{C}$, $2 \pm 0,5 \text{ s}$). The resistance to soldering heat is according to IEC 68-2, test Tb ($260 \pm 5 \text{ }^\circ\text{C}$, $10 \pm 1 \text{ s}$).

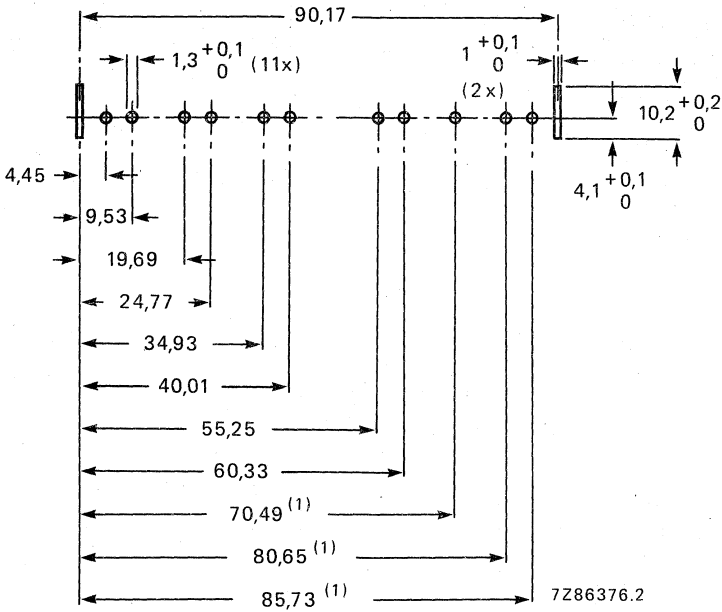

(1) Only for UV414.

Fig. 3 Piercing diagram viewed from solder side of board. Unless otherwise stated the tolerance is $\pm 0,05 \text{ mm}$.

ELECTRICAL DATA

Unless otherwise specified all electrical values apply at an ambient temperature of $25 \pm 5 \text{ }^\circ\text{C}$, a relative humidity of $60 \pm 15\%$, a supply voltage of $12 \pm 0,3 \text{ V}$ and an a.g.c. voltage of $9,2 \pm 0,2 \text{ V}$.

General

Semiconductors, bands I and III

r.f. amplifier	BF982
mixer	BF324
oscillator	BF926
tuning diodes	3 x BB809
switching diodes	5 x BA482/483/484
d.c. blocking diodes	2 x BAW62

Semiconductors, bands IV and V

r.f. amplifier	BF980 (3SK87)
oscillator	BF970
mixer	1SS99
tuning diodes	4 x BB405B
surge protection diode	BAV10

Ambient temperature range

operating	0 to + 55 $^\circ\text{C}$
storage	-25 to + 70 $^\circ\text{C}$

Relative humidity

max. 95%

Voltages and currents

Supply voltage + 12 V \pm 10%

Current drawn from + 12 V supply

bands I and III	max. 55 mA; typ. 44 mA
bands IV and V	max. 50 mA; typ. 40 mA

Bandswitching

For operation in all bands the supply voltage is permanently connected to terminal 6. Additionally the supply voltage is connected to:

- terminal 2 for operation in band I,
- terminal 3 for operation in band III,
- terminal 4 for operation in bands IV and V.

A.G.C. voltage (Figs 4, 5 and 6)

voltage range	+ 9,2 to + 0,85 V
voltage at nominal gain	+ 9,2 \pm 0,5 V
voltage at 40 dB gain reduction	
band I	typ. 3 V
band III	typ. 1,5 V
voltage at 30 dB gain reduction	typ. 2 V

Note: A.G.C. voltages between 0 and + 10,5 V may be applied without risk of damage.

A.G.C. current

max. 0,3 mA

Slope of a.g.c. characteristic,

at the end of the specified a.g.c. range

bands I and III	typ. 25 dB/V
bands IV and V	typ. 50 dB/V

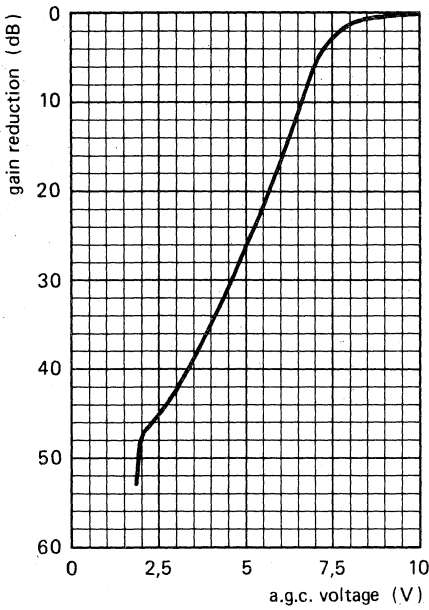

Fig. 4 Typical a.g.c. characteristic, band I.

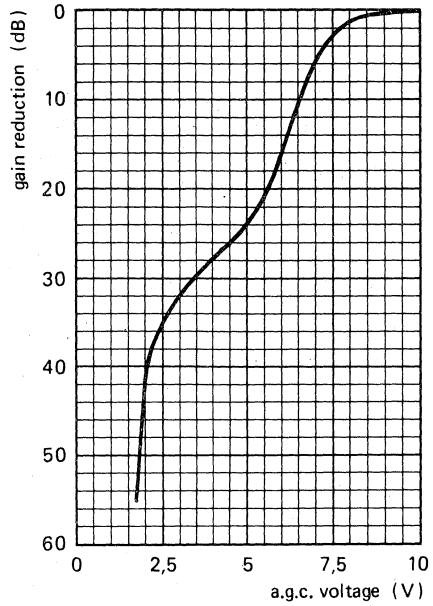
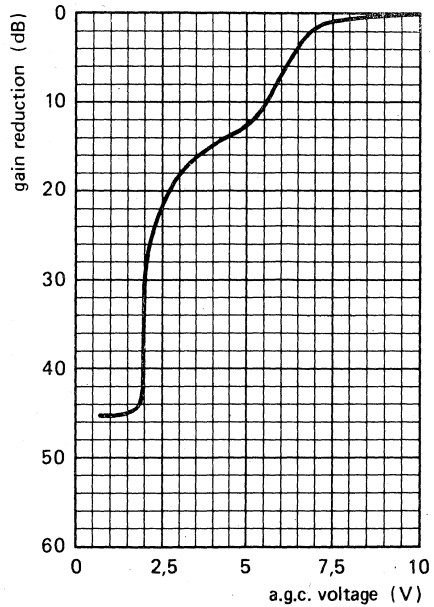

Fig. 5 Typical a.g.c. characteristic, band III.

Fig. 6 Typical a.g.c. characteristic,
bands IV and V.



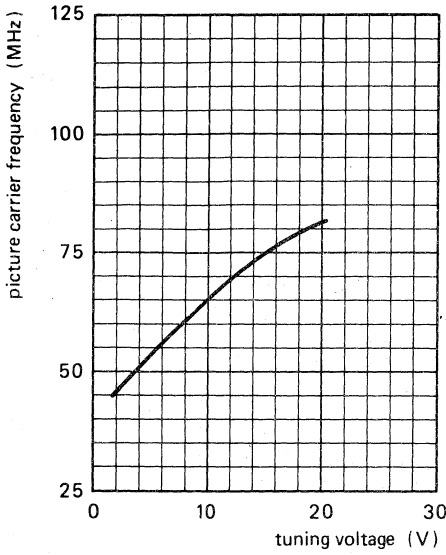

Fig. 7 Typical tuning characteristic, band I.

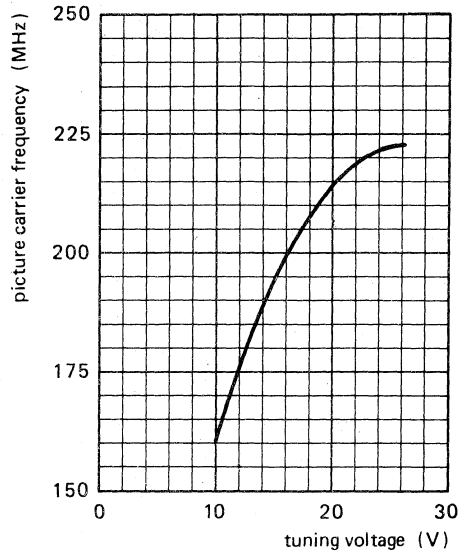

Fig. 8 Typical tuning characteristic, band III.

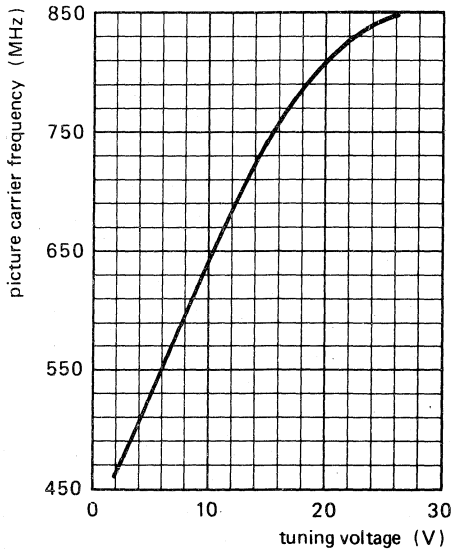

Fig. 9 Typical tuning characteristic, bands IV and V.

Tuning voltage range (Figs 7, 8 and 9) + 1 to + 28 V
 Current drawn from 28 V tuning voltage supply
 at $T_{amb} = 25\text{ }^{\circ}\text{C}$ max. 0,5 μA
 at $T_{amb} = 55\text{ }^{\circ}\text{C}$ max. 2 μA

Note: The source impedance of the tuning voltage offered to terminal 7 must be maximum 47 k Ω .

Slope of tuning characteristic

band I, channel E2	3 MHz/V	} typical values
channel E4	2 MHz/V	
band III, channel E5	7 MHz/V	
channel E12	2 MHz/V	
bands IV and V, channel E21	22 MHz/V	
channel E60	16 MHz/V	

Frequencies

Frequency ranges

band I	channel E2 (picture carrier 48,25 MHz) to channel E4 (picture carrier 62,25 MHz). Margin at the extreme channels: min. 1,5 MHz.
band III	channel E5 (picture carrier 175,25 MHz) to channel E12 (picture carrier 224,25 MHz). Margin at the extreme channels: min. 2 MHz.
bands IV and V	channel E21 (picture carrier 471,25 MHz) to channel E60 (picture carrier 783,25 MHz). Margin at the extreme channels: min. 3 MHz.

Intermediate frequencies

picture	38,9 MHz
sound	33,4 MHz

The oscillator frequency is higher than the aerial signal frequency.

Wanted signal characteristics

Input impedance 75 Ω

V.S.W.R. and reflection coefficient
 (values between picture and sound carrier,
 as well as values at picture carrier)

v.s.w.r.	at nominal gain	during gain control
bands I and III	max. 4,5	max. 5,5
bands IV and V	max. 5	max. 7
reflection coefficient		
bands I and III	max. 63%	max. 69%
bands IV and V	max. 66%	max. 75%

R.F. curves, bandwidth

band I	typ. 11 MHz
band III	typ. 13 MHz
bands IV and V	typ. 20 MHz

R.F. curves, tilt

on any channel the amplitude difference between the top of the r.f. resonant curve and the picture frequency, the sound frequency, or any frequency between them will not exceed 3 dB at nominal gain, and 4 dB in the a.g.c. range between nominal gain and 20 dB gain reduction.

A.G.C. range

bands I and III
bands IV and V

min. 40 dB
min. 30 dB

Power gain (see also Measuring method of power gain)

bands I and III
channel E3
channel E5
channel E12
bands IV and V
channel E21
channel E40
channel E69

min. 20 dB
typ. 24 dB
typ. 23 dB
typ. 22 dB
min. 16 dB
typ. 23 dB
typ. 19 dB
typ. 22 dB

Maximum gain difference

between any two v.h.f. channels
between any two u.h.f. channels
between any v.h.f. and u.h.f. channel

typ. 3 dB
typ. 4 dB
typ. 6 dB

Noise figure

bands I and III
channel E3
channel E5
channel E12
bands IV and V
channel E21
channel E40
channel E69

max. 8 dB
typ. 5,5 dB
typ. 5 dB
typ. 6,5 dB
max. 13 dB
typ. 8,5 dB
typ. 10 dB
typ. 9 dB

Overloading

Input signal producing 1 dB gain compression at nominal gain
bands I and III
bands IV and V

typ. 90 dB (μ V) into 75 Ω
typ. 90 dB (μ V) into 75 Ω

Input signal producing either a detuning of the oscillator of + 300 kHz or -1000 kHz or stopping of the oscillations at nominal gain
bands I and III
bands IV and V

typ. 100 dB (μ V) into 75 Ω
typ. 100 dB (μ V) into 75 Ω

Unwanted signal characteristics

Image rejection (measured at picture carrier frequency)
bands I and III
bands IV and V

min. 60 dB; typ. 70 dB
min. 50 dB; typ. 62 dB

I.F. rejection (measured at picture

carrier frequency)
channel E2
channels E3 to E4
band III
bands IV and V

min. 45 dB
min. 50 dB
min. 60 dB
min. 60 dB

Note: At colour sub-carrier frequency maximum 6 dB less rejection.

N ± 4 rejection (for u.h.f. only)

Interference signal for an interference
ratio of 53 dB referred to wanted picture
carrier (picture to sound carrier ratio
of 10 dB; wanted signal 60 dB (μV); tuner
operating at nominal gain)

N + 4 typ. 84 dB/μV into 75 Ω
N - 4 typ. 76 dB/μV into 75 Ω

Cross modulation

Input signal producing 1% cross modulation, i.e. 1% of the modulation depth of the interfering signal is transferred to the wanted signal.

In channel cross modulation (wanted signal: picture carrier frequency; interfering signal: sound carrier frequency)

bands I and III

at nominal gain (wanted input level 60 dB (μV)) typ. 84 dB (μV) into 75 Ω
at 40 dB gain reduction (wanted input level 100 dB (μV)) typ. 100 dB (μV) into 75 Ω

bands IV and V

at nominal gain (wanted input level 60 dB (μV)) typ. 84 dB (μV) into 75 Ω
at 30 dB gain reduction (wanted input level 90 dB (μV)) typ. 100 dB (μV) into 75 Ω

In band cross modulation (wanted signal: picture carrier of channel N; interfering signal: picture carrier of channel N ± 2 for v.h.f. I, or channel N ± 3 for v.h.f. III, or channel N ± 5 for u.h.f.)

bands I and III

at nominal gain (wanted input level 60 dB (μV)) typ. 92 dB (μV) into 75 Ω
at 40 dB gain reduction (wanted input level 100 dB (μV)) typ. 100 dB (μV) into 75 Ω

bands IV and V

at nominal gain (wanted input level 60 dB (μV)) typ. 92 dB (μV) into 75 Ω
at 30 dB gain reduction (wanted input level 90 dB (μV)) typ. 100 dB (μV) into 75 Ω

Out of band cross modulation at nominal gain

v.h.f. I, interfering from v.h.f. III typ. 100 dB (μV) into 75 Ω
v.h.f. I, interfering from u.h.f. typ. 100 dB (μV) into 75 Ω

v.h.f. III, interfering from v.h.f. I typ. 100 dB (μV) into 75 Ω
v.h.f. III, interfering from u.h.f. typ. 100 dB (μV) into 75 Ω

u.h.f., interfering from v.h.f. I typ. 100 dB (μV) into 75 Ω
u.h.f., interfering from v.h.f. III typ. 100 dB (μV) into 75 Ω

Unwanted signal handling capability (visibility test)

for channel combinations
v.h.f.: N ± 1, N ± 5, N + 11
u.h.f.: N ± 1, N ± 5, N + 9

according to the requirements
of Amtsblatt DBP69/1981,
item 5.1.2.

Oscillator characteristics

Pulling

Input signal of tuned frequency producing a shift of the oscillator frequency of 10 kHz, at nominal gain

bands I and III
bands IV and V

typ. 85 dB (μ V) into 75 Ω
typ. 85 dB (μ V) into 75 Ω

Shift of oscillator frequency at a change of the supply voltage of 5%

bands I and III
bands IV and V

max. 200 kHz
max. 400 kHz

Drift of oscillator frequency

during warm-up time (after the tuner has been completely out of operation for 15 min, measured between 5 s and 15 min after switching on)

max. 250 kHz

during warm-up time (after the input stage is in operation for 15 min, measured between 2 s and 15 min after band switching)

max. 250 kHz

at a change of the ambient temperature from + 25 to + 40 °C (measured after 3 cycles from + 25 to + 55 °C)

bands I and III
bands IV and V

max. 300 kHz
max. 500 kHz

Frequency divider characteristics; only valid for UV414

Supply voltage

+ 5 V \pm 5%

Current drawn from + 5 V supply

bands I and III
bands IV and V

max. 45 mA; typ. 35 mA
max. 55 mA; typ. 45 mA

Output voltage

3,4 to 10 V, depending on load and supply voltage

Output current

at output voltage 3,4 V
at output voltage 5 V

min. 1 mA
max. 1,5 mA

Interference signal on the i.f. output

max. 3 μ V

Note: I.F. output of the tuner terminated with the circuit shown in Fig. 10

I.F. circuit characteristics

Bandwidth of the i.f. output circuit

5 \pm 1 MHz

Note: I.F. output of the tuner terminated with the circuit shown in Fig. 10; tuning voltage 25 V; u.h.f. band switched on.

Bandwidth variation of i.f. output circuit as a result of r.f. tuning and band switching (reference: u.h.f.; tuning voltage 25 V)

max. 650 kHz

Note: I.F. output of the tuner terminated with a modified circuit of Fig. 10, i.e. a 100 pF capacitor is connected in parallel with the i.f. output of the tuner.

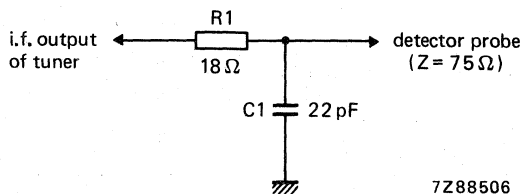

Fig. 10.

Detuning of the i.f. output circuit as a result of r.f. tuning and band switching (reference: u.h.f.; tuning voltage 25 V)

max. 500 kHz

Note: I.F. output of the tuner terminated with a modified circuit of Fig. 10, i.e. a 100 pF capacitor is connected in parallel with the i.f. output of the tuner.

Minimum tuning range of i.f. output coil

33 to 40 MHz

Note: I.F. output of the tuner terminated with the circuit shown in Fig. 10.

Attenuation between i.f. injection point and i.f. output of the tuner

typ. 16 dB

Miscellaneous

Radio interference

Oscillator radiation and oscillator voltage at the aerial terminal

within the limits of C.I.S.P.R. 13 (1975), VDE 0872/7.72 and Amtsblatt DBP69/1981.

Immunity from radiated interference

aerial input terminal meets the requirements of Amtsblatt DBP69/1981, item 5.3.2.

Microphonics

there will be no microphonics, provided the tuner is installed in a professional manner.

Surge protection

Protection against voltages

max. 5 kV

Note: 10 discharges of a 470 pF capacitor into the aerial terminal.

Protection against flashes

max. 30 kV, 400 mWs

Note: A flashover circuit producing flashes with frequencies of 1 to 20 Hz for 30 s is connected to the aerial terminal.

ADDITIONAL INFORMATION

I.F. injection

Terminal 4 (supply voltage u.h.f.) can be used as i.f. injection point, provided the u.h.f. supply voltage is applied to terminal 4 via a resistor of $10\ \Omega$ (see Fig. 11). The u.h.f. band should be switched on; tuning voltage should be $2\ \text{V}$.

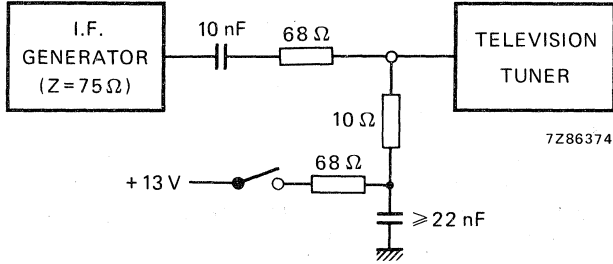

Fig. 11.

Connection of the i.f. amplifier

No special precautions are required to load and to match the i.f. output of the tuner.

Connection of supply voltages

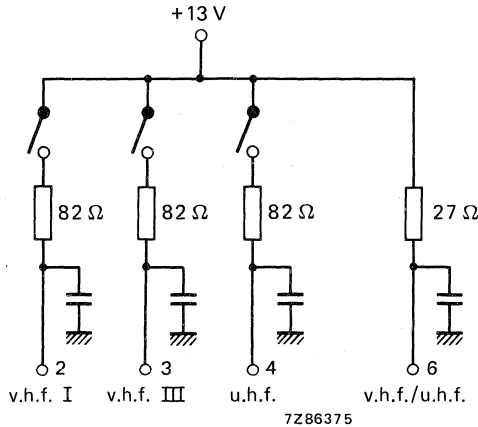

Fig. 12.

Measuring method of power gain

The i.f. output of the tuner should be terminated with the RC-circuit given in Fig. 10.

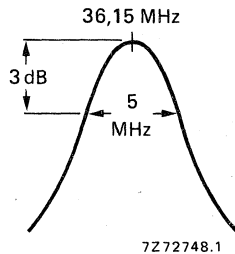

Fig. 13.

The RC-circuit roughly matches the i.f. output impedance to 75Ω at the resonant frequency of the i.f. output circuit, which should be tuned to 36,15 MHz; the bandwidth is approx. 5 MHz (Fig. 13).

Because the input and output impedances of the tuner are now 75Ω , the power gain can be measured in the conventional manner by inserting tuner and RC-circuit between a 75Ω source and a 75Ω detector.

Alignment of the i.f. output coil

The i.f. output coil should be adjusted with a brass tool with a blade as shown in Fig. 14. A suitable tool is available under catalogue number 7122 005 47680.

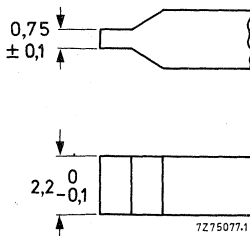

Fig. 14.

V.H.F./U.H.F. TELEVISION TUNERS

QUICK REFERENCE DATA

Systems	C.C.I.R. systems B and G
Channels	
low v.h.f.	E2 to S1
high v.h.f.	S2 to S19
u.h.f.	E21 to E69
Intermediate frequencies	
picture	38,9 MHz
sound	33,4 MHz

APPLICATION

To cover the v.h.f. and u.h.f. channels of C.C.I.R. systems B and G, including the S channels for cable television.

Tuner UV416 has a frequency divider, which makes it suitable for digital tuning systems based on frequency synthesis; it is otherwise the same as type UV415.

Tuners UV415 and UV416 are pin-compatible with UV411 and UV412 respectively.



DESCRIPTION

The UV415 and UV416 are combined v.h.f./u.h.f. tuners with electronic tuning and bandswitching, covering the low v.h.f. band (frequency range 47 to 111 MHz), high v.h.f. band (frequency range 111 to 293 MHz) and u.h.f. band (frequency range 470 to 861 MHz).

The tuners are built on a low-loss printed-wiring board, carrying all components, in a metal housing made of a rectangular frame and front and rear covers (see Fig. 2). The common aerial connection (v.h.f. and u.h.f.) is on one of the frame sides, all other connections (supply voltages, a.g.c. voltage, tuning and switching voltages, i.f. output) are made via terminals in the underside. The mounting method is shown in Fig. 3.

The tuners consist of v.h.f. and u.h.f. parts. The v.h.f. aerial signal is fed via a tuned input circuit, switchable between the low and high v.h.f. bands, to gate 1 of an input MOSFET tetrode (with internal gate protection against surge). Additional i.f. and i.f. rejection is incorporated in the input circuit. The drain load of the MOSFET tetrode is a double tuned switchable bandpass filter, transferring the r.f. signal to the emitter of the mixer transistor. The oscillator signal is also fed to the emitter of the mixer transistor.

The collector circuit of the mixer transistor is a single tuned i.f. resonant circuit, at the low end of which the i.f. signal is coupled out of the tuner. A test point (terminal 4) allows i.f. injection to align the i.f. output circuit of the tuner with the i.f. amplifier of the television receiver.

An additional test point, which is accessible through a hole in the top of the tuner, is connected to the collector of the mixer transistor.

The r.f. band pass filter and oscillator circuits are tuned by 6 tuning diodes; band switching is achieved by 6 switching diodes.

The u.h.f. part of the tuner has a high-pass input circuit connected to gate 1 of an input MOSFET tetrode (with internal gate protection against surge). The drain load of this MOSFET tetrode is formed by a double tuned circuit transferring the r.f. signal to the Schottky barrier mixer diode.

The i.f. signal from the mixer diode is amplified by the v.h.f. mixer transistor, which operates as an i.f. amplifier.

The r.f. band pass filter and oscillator circuits are tuned by 3 tuning diodes.

In all bands the tuner is gain controlled via gate 2 of the input MOSFET tetrode.

The circuit of the UV416 is extended with a frequency divider SAB1077 (division ratio of 256), with inputs connected to the v.h.f. and u.h.f. oscillator. The outputs are complementary open-collector current sources connected to terminals 12 and 13. The output voltage is determined by the external load and the supply voltage, which is connected to this load. They should be such that:

- the output-voltage rating of 10 V is not exceeded;
- the output voltage does not drop more than 1,6 V below 5 V (supply voltage of frequency divider);
- the output-voltage swing does not exceed 1 V.

Radiation of the output signal may be reduced by feeding the two complementary signals via twisted wires or a flat cable, even if only one signal is to be used to drive the subsequent circuit.

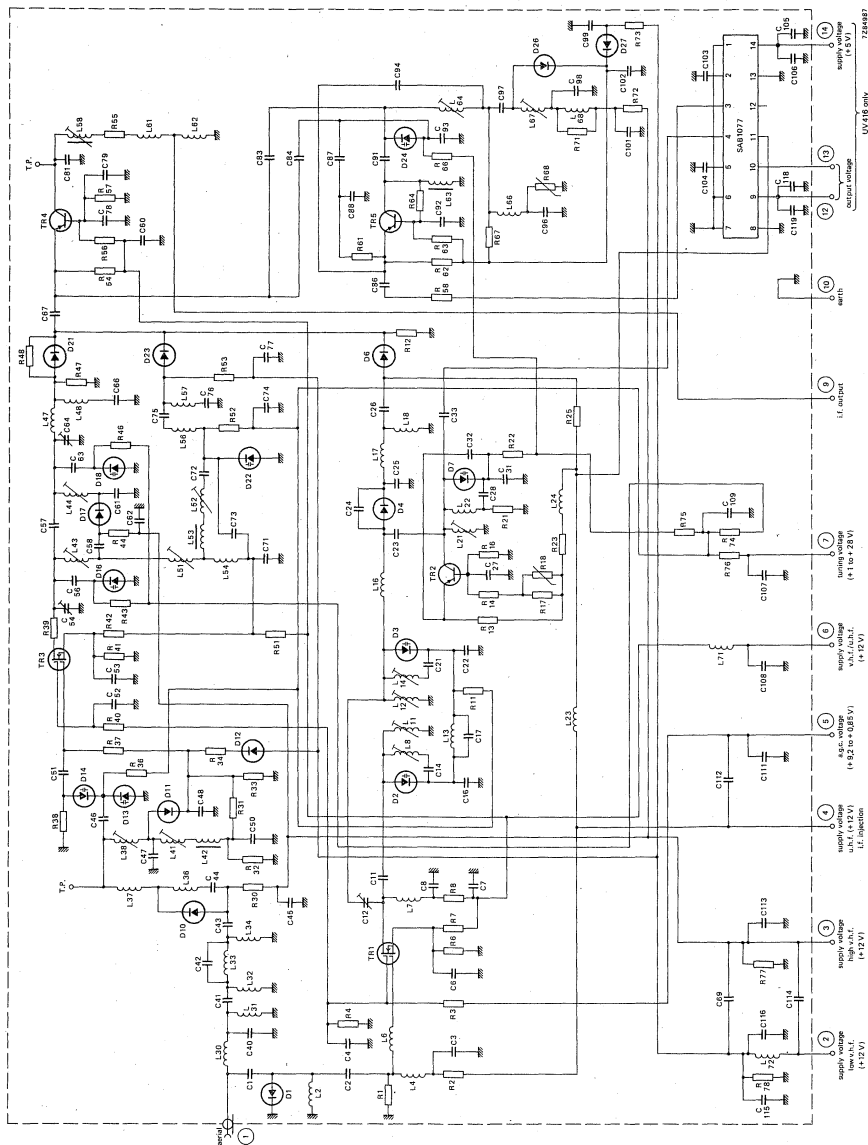

MECHANICAL DATA

Dimensions in mm

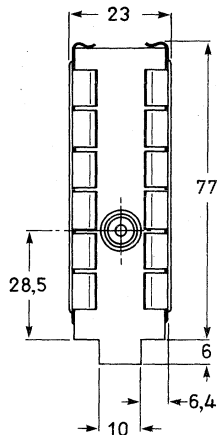
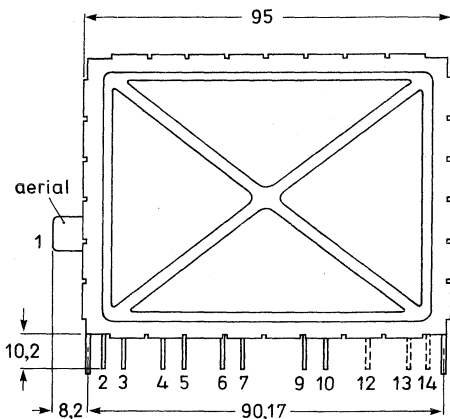
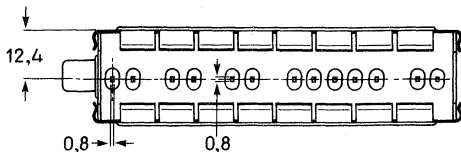

7286524

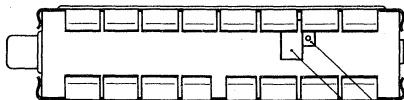

test point for i.f. injection
i.f. coil

Fig. 2a.

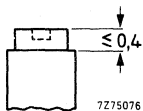

Fig. 2b I.F. output coil.

Torque for alignment: 2 to 20 mNm.
Press-through force: ≥ 10 N.

Terminal 1	= aerial	
2	= supply voltage, low v.h.f., + 12 V	
3	= supply voltage, high v.h.f., + 12 V	
4	= supply voltage, u.h.f., + 12 V; i.f. injection	
5	= a.g.c. voltage, + 9,2 to 0,85 V	
6	= supply voltage, v.h.f. and u.h.f., + 12 V	
7	= tuning voltage, + 1 to + 28 V	
9	= i.f. output	
10	= earth	
12,13	= balanced output voltage of frequency divider	only for
14	= supply voltage, frequency divider, + 5 V	UV416

Mass approx. 127 g

Mounting

The tuner may be mounted by soldering it on to a printed-wiring board, using the piercing diagram shown in Fig. 3. (The tuner may also be mounted by means of a bracket. Information will be supplied upon request.) The tuner may be mounted anywhere in the receiver and there are no restrictions on orientation.

The solderability of the terminals and mounting tabs is according to IEC68-2, test Ta ($230 \pm 10 \text{ }^\circ\text{C}$, $2 \pm 0,5 \text{ s}$). The resistance to soldering heat is according to IEC68-2, test Tb ($260 \pm 5 \text{ }^\circ\text{C}$, $10 \pm 1 \text{ s}$).

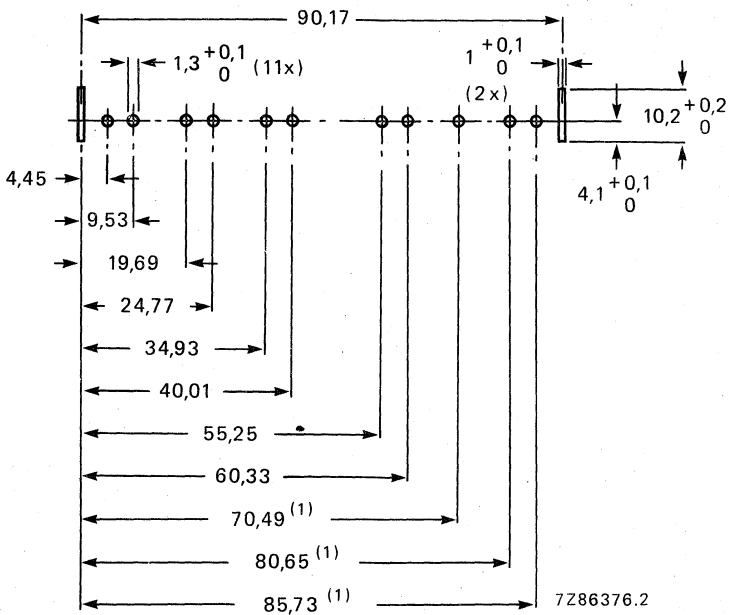

(1) Only for UV416.

Fig. 3 Piercing diagram viewed from solder side of board. Unless otherwise stated the tolerance is $\pm 0,05 \text{ mm}$.

ELECTRICAL DATA

Unless otherwise specified all electrical values apply at an ambient temperature of 25 ± 5 °C, a relative humidity of $60 \pm 15\%$, a supply voltage of $12 \pm 0,3$ V and an a.g.c. voltage of $9,2 \pm 0,2$ V.

General

Semiconductors, v.h.f.

r.f. amplifier	BF980
mixer	BF324
oscillator	BF606A
tuning diodes	6 x BB909
switching diodes	6 x BA482/483
d.c. blocking diodes	2 x BA317

Semiconductors, u.h.f.

r.f. amplifier	BF980 (3SK87)
oscillator	BF970
mixer	1SS99
tuning diodes	3 x BB405B
switching diode	BA483
surge protection diodes	BAV10

Ambient temperature range

operating	0 to + 55 °C
storage	-25 to + 70 °C

Relative humidity

max. 95%

Voltages and currents

Supply voltage

+ 12 V \pm 10%

Current drawn from + 12 V supply

low v.h.f.	max. 50 mA; typ. 32 mA
high v.h.f.	max. 50 mA; typ. 28 mA
u.h.f.	max. 50 mA; typ. 30 mA

Bandswitching

For operation in all bands the supply voltage is permanently connected to terminal 6. Additionally the supply voltage is connected to:

- terminal 2 for low v.h.f. operation,
- terminal 3 for high v.h.f. operation,
- terminal 4 for u.h.f. operation.

A.G.C. voltage (Figs 4, 5 and 6)

voltage range	+ 9,2 to + 0,85 V
voltage at nominal gain	+ 9,2 \pm 0,5 V
voltage at 40 dB gain reduction	
low v.h.f.	typ. 3,5 V
high v.h.f.	typ. 1,5 V
voltage at 30 dB gain reduction, u.h.f.	typ. 2 V

Note: A.G.C. voltages between 0 and + 10,5 V may be applied without risk of damage.

A.G.C. current

max. 0,3 mA

Slope of a.g.c. characteristic,

at the end of the specified a.g.c. range	
v.h.f.	typ. 40 dB/V
u.h.f.	typ. 80 dB/V

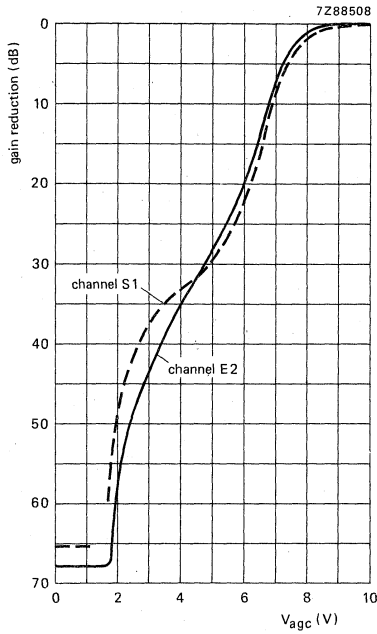

Fig. 4 Typical a.g.c. characteristic, low v.h.f.

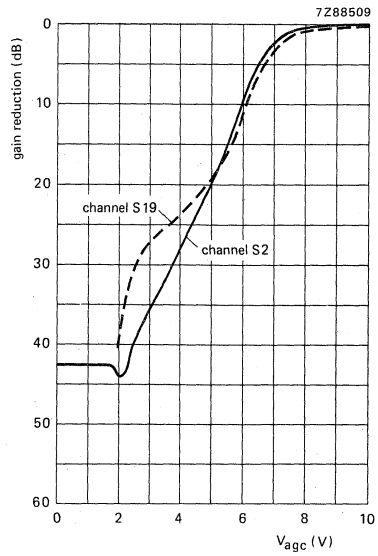

Fig. 5 Typical a.g.c. characteristic, high v.h.f.

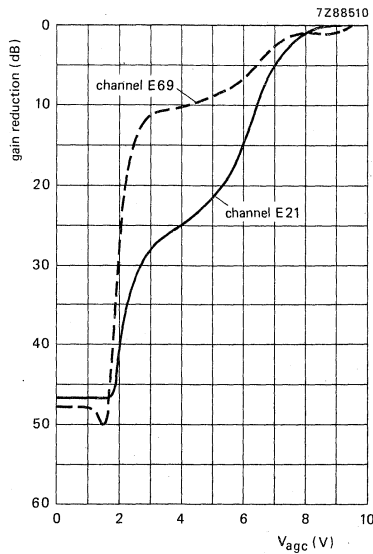

Fig. 6 Typical a.g.c. characteristic, u.h.f.

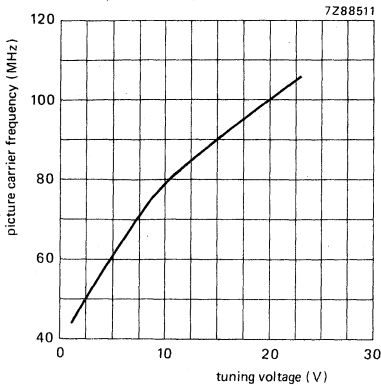

Fig. 7 Typical tuning characteristic, low v.h.f.

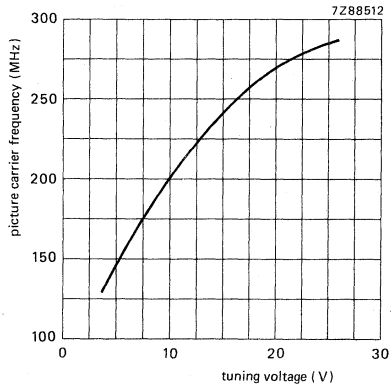

Fig. 8 Typical tuning characteristic, high v.h.f.

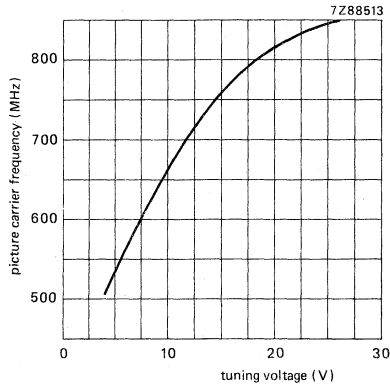

Fig. 9 Typical tuning characteristic, u.h.f.

Tuning voltage range (Figs 7, 8 and 9) + 1 to + 28 V

Current drawn from 28 V tuning voltage supply

at $T_{amb} = 25^{\circ}\text{C}$, R.H. = 60%

max. 0,5 μA

at $T_{amb} = 55^{\circ}\text{C}$, R.H. = 60%

max. 2 μA

at $T_{amb} = 25^{\circ}\text{C}$, R.H. = 95%

max. 2 μA

Note: The source impedance of the tuning voltage connected to terminal 7 must be maximum 47 k Ω .

Slope of tuning characteristic

low v.h.f., channel E2

5 MHz/V

channel S1

1 MHz/V

high v.h.f., channel E5

11 MHz/V

channel S19

2 MHz/V

u.h.f., channel E21

22 MHz/V

channel E69

3 MHz/V

} typical values

Frequencies

Frequency ranges

low v.h.f.

channel E2 (picture carrier 48,25 MHz) to
channel S1 (picture carrier 105,25 MHz).

Margin at the extreme channels: min. 1,5 MHz.

high v.h.f.

channel S2 (picture carrier 112,25 MHz) to
channel S19 (picture carrier 287,25 MHz).

Margin at the extreme channels: min. 2 MHz.

u.h.f.

channel E21 (picture carrier 471,25 MHz) to
channel E69 (picture carrier 855,25 MHz).

Margin at the extreme channels: min. 3 MHz.

Intermediate frequencies

picture

38,9 MHz

sound

33,4 MHz

The oscillator frequency is above the aerial
signal frequency.

Wanted signal characteristics

Input impedance

75 Ω

V.S.W.R. and reflection coefficient

(values between picture and sound carrier,
as well as values at picture carrier)

v.s.w.r.

at nominal gain

during gain control

v.h.f.

max. 4

max. 4

u.h.f.

max. 5

max. 6

reflection coefficient

v.h.f.

max. 60%

max. 60%

u.h.f.

max. 66%

max. 71%

R.F. curves, bandwidth

low v.h.f.

typ. 10 MHz

high v.h.f.

typ. 13 MHz

u.h.f.

typ. 18 MHz

R.F. curves, tilt

on any channel the amplitude difference between the top of the r.f. resonant curve and the picture frequency, the sound frequency, or any frequency between them will not exceed 3 dB at nominal gain, and 4 dB in the a.g.c. range between nominal gain and 20 dB gain reduction.*

A.G.C. range

v.h.f.	min. 40 dB
u.h.f.	min. 30 dB

Power gain (see also Measuring method of power gain)

v.h.f., except channels S2, S3, S4	min. 20 dB
channels S2 and S3	min. 17 dB
channel S4	min. 19 dB
channel E3	typ. 28 dB
channel E5	typ. 28 dB
channel E12	typ. 28 dB
u.h.f.	min. 20 dB
channel E21	typ. 28 dB
channel E40	typ. 26 dB
channel E69	typ. 25 dB

Maximum gain difference

between any two v.h.f. channels, except channel S2	typ. 8 dB
between any two v.h.f. channels	typ. 4 dB
between any two u.h.f. channels	typ. 4 dB
between any v.h.f. and u.h.f. channel, except channel S2	typ. 8 dB
between any v.h.f. and u.h.f. channel	typ. 10 dB

Noise figure

v.h.f., except channels S2 and S3	max. 8 dB
channels S2 and S3	max. 10 dB
channel E3	typ. 5 dB
channel E5	typ. 5 dB
channel E12	typ. 6 dB
u.h.f.	max. 10 dB
channel E21	typ. 6 dB
channel E40	typ. 6 dB
channel E69	typ. 8 dB

Overloading

Input signal producing 1 dB gain compression at nominal gain

v.h.f.	typ. 87 dB (μ V) into 75 Ω
u.h.f.	typ. 90 dB (μ V) into 75 Ω

Input signal producing either a detuning of the oscillator of + 300 kHz or -1000 kHz or stopping of the oscillations at nominal gain

v.h.f.	typ. 100 dB (μ V) into 75 Ω
u.h.f.	typ. 100 dB (μ V) into 75 Ω

* 1 dB higher values on channels S17, S18, S19.

Unwanted signal characteristics

Image rejection (measured at picture carrier frequency)

v.h.f.

min. 60 dB; typ. 65 dB

u.h.f.

min. 46 dB; typ. 52 dB

I.F. rejection (measured at picture carrier frequency)

channel E2

min. 55 dB

channels E3 to S1

min. 60 dB

high v.h.f.

min. 60 dB

u.h.f.

min. 60 dB

Note: At colour sub-carrier frequency maximum 6 dB less rejection.

N ± 4 rejection (for u.h.f. only)

Interference signal for an interference ratio of 53 dB

referred to wanted picture carrier (picture to sound

carrier ratio of 10 dB; wanted signal 60 dB (μV);

tuner operating at nominal gain)

N + 4 interference signal

typ. 80 dB (μV) into 75 Ω

N - 4 interference signal

typ. 74 dB (μV) into 75 Ω

Cross modulation

Input signal producing 1% cross modulation, i.e. 1% of the modulation depth of the interference signal is transferred to the wanted signal.

In channel cross modulation (wanted signal: picture carrier frequency; interference signal: sound carrier frequency)

v.h.f.

at nominal gain (wanted input level 60 dB (μV))

typ. 74 dB (μV) into 75 Ω

at 40 dB gain reduction (wanted input level 100 dB (μV))

typ. 94 dB (μV) into 75 Ω

u.h.f.

at nominal gain (wanted input level 60 dB (μV))

typ. 74 dB (μV) into 75 Ω

at 30 dB gain reduction (wanted input level 90 dB (μV))

typ. 94 dB (μV) into 75 Ω

In band cross modulation (wanted signal: picture carrier of channel N; interference signal: picture carrier of channel N ± 2 for low v.h.f., or channel N ± 3 for high v.h.f., or channel N ± 5 for u.h.f.)

v.h.f.

at nominal gain (wanted input level 60 dB (μV))

typ. 85 dB (μV) into 75 Ω

at 40 dB gain reduction (wanted input level 100 dB (μV))

typ. 97 dB (μV) into 75 Ω

u.h.f.

at nominal gain (wanted input level 60 dB (μV))

typ. 82 dB (μV) into 75 Ω

at 30 dB gain reduction (wanted input level 90 dB (μV))

typ. 94 dB (μV) into 75 Ω

Out of band cross modulation at nominal gain

low v.h.f., interference from high v.h.f.

typ. 94 dB (μV) into 75 Ω

low v.h.f., interference from u.h.f.

typ. 90 dB (μV) into 75 Ω

high v.h.f., interference from low v.h.f.

typ. 94 dB (μV) into 75 Ω

high v.h.f., interference from u.h.f.

typ. 90 dB (μV) into 75 Ω

u.h.f. interference from low v.h.f.

typ. 94 dB (μV) into 75 Ω

u.h.f. interference from high v.h.f.

typ. 86 dB (μV) into 75 Ω

Oscillator characteristics

Pulling

Input signal of tuned frequency producing a shift of the oscillator frequency of 10 kHz, at nominal gain

v.h.f.
u.h.f.

typ. 78 dB (μ V) into 75 Ω
typ. 80 dB (μ V) into 75 Ω

Shift of oscillator frequency at a change of the supply voltage of 5%

v.h.f.
u.h.f.

max. 250 kHz
max. 500 kHz

Drift of oscillator frequency

during warm-up time (after the tuner has been completely out of operation for 15 min, measured between 5 s and 15 min after switching on)

max. 250 kHz

during warm-up time (after the input stage is in operation for 15 min, measured between 2 s and 15 min after band switching)

max. 250 kHz

at a change of the ambient temperature from + 25 to + 40 °C (measured after 3 cycles from + 25 to + 55 °C)

low v.h.f.
high v.h.f.
u.h.f.

max. 300 kHz
max. 450 kHz
max. 500 kHz

Frequency divider characteristics; only valid for UV416

Supply voltage

+ 5 V \pm 5%

Current drawn from + 5 V supply

v.h.f.
u.h.f.

max. 45 mA; typ. 35 mA
max. 55 mA; typ. 45 mA

Output voltage

3,4 to 10 V, depending on load and supply voltage

Output current

at output voltage 3,4 V
at output voltage 5 V

min. 1 mA
max. 1,5 mA

Interference signal on the i.f. output

max. 3 μ V

Note: I.F. output of the tuner terminated with the circuit shown in Fig. 10.

I.F. circuit characteristics

Bandwidth of i.f. output circuit

5,5 \pm 1 MHz

Note: I.F. output of the tuner terminated with the circuit shown in Fig. 10; tuning voltage 17 V; u.h.f. band switched on.

Bandwidth variation of i.f. output circuit as a result of r.f. tuning and band switching (reference: u.h.f.; tuning voltage 17 V)

max. 500 kHz

Note: I.F. output of the tuner terminated with a modified circuit of Fig. 10, i.e. a 100 pF capacitor is connected in parallel with the i.f. output of the tuner.



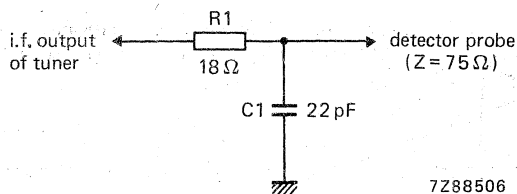

Fig. 10.

Detuning of the i.f. output circuit as a result of r.f. tuning and band switching (reference: u.h.f.; tuning voltage 17 V)

max. 500 kHz

Note: I.F. output of the tuner terminated with a modified circuit of Fig. 10, i.e. a 100 pF capacitor is connected in parallel with the i.f. output of the tuner.

Minimum tuning range of i.f. output coil

33 to 40 MHz

Note: I.F. output of the tuner terminated with the circuit shown in Fig. 10.

Attenuation between i.f. injection point and i.f. output of the tuner

typ. 16 dB

Miscellaneous

Radio interference

Oscillator radiation and oscillator voltage at the aerial terminal

Within the limits of C.I.S.P.R. 13 (1975) and VDE0872/7.72.

Microphonics

There will be no microphonics, provided the tuner is installed in a professional manner.

Surge protection

Protection against voltages

max. 5 kV

Note: 10 discharges of a 470 pF capacitor into the aerial terminal.

Protection against flashes

max. 30 kV, 400 mWs

Note: A flashover circuit producing flashes with frequencies of 1 to 20 Hz for 30 s is connected to the aerial terminal.

ADDITIONAL INFORMATION

I.F. injection

Terminal 4 (supply voltage u.h.f.) can be used as i.f. injection point, provided the u.h.f. supply voltage is applied to terminal 4 via a resistor of $10\ \Omega$ (see Fig. 11). The u.h.f. band should be switched on; tuning voltage should be $17\ \text{V}$.

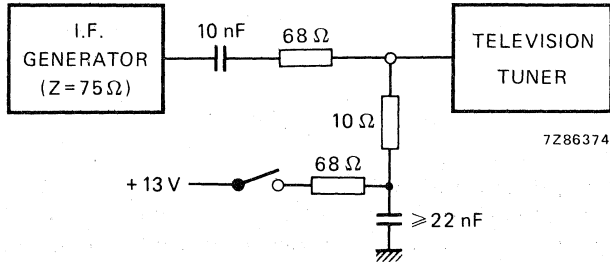
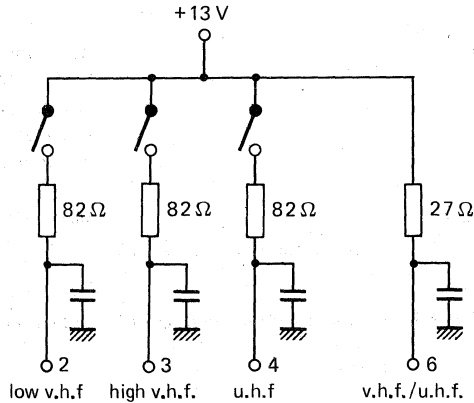

Fig. 11.

Connection of the i.f. amplifier

No special precautions are required to load and to match the i.f. output of the tuner.

Connection of supply voltages



7288507

Fig. 12.

Measuring method of power gain

The i.f. output of the tuner should be terminated with the RC-circuit given in Fig. 10.

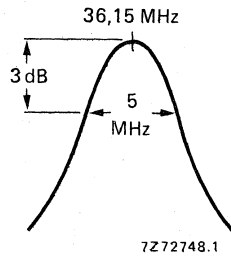

Fig. 13.

The RC-circuit roughly matches the i.f. output impedance to 75Ω at the resonant frequency of the i.f. output circuit, which should be tuned to 36,15 MHz; the bandwidth is approx. 5 MHz (Fig. 13).

Because the input and output impedances of the tuner are now 75Ω , the power gain can be measured in the conventional manner by inserting tuner and RC-circuit between a 75Ω source and a 75Ω detector.

Alignment of the i.f. output coil

The i.f. output coil should be adjusted with a brass tool with a blade as shown in Fig. 14. A suitable tool is available under catalogue number 7122 005 47680.

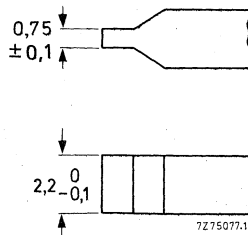

Fig. 14.

DEVELOPMENT SAMPLE DATA

This information is derived from development samples made available for evaluation. It does not necessarily imply that the device will go into regular production.

UVF10

V.H.F./U.H.F. TELEVISION TUNER

QUICK REFERENCE DATA

Systems	C.C.I.R. systems L and L'
Channels	
v.h.f. I	A to E4, including A to C
v.h.f. III	M4 to E12, including 1 to 6
u.h.f.	E21 to E69
Intermediate frequencies	
picture	32,7 MHz
sound	39,2 MHz

APPLICATION

Designed to cover the v.h.f. and u.h.f. channels of C.C.I.R. systems L and L'.

REVISION
REVISION
REVISION
REVISION
REVISION

DESCRIPTION

The UVF10 is a combined v.h.f./u.h.f. tuner with electronic tuning and band switching covering the v.h.f. band I including the European channel E4 (frequency range 41 to 68 MHz), the v.h.f. band III including the Moroccan channel M4 and the European channel E12 (frequency range 162 to 230 MHz) and the u.h.f. band (frequency range 470 to 861 MHz).

Mechanically, the tuner is built on a low-loss printed-wiring board, carrying all components, in a metal housing made of a rectangular frame and front and rear covers (see Fig. 2). The common aerial connection (v.h.f. and u.h.f.) with standard coaxial termination is on one of the frame sides, all other connections (supply voltages, a.g.c. voltage, tuning and switching voltages, i.f. output) are made via terminals in the underside. The mounting method is shown in Fig. 3.

Electrically, the tuner consists of v.h.f. and u.h.f. parts. The v.h.f. aerial signal is fed via switchable v.h.f. band I/III wideband input filters to gate 1 of an input MOSFET tetrode (with internal gate protection against surge).

The drain load of the MOSFET tetrode is formed by a double tuned switchable bandpass filter, transferring the r.f. signal to the emitter of the mixer transistor. The oscillator signal is also fed to the emitter of the mixer transistor.

The collector circuit of the mixer transistor is a single tuned i.f. resonant circuit, at the low end of which the i.f. signal is coupled out of the tuner. A test point (terminal 4) is provided for i.f. injection to align the output circuit of the tuner together with the i.f. amplifier of the television receiver.

The input tuned circuit, the r.f. bandpass filter and oscillator circuit are tuned by 4 tuning diodes, band switching is achieved by 8 switching diodes.

The u.h.f. part of the tuner consists of a tuned input circuit connected to gate 1 of an input MOSFET tetrode (with internal gate protection against surge). The drain load of this MOSFET tetrode is formed by a double tuned circuit transferring the r.f. signal to the Schottky barrier mixer diode. The i.f. signal from the mixer diode is amplified by the v.h.f. mixer transistor, now operating as an i.f. amplifier.

The input tuned circuit, the r.f. bandpass filter and oscillator circuits are tuned by 4 tuning diodes.

In all bands the tuner is gain controlled via gate 2 of the input MOSFET tetrodes.

DEVELOPMENT SAMPLE DATA

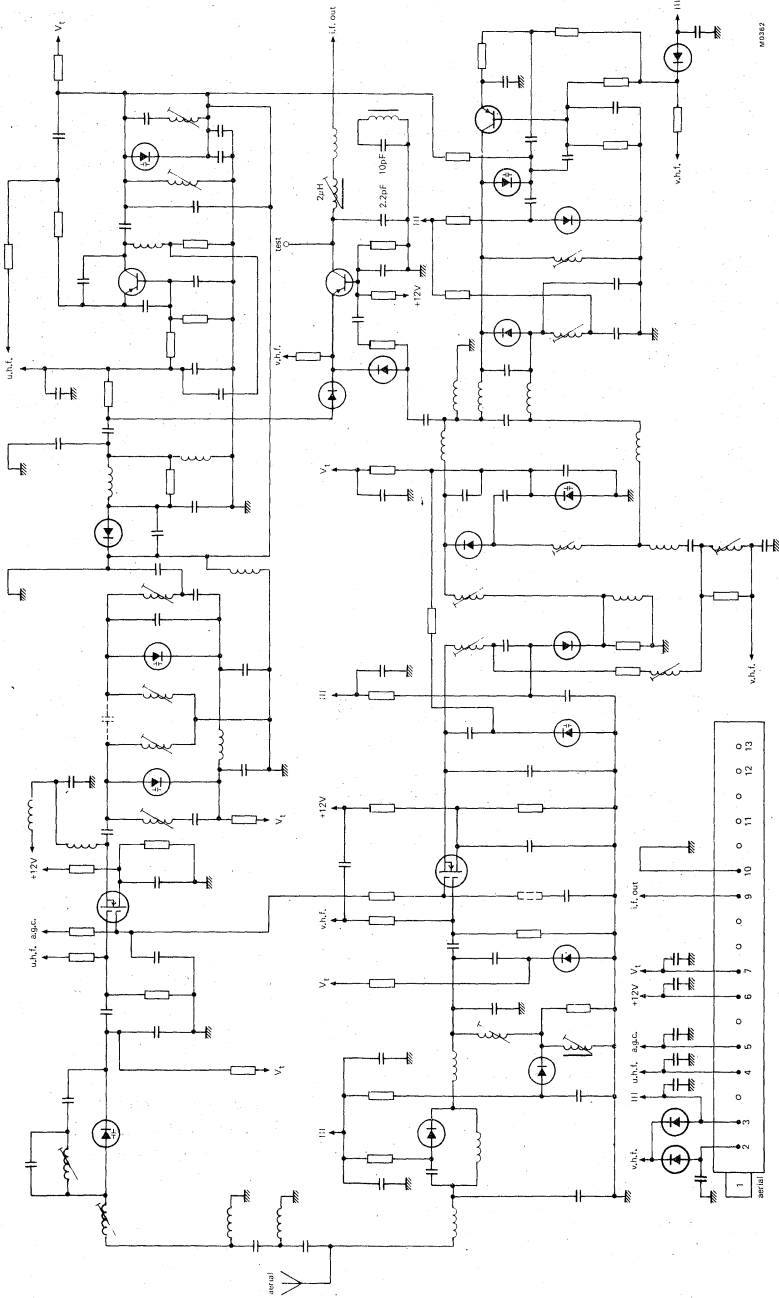
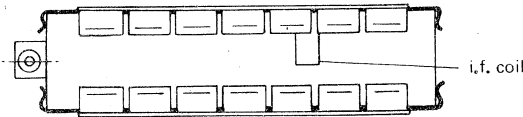
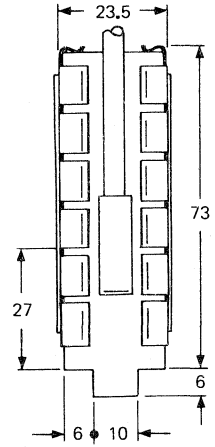
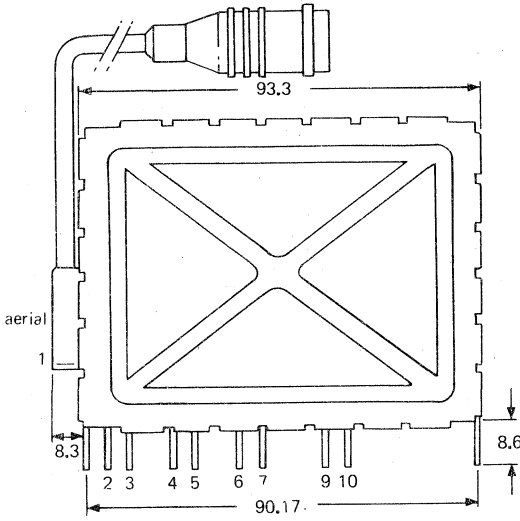

Fig. 1.



MECHANICAL DATA

Dimensions in mm



M0363

Fig. 2a.

- Terminal
- 1 = aerial
 - 2 = supply voltage, v.h.f. I, +12 V
 - 3 = supply voltage, v.h.f. III, +12 V
 - 4 = supply voltage, u.h.f., +12 V; i.f. injection
 - 5 = a.g.c. voltage, +8,25 to +0,85 V
 - 6 = supply voltage, v.h.f. and u.h.f., +12 V
 - 7 = tuning voltage, +0,5 to +28 V
 - 9 = i.f. output
 - 10 = earth

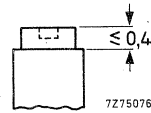

Fig. 2b I.F. output coil.
Torque for alignment: 2 to 15 mNm
Press-through force: ≥ 10 N.

Mass approx. 130 g

Mounting

The tuner may be mounted by soldering it onto a printed-wiring board, using the piercing diagram shown in Fig. 3. (The tuner may also be mounted by means of a socket. Information will be supplied upon request.) The tuner may be mounted anywhere in the receiver and there are no restrictions on orientation.

Dimensions in mm

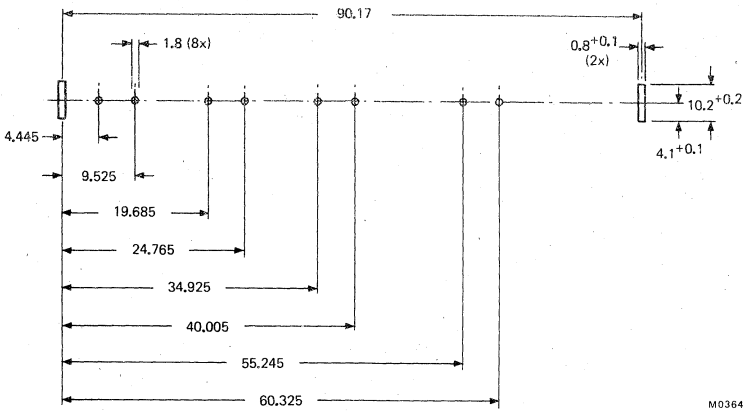

M0364

Fig. 3 Piercing diagram viewed from solder side of board. Unless otherwise stated the tolerance is $\pm 0,05$ mm.

DEVELOPMENT SAMPLE DATA

ELECTRICAL DATA

Unless otherwise specified all electrical values apply at an ambient temperature of $25 \pm 5 \text{ }^\circ\text{C}$, a relative humidity of $60 \pm 15\%$, a supply voltage of $12 \pm 0,3 \text{ V}$ and an a.g.c. voltage of $8,25 \pm 0,2 \text{ V}$.

Voltages and currents

Supply voltage	+ 12 V \pm 1 V
Current drawn from + 12 V supply	
band I	max. 45 mA; typ. 40 mA
band III	max. 60 mA; typ. 55 mA
bands IV and V	max. 50 mA; typ. 45 mA

Bandswitching

For operation in all bands the supply voltage is permanently connected to terminal 6. Additionally the supply voltage is connected to:

- terminal 2 and -12 V to terminal 3 for operation in band I
- terminal 3 and -12 V to terminal 2 for operation in band II
- terminal 4 and -12 V to terminals 2 and 3 for operation in bands IV and V.

A.G.C. voltage (Figs 4, 5 and 6)	
voltage range	+ 8,25 to + 0,85 V
voltage at nominal gain	+ 8,25 \pm 0,5 V
voltage at 40 dB gain reduction	
band I	typ. 2 V
band III	typ. 1,2 V

Note: A.G.C. voltages between 0 and + 10,5 V may be applied without risk or damage.

A.G.C. current	max. 0,3 μA
Tuning voltage range (Figs 7, 8 and 9)	+ 0,5 to + 28 V
Current drawn from 28 V tuning voltage supply	
at $T_{\text{amb}} = 25 \text{ }^\circ\text{C}$	max. 0,5 μA
at $T_{\text{amb}} = 55 \text{ }^\circ\text{C}$	max. 2 μA

Slope of tuning characteristics (typical values)	
band I, channel A	2 MHz/V
band I, channel C	0,8 MHz/V
band III, channel 1	4,5 MHz/V
band III, channel 6	2,5 MHz/V
bands IV and V, channel 21	30 MHz/V
bands IV and V, channel 69	6 MHz/V

Frequencies

Frequency ranges	
band I	channel A (picture carrier 47,75 MHz) Margin: min. tuning voltage 0,5 V
	channel E4 (picture carrier 62,25 MHz) Margin: min. 800 kHz

DEVELOPMENT SAMPLE DATA

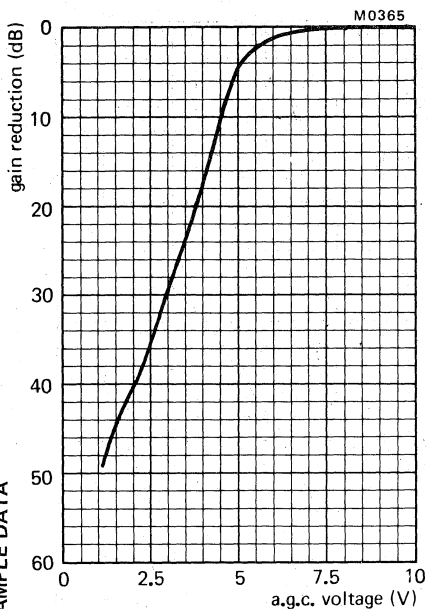

Fig. 4 Typical a.g.c. characteristic, band I.

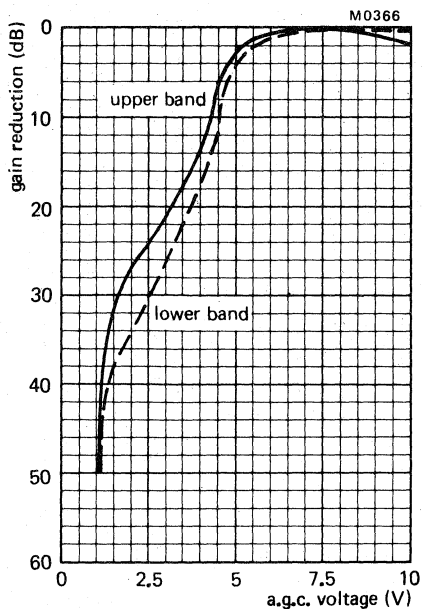

Fig. 5 Typical a.g.c. characteristic, band III.

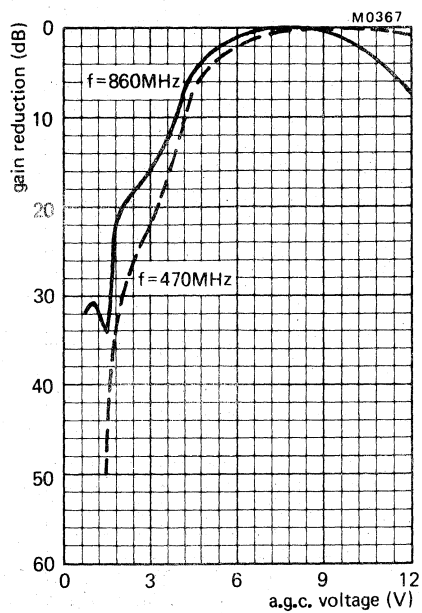

Fig. 6 Typical a.g.c. characteristic, bands IV and V.



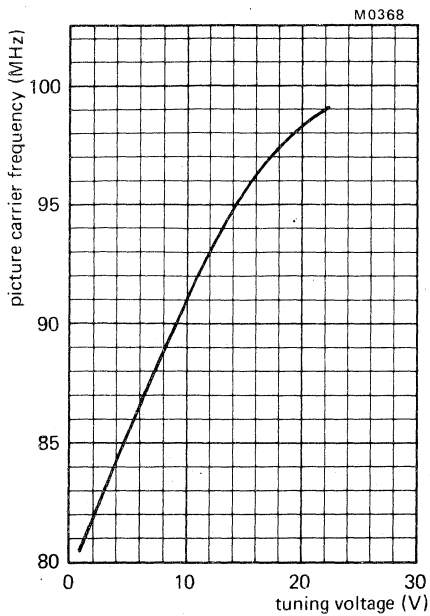

Fig. 7 Typical tuning characteristic, band I.

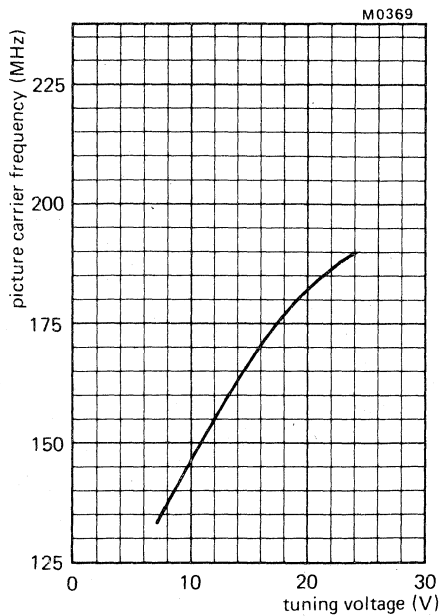

Fig. 8 Typical tuning characteristic, band III.

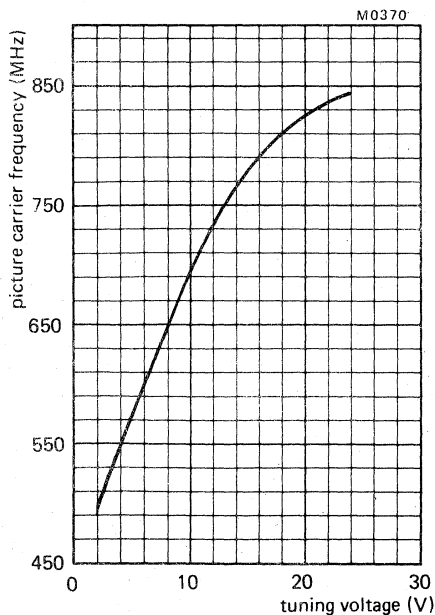

Fig. 9 Typical tuning characteristic, bands IV and V.

Frequencies (continued)

Frequency range
band III

channel M4 (picture carrier 163,25 MHz)
Margin: min. 2 MHz

channel E12 (picture carrier 224,25 MHz)
Margin: min. 1,8 MHz

bands IV and V

channel E21 (picture carrier 471,25 MHz) to
channel E69 (picture carrier 855,25 MHz)
Margin at the extreme channels: 2 MHz

Intermediate frequencies
picture
sound

32,7 MHz

39,2 MHz

Wanted signal characteristics

Input impedance

75 Ω

V.S.W.R. and reflection coefficient
(values between picture and sound carrier,
as well as values at picture carrier)

at nominal gain during gain control

v.s.w.r.

bands I and III

max. 4

max. 4

bands IV and V

max. 5

max. 6

reflection coefficient

bands I and III

max. 63%

max. 63%

bands IV and V

max. 56%

max. 56%

R.F. curves, bandwidth

band I

typ. 16 MHz

band III

typ. 16 MHz

bands IV and V

typ. 30 MHz

R.F. curves, tilt

on any channel the amplitude difference between
the top of the r.f. resonant curve and the picture
frequency, the sound frequency, or any frequency
between them will not exceed:

nominal gain

in the first 20 dB
of the a.g.c. range

band I

3 dB

4 dB

band III

3 dB

4,5 dB

bands IV and V

3 dB

4 dB

A.G.C. range

bands I and III

min. 40 dB

bands IV and V

min. 30 dB

DEVELOPMENT SAMPLE DATA



Wanted signal characteristics (continued)

Power gain (see also measuring method for power gain Figs 11 and 12)	
bands I and III	min. 22 dB
bands IV and V	min. 19 dB
Maximum gain difference	
between any two v.h.f. channels	typ. 4 dB
between any two u.h.f. channels	typ. 6 dB
Noise figure	
bands I and III	max. 7,5 dB
band I	typ. 6 dB
band III	typ. 5 dB
bands IV and V	max. 10 dB
channel E21	typ. 5,5 dB
channel E40	typ. 6,5 dB
channel E69	typ. 7,5 dB

Unwanted signal characteristics

Image rejection (measured at picture carrier frequency)	
band I	min. 60 dB
band III	min. 40 dB
bands IV and V	min. 40 dB
I.F. rejection (measured at picture carrier frequency)	
band I	
channel A	min. 12 dB
channel B	min. 20 dB
channel C	min. 30 dB
band III	min. 60 dB
bands IV and V	min. 60 dB

Cross modulation

Input signal producing 1% cross modulation, i.e. 1% of the modulation depth of the interfering signal is transferred to the wanted signal.

In channel cross modulation (wanted signal: picture carrier frequency; interfering signal: sound carrier frequency)

band I	
at nominal gain (wanted input level 60 dB (μV))	typ. 67 dB (μV) into 75 Ω
at 20 dB gain reduction	typ. 85 dB (μV) into 75 Ω
band III	
at nominal gain	typ. 70 dB (μV) into 75 Ω
at 20 dB gain reduction	typ. 90 dB (μV) into 75 Ω
bands IV and V	
at nominal gain	typ. 70 dB (μV) into 75 Ω
at 20 dB gain reduction	typ. 90 dB (μV) into 75 Ω

In band cross modulation (wanted signal: picture carrier of channel N; interfering signal: picture carrier of channel $N \pm 3$ for bands I, III, IV and V).

band III

at nominal gain (wanted input level 60 dB (μ V))

typ. 95 dB (μ V) into 75 Ω

bands IV and V

at nominal gain

typ. 85 dB (μ V) into 75 Ω

Oscillator characteristics

Shift of oscillator frequency at a change of the supply voltage 5%

bands I and III

max. 200 kHz

bands IV and V

max. 1000 kHz

channel 21

typ. 600 kHz

channel 40

typ. 100 kHz

channel 69

typ. 200 kHz

Drift of oscillator frequency at a change of the ambient temperature from +25 to +40 $^{\circ}$ C (measured after 3 cycles from +25 to +55 $^{\circ}$ C)

bands I and III

max. 350 kHz

bands IV and V

max. 600 kHz

I.F. circuit characteristics

Minimum tuning range of i.f. output coil

32 to 40 MHz

Miscellaneous

Oscillator voltage at the aerial terminal

Fundamental and harmonic frequencies up to 1000 MHz

bands I and III

max. 50 dB (μ V) into 75 Ω

bands IV and V

max. 66 dB (μ V) into 75 Ω



ADDITIONAL INFORMATION

I.F. injection

Terminal 4 (supply voltage u.h.f.) can be used as i.f. injection point, provided the u.h.f. supply voltage is applied to terminal 4 via a resistor of $56\ \Omega$ (see Fig. 10). The u.h.f. band should be switched on; a tuning voltage of $-12\ \text{V}$ is applied to terminal 7.

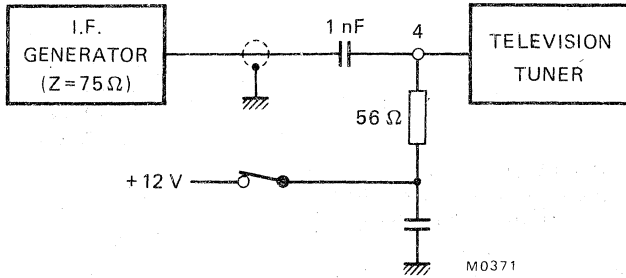

Fig. 10.

Connection of the i.f. amplifier

No special precautions are required to load and to match the i.f. output of the tuner.

Measuring method of power gain

The i.f. output of the tuner should be terminated with the circuit given in Fig. 11.

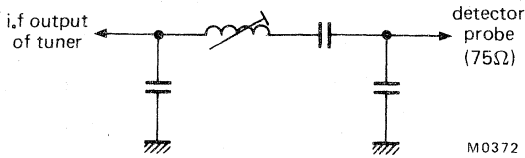

Fig. 11.

This circuit roughly matches the i.f. output impedance to $75\ \Omega$ at the resonant frequency of the i.f. output circuit (Fig. 12).

Because the input and output impedances of the tuner are now $75\ \Omega$, the power gain can be measured in the conventional manner by inserting tuner and the circuit between a $75\ \Omega$ source and a $75\ \Omega$ detector.

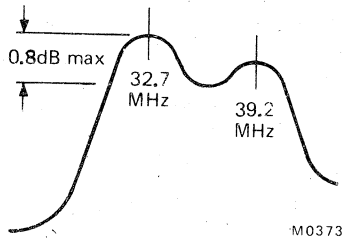

Fig. 12.

Alignment of the i.f. output coil

The i.f. output coil should be adjusted with a brass tool with a blade as shown in Fig. 13. A suitable tool is available under catalogue number 7122 005 47680.

DEVELOPMENT SAMPLE DATA

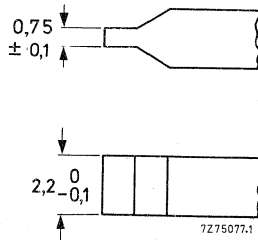

Fig. 13.

V.H.F. TELEVISION TUNER

- with diode tuning

QUICK REFERENCE DATA

Systems	C.C.I.R. systems B and I	
	system B	system I
Channels		
v.h.f. I	NZ1 to E4	IA to IC
v.h.f. III	E5 to E12	ID to IJ
Intermediate frequencies		
picture	38,9 MHz	39,5 MHz
sound	33,4 MHz	33,5 MHz

APPLICATION

This tuner is designed to cover the v.h.f. channels of C.C.I.R. systems B and I. In combination with the u.h.f. tuner U322 it can be used in v.h.f./u.h.f. receivers. The aerial inputs and i.f. outputs of both tuners can then be connected in parallel without additional circuitry.

DESCRIPTION

The V311 is a v.h.f. tuner with electronic tuning, covering the v.h.f. band I (44 to 68 MHz) and the v.h.f. band III (174 to 230 MHz). Switching between the bands is done automatically by a built-in comparator circuit.

Mechanically, the tuner is built on a printed-wiring board, carrying all components, in a metal housing made of a rectangular frame and front and rear cover (see Fig. 2). All connections (aerial, supply voltage, a.g.c. voltage, tuning voltage, i.f. injection, i.f. output) are made via terminals on the under side. The mounting method is shown in Fig. 3.

Electrically the tuner consists of two input circuits in parallel (bands I and III) with band-pass characteristics, followed by a p-i-n diode attenuator (2 diodes BA379) and the input transistor AF379 in grounded-base configuration. This transistor operates at an emitter current of about 4 to 12 mA, featuring good noise figures and good signal handling properties. It also supplies the current drive for the p-i-n diode attenuator, controlled by an a.g.c. voltage fed to the transistor's base. This combination has good signal handling properties throughout the a.g.c. range.

The collector load of the input transistor is formed by a double tuned circuit, transferring the signal to the self-oscillating mixer AF367. The selectivity of this circuit at the intermediate frequency has been improved.

Four capacitance diodes BB106 tune the double-tuned circuit and the oscillator.

The i.f. output circuit of the tuner is a single tuned one, at the low end of which the i.f. signal is coupled out of the tuner. A d.c. path to earth for the collector current of the mixer has to be provided outside the tuner, preferably by a choke of about 5 μ H. Damping of the i.f. output circuit and matching of the i.f. output to the i.f. circuit of the receiver can be achieved by connecting a series resistance and a parallel capacitance outside the tuner.

An i.f. injection point has been provided at the collector of the mixer transistor, connected to terminal S.

A comparator circuit supplying the automatic switching-over between bands I and III consists of two p-n-p transistors, the emitters of which have the same stabilized 5,6 V reference voltage, thereby supplying a very good temperature and supply voltage dependence. The voltage divider at the input of the circuit consists of two high-ohmic resistors to prevent unacceptable loading of the tuning voltage.

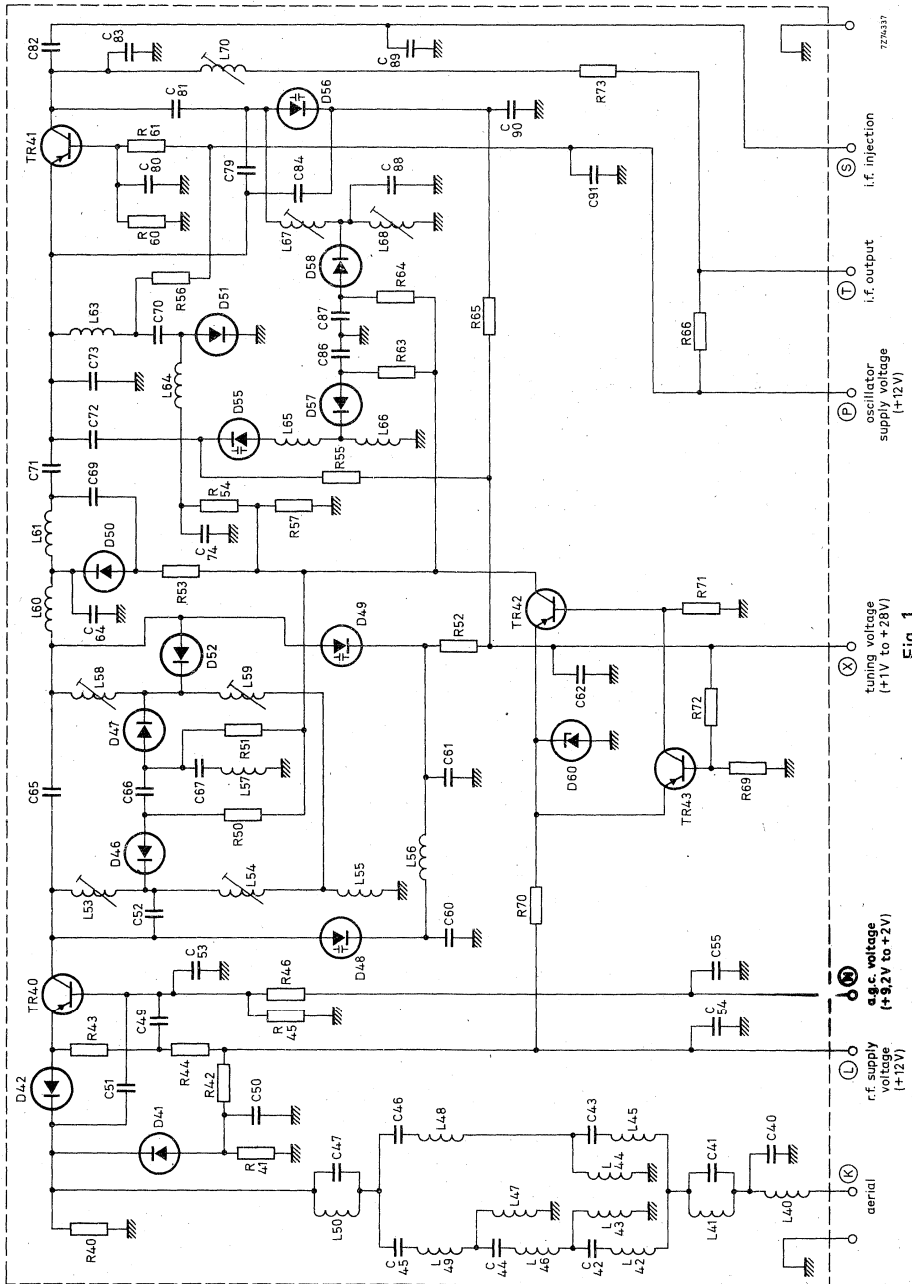

Fig. 1.

MECHANICAL DATA

Dimensions in mm

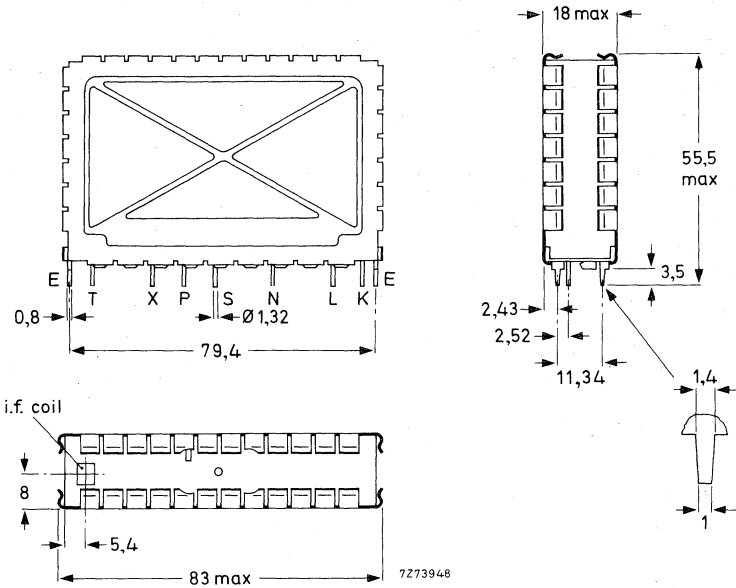

Fig. 2a.

- Terminal T = i.f. output
- X = tuning voltage, + 1 to + 28 V
- P = self-oscillating mixer supply voltage, + 12 V
- S = i.f. injection point
- N = a.g.c. voltage, + 9,2 to + 2 V
- L = r.f. supply voltage, + 12 V
- K = aerial

Note

When the tuner is operated together with a u.h.f. tuner, only the supply voltage at terminal P should be switched off during u.h.f. operation.

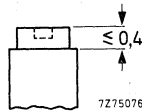

Fig. 2b I.F. output coil.
Torque for alignment: 2 to 15 mNm
Press-through force: ≥ 10 N

Mass

approx. 80 g

Mounting

The tuner may be mounted by soldering it on to a printed-wiring board, using the piercing diagram shown in Fig. 3. (The tuner may also be mounted by means of a socket. Information will be supplied upon request).

It is recommended that the tuner be installed in the cool part of the receiver cabinet and not exposed to the vibrations of the loudspeaker. There are no restrictions on orientation.

The solderability of the terminals and mounting tabs is according to IEC 68-2, test Ta ($230 \pm 10 \text{ }^\circ\text{C}$, $2 \pm 0,5 \text{ s}$). The resistance to soldering heat is according to IEC 68-2, test Tb ($260 \pm 5 \text{ }^\circ\text{C}$, $10 \pm 1 \text{ s}$).

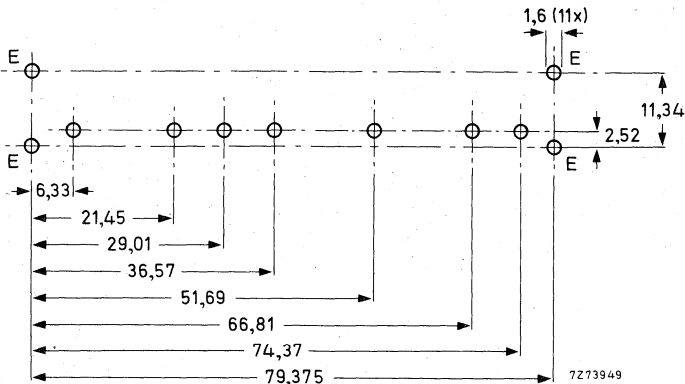

Fig. 3 Piercing diagram viewed from solder side of board.

ELECTRICAL DATA

The electrical values are measured on the v.h.f. tuner alone, but they are also valid for the v.h.f. tuner in combination with a u.h.f. tuner U322.

Unless otherwise specified all electrical values apply at an ambient temperature of 25 ± 5 °C, a relative humidity of $60 \pm 15\%$, a supply voltage of $12 \pm 0,3$ V and an a.g.c. voltage of $9,2 \pm 0,2$ V.

Within the given tolerance range of supply voltage and a.g.c. voltage only insignificant deviations from the specified values can be expected.

Under the extreme conditions of temperature and humidity as given below, the tuner will function normally, but some specified limits may be exceeded.

General**Semiconductors**

p-i-n diodes	2 x BA379
r.f. amplifier	AF379
self-oscillating mixer	AF367
tuning diodes	4 x BB106
switching diodes	BA220; 6 x BA243
bandswitch comparator	BZX79; 2 x BC558

Ambient temperature range

operating	+ 5 to + 55 °C
storage	-25 to + 85 °C

Relative humidity

max. 90%

Voltages and currents

Supply voltage	+ 12 V \pm 10%
----------------	------------------

Note

The supply voltage at terminal L (input stage) should be filtered to avoid hum modulation in one of the p-i-n diodes when the attenuator is biased to higher attenuation ratios.

Current drawn from + 12 V supply

r.f. amplifier + bandswitch circuit	
v.h.f. I, at nominal gain	typ. 40 mA
at 40 dB gain reduction	typ. 42 mA
v.h.f. III, at nominal gain	typ. 40 mA
at 40 dB gain reduction	typ. 42 mA
self-oscillating mixer	typ. 4,5 mA

Bandswitching

Switching between v.h.f. I and v.h.f. III is done automatically within the tuner. If the tuner operates together with a u.h.f. tuner only the supply voltage at terminal P should be switched off during u.h.f. operation.

A.G.C. voltage (Figs 4, 5 and 6)
 at nominal gain
 at 40 dB gain reduction

+ 9,2 ± 0,5 V
 min. + 2 V

Note

A.G.C. voltages between 0 and + 10 V may be applied without risk of damage.

A.G.C. current (Fig. 7), during gain control
 (0 to 40 dB)
 at nominal gain
 at 40 dB gain reduction

max. + 1 mA
 typ. + 0,8 mA
 typ. + 0,2 mA

Tuning voltage range (Fig. 8)

+ 1 to + 28 V
 -4 to + 11 μA

Current drawn from + 28 V tuning voltage supply (Fig. 9)

Note

The source impedance of the tuning voltage offered to terminal X must be max. 47 kΩ.

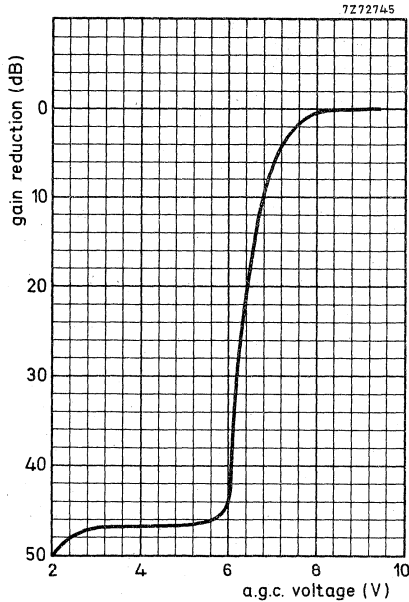

Fig. 4 A.G.C. voltage characteristic, channel E2; typical curve.

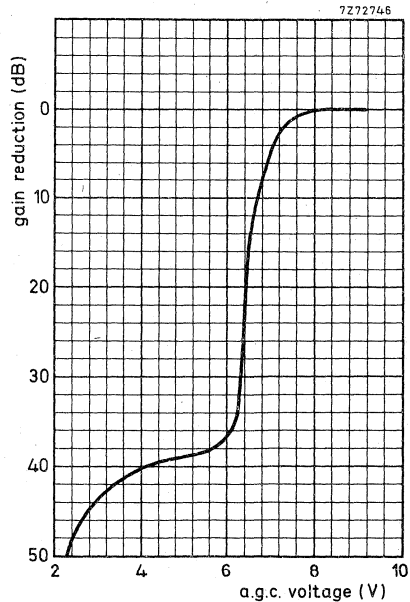

Fig. 5 A.G.C. voltage characteristic, channel E5; typical curve.

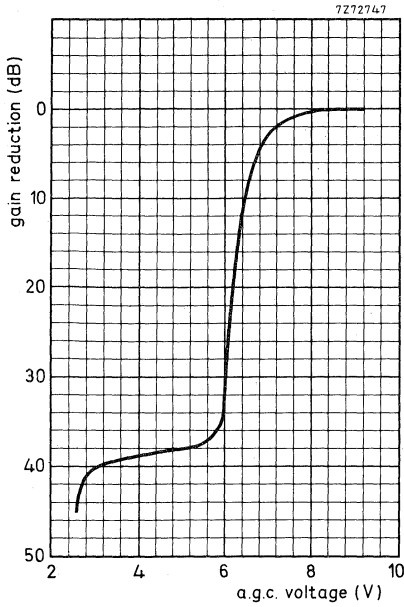

Fig. 6 A.G.C. voltage characteristic, channel E12; typical curve.

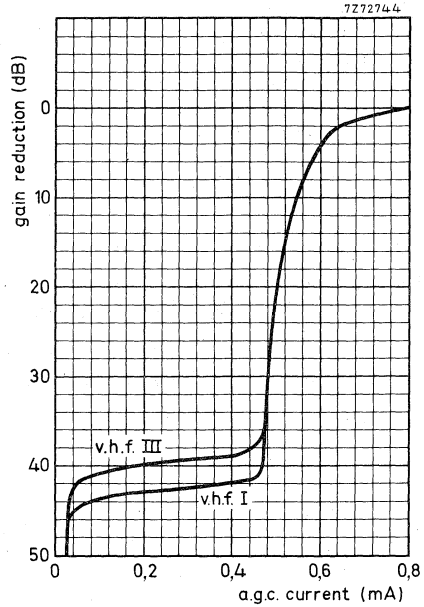

Fig. 7 A.G.C. current characteristic; typical curves.

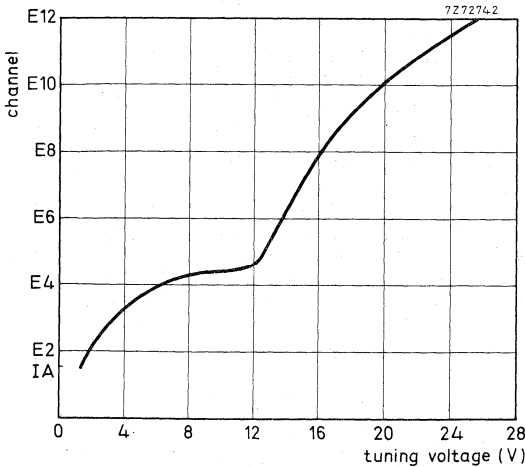

Fig. 8 Tuning voltage characteristic; typical curve.

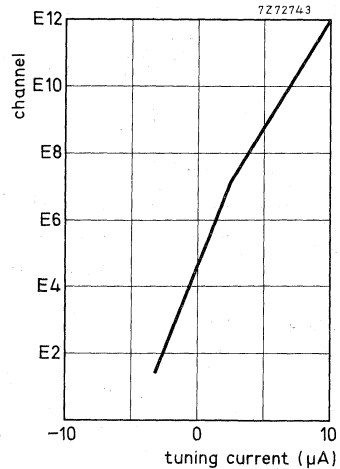

Fig. 9 Tuning current characteristic; typical curve.

Frequencies

Frequency ranges

v.h.f. I

channel NZ1 (picture carrier 45,25 MHz)
to channel E4 (picture carrier 62,25 MHz).
Margin at the extreme channels: min. 1 MHz.

v.h.f. III

channel E5 (picture carrier 175,25 MHz)
to channel E12 (picture carrier 224,25 MHz).
Margin at the extreme channels: min. 1,5 MHz.

Intermediate frequencies

picture

system Bsystem I

sound

38,9 MHz

39,5 MHz

33,4 MHz

33,5 MHz

The oscillator frequency is higher than the aerial
signal frequency.

Note

The tuner is aligned in such a way that the i.f. frequencies of both systems can be applied.

Wanted signal characteristics

Input impedance, asymmetrical

75 Ω

minimum value
between picture
carrier and sound
carrier frequency

maximum value
at picture carrier
frequency

V.S.W.R.

max. 4

max. 4

Reflection coefficient

max. 60%

max. 60%

A.G.C. range

min. 40 dB

R.F. curves

bandwidth

typ. 10 MHz

tilt (only for i.f. 38,9/33,4 MHz)

on any channel the amplitude difference between
the top of the r.f. resonant curve and the picture
carrier marker, the sound carrier marker, or any
frequency between them will not exceed 3 dB
at nominal gain, and 4 dB in the a.g.c. range
between nominal gain and 20 dB gain reduction.

Power gain (see also 'Measuring method
of power gain')

channel E3

min. 20 dB

channel E5

typ. 25 dB

channel E12

typ. 25 dB

typ. 26 dB

Gain difference between any two channels

typ. 4 dB

Noise figure

channel E3

max. 9 dB

channel E5

typ. 5 dB

channel E12

typ. 6,5 dB

typ. 7 dB

Overloading

Input signal producing 1 dB gain compression at nominal gain typ. 88 dB (μ V) into 75 Ω

Input signal producing either a detuning of the oscillator of +300 kHz or -1000 kHz or stopping of the oscillations at nominal gain typ. 90 dB (μ V) into 75 Ω

Unwanted signal characteristics

Image rejection (measured at picture carrier frequency) min. 53 dB

I.F. rejection (measured at picture carrier frequency) channel IA to E12 min. 60 dB

Note

At colour sub-carrier frequency max. 6 dB less rejection.

Cross-modulation

Input signal producing 1% cross-modulation, i.e. 1% of the modulation depth of the interfering signal is transferred to the wanted signal.

In channel cross-modulation (wanted signal: picture carrier frequency; interfering signal: sound carrier frequency)

at nominal gain (wanted input level 60 dB (μ V)) typ. 70 dB (μ V) into 75 Ω

at 40 dB gain reduction (wanted input level 100 dB (μ V)) typ. 106 dB (μ V) into 75 Ω

In band cross-modulation (wanted signal: picture carrier of channel N; interfering signal: picture carrier of channel $N \pm 2$ for v.h.f. I or channel $N \pm 3$ for v.h.f. III)

at nominal gain (wanted input level 60 dB (μ V)) typ. 94 dB (μ V) into 75 Ω

at 40 dB gain reduction (wanted input level 100 dB (μ V)) typ. 100 dB (μ V) into 75 Ω

Out of band cross-modulation at nominal gain

v.h.f. I, interfering from v.h.f. III typ. 92 dB (μ V) into 75 Ω
interfering from u.h.f. typ. 100 dB (μ V) into 75 Ω

v.h.f. III, interfering from v.h.f. I typ. 100 dB (μ V) into 75 Ω
interfering from u.h.f. typ. 100 dB (μ V) into 75 Ω

Oscillator characteristics**Pulling**

Input signal of tuned frequency producing a shift of the oscillator frequency of 10 kHz, at nominal gain
v.h.f. I
v.h.f. III

typ. 73 dB (μV) into 75 Ω
typ. 73 dB (μV) into 75 Ω

Shift of oscillator frequency at a change of the supply voltage of 5%

max. 250 kHz

Drift of oscillator frequency during warm-up time (after the tuner has been completely out of operation for 15 min, measured between 5 s and 15 min after switching on)

max. 250 kHz

during warm-up time (after the input stage is in operation for 15 min, measured between 2 s and 15 min after switching on the self-oscillating mixer stage)

max. 250 kHz

at a change of the ambient temperature from + 25 to + 40 $^{\circ}\text{C}$ (measured after 3 cycles from + 25 to + 55 $^{\circ}\text{C}$)

max. 300 kHz

I.F. circuit characteristics

Bandwidth of i.f. output circuit *

5 MHz

Bandwidth variation of i.f. output circuit as a result of r.f. tuning and bandswitching (reference: v.h.f. III)

max. 350 kHz

Note

I.F. output of the tuner terminated with a modified circuit of Fig. 10, i.e. a 100 pF capacitor is connected in parallel with C1 and R1 is short-circuited; tuning voltage is 15 V.

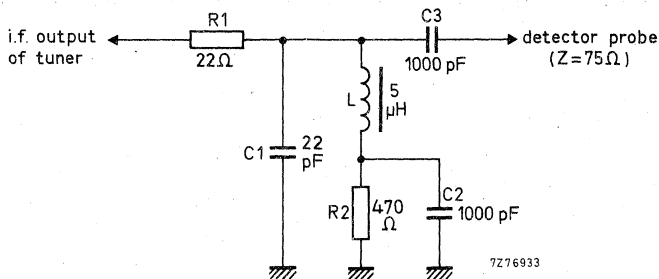

Fig. 10.

* I.F. output of the tuner terminated with the circuit shown in Fig. 10; tuning voltage is 15 V.

Detuning of the i.f. output circuit as
a result of r.f. tuning and bandswitching
(reference; v.h.f. III),
excluded channel E2
channel E2

max. 350 kHz
max. 450 kHz

Note

I.F. output of the tuner terminated with a modified circuit of Fig. 10, i.e. a 100 pF capacitor is connected in parallel with C1 and R1 is short-circuited; tuning voltage is 15 V.

Tuning range of i.f. output coil *

max. 34 to min. 41 MHz

Attenuation between i.f. injection point
and i.f. output of the tuner

typ. 23 dB

Miscellaneous

Radio interference

Oscillator radiation and oscillator
voltage at the aerial terminal

Within the limits of C.I.S.P.R.
24/3 (1970) and VDE 0872/7.72.
For the oscillator radiation above
200 MHz use is made of the relaxed
limit of 2 mV/m (66 dB μ V/m).

Microphonics

There will be no microphonics,
provided the tuner is installed in a
professional manner.

Surge protection

Protection against voltages

max. 8 kV

Note

Three discharges of a 470 pF capacitor into the aerial terminal.

Protection against flashes

max. 30 kV, 400 mWs

Note

A flashover circuit producing flashes with frequencies of 1 to 20 Hz for 30 s is connected to the aerial terminal.

* I.F. output of the tuner terminated with the circuit shown in Fig. 10; tuning voltage is 15 V.

ADDITIONAL INFORMATION

If the tuner is used in receivers designed for v.h.f. only, a capacitor of 5,6 pF should be applied between the aerial input and earth.

I.F. injection

The tuner is provided with an i.f. injection point at the collector of the mixer transistor (coupled via a capacitor to terminal S). The i.f. generator can be connected directly to this point (Fig. 11).

The tuner needs normal supply voltages and a tuning voltage of 15 V; the i.f. output should be loaded with the circuit shown in Fig. 10.

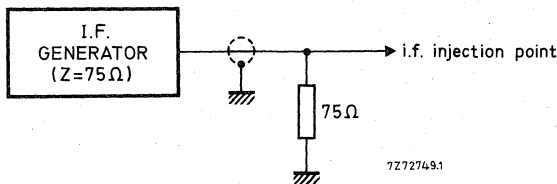

Fig. 11.

Connection of the i.f. amplifier

The tuner needs a d.c. path from the i.f. output terminal (T) to earth, preferably via a choke of approx. 5 μ H outside the tuner (Fig. 12).

In the case where the tuner is used in combination with a u.h.f. tuner, this choke can be common for both tuners; a resistor in series with the choke can make ineffective the i.f. output circuit of the switched off tuner. For damping the i.f. output circuit and matching the i.f. output impedance of the tuner to the i.f. amplifier, a series resistor and a parallel capacitor as shown in Fig. 12 should be used.

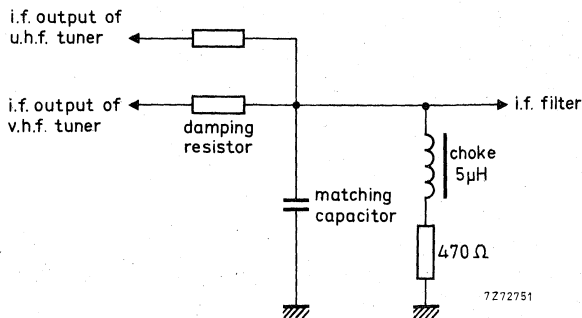

Fig. 12.

Measuring method of power gain

The i.f. output of the tuner should be terminated with the RC-circuit given in Fig. 10.

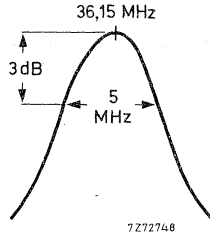

Fig. 13.

The RC-circuit roughly matches the i.f. output impedance to 75Ω at the resonant frequency of the i.f. output circuit, which should be tuned to 36,15 MHz; the bandwidth should be approx. 5 MHz (Fig. 13).

Because the input and output impedances of the tuner are now 75Ω , the power gain can be measured in the conventional manner by inserting tuner and RC-circuit between a 75Ω source and a 75Ω detector.

Alignment of the i.f. output coil

The i.f. output coil should be adjusted with a brass tool with a blade as shown in Fig. 14. A suitable tool is available under catalogue number 7122 009 47680.

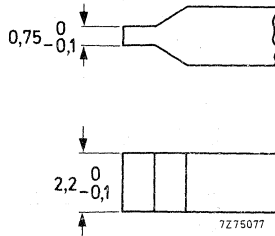

Fig. 14.

ACCESSORIES

Connector assembly for use of tuner V311 in combination with u.h.f. tuner U322:
 connector, catalogue number 3112 200 20720;
 washer, catalogue number 3112 221 01220;
 clamp, catalogue number 3112 274 13220.

V.H.F. TELEVISION TUNERS

QUICK REFERENCE DATA

Systems	C.C.I.R. systems B and G
Channels	
v.h.f. I	E2 to R5
v.h.f. III	S2 to S19
Intermediate frequencies	
picture	38,9 MHz
sound	33,4 MHz

APPLICATION

These tuners are designed to cover the v.h.f. channels of C.C.I.R. systems B and G, including the S channels for cable television.

In combination with the u.h.f. tuner U322, U324, U342 or U342LO respectively, they can be used in v.h.f./u.h.f. receivers. The aerial inputs and i.f. outputs of both tuners can then be connected in parallel without additional circuitry.

The tuners are pin-compatible with tuners V314, V315 and V334.

The V317LO is a special version of the V317: an output voltage from the local oscillator is made available for driving digital tuning systems. Apart from this the tuners are identical.



DESCRIPTION

The tuners are v.h.f. tuners with electronic tuning, covering the v.h.f. band I (47 to 101 MHz) and the v.h.f. band III (111 to 293 MHz). Switching between the bands is done by external band switching.

Mechanically, the tuners are built on a printed-wiring board, carrying all components, in a metal housing made of a rectangular frame and front and rear cover (see Fig. 2a). All connections (aerial, supply voltage, a.g.c. voltage, tuning voltage, i.f. injection, i.f. output) are made via terminals on the underside. The mounting method is shown in Figs 3. Tuner V317LO has a coaxial socket on the top of the frame, for coupling out the oscillator sample.

Electrically the tuner consists of two tunable input circuits in parallel (bands I and III), each followed by an r.f. transistor in grounded-base configuration (BF939 for band I, BF967 for band III). The collector load of each input transistor is formed by a double tuned circuit, transferring the signal to the mixer BF324 fed by the oscillator BF606A. Seven capacitance diodes BB909A tune the double-tuned circuits and the oscillator.

The i.f. output circuit of the tuner is a single tuned one, at the low end of which the i.f. signal is coupled out of the tuner. A d.c. path to earth for the collector current of the mixer has to be provided outside the tuner, preferably by a choke of about $5 \mu\text{H}$. Damping of the i.f. output circuit and matching of the i.f. output to the i.f. circuit of the receiver can be achieved by connecting a series resistance and a parallel capacitance outside the tuner.

An i.f. injection point has been provided at the collector of the mixer transistor, connected to terminal S.

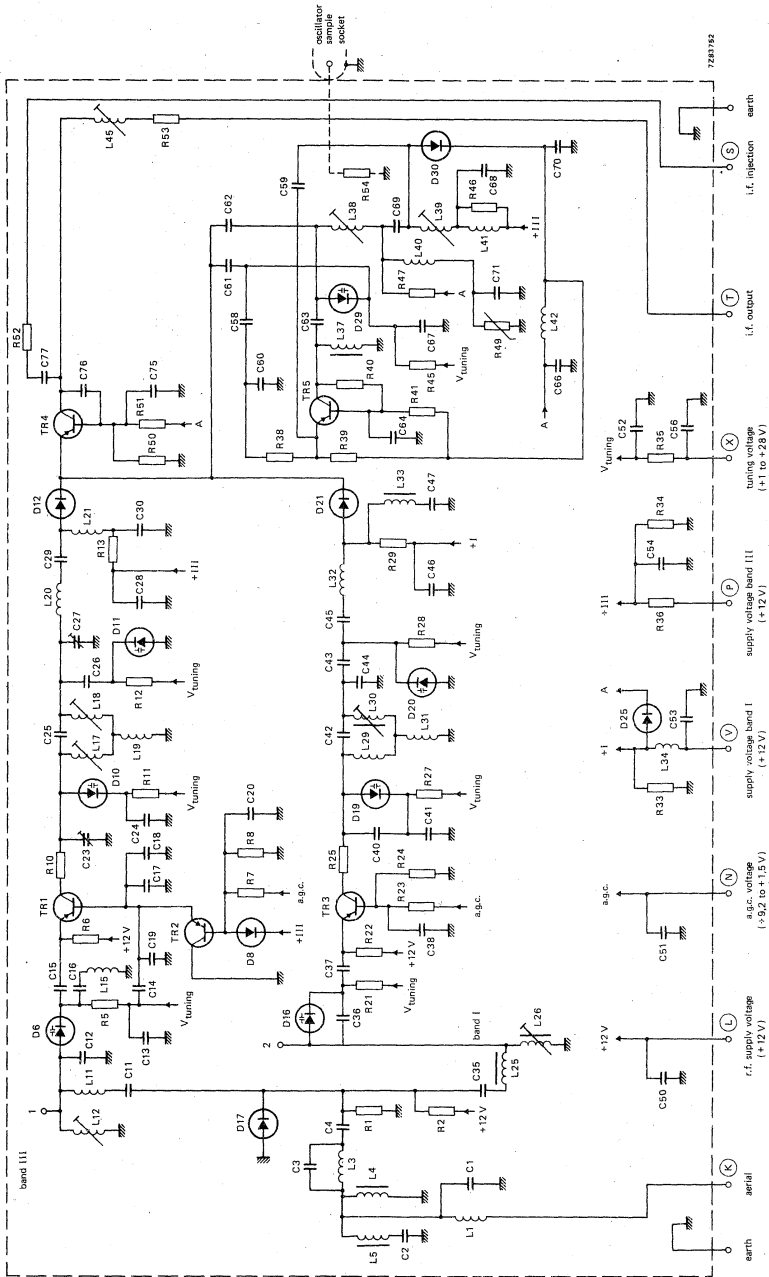

Fig. 1.

MECHANICAL DATA

Dimensions in mm

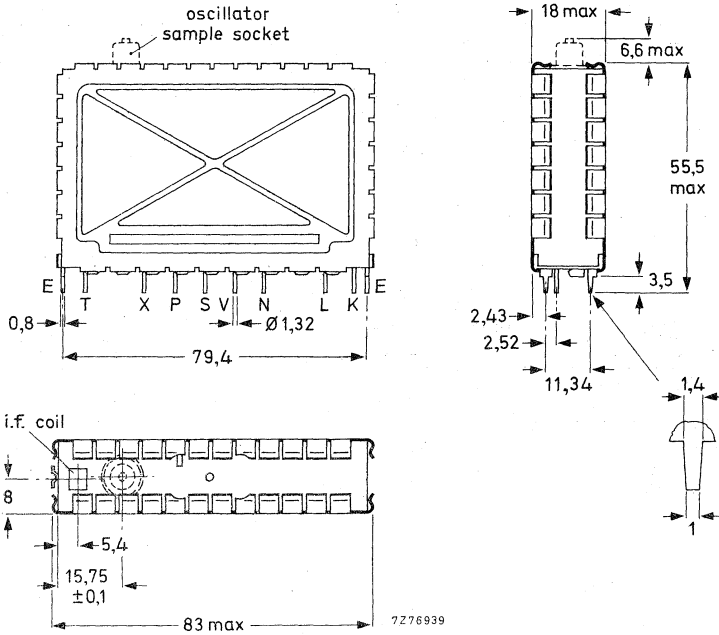

Fig. 2a The oscillator sampling socket, drawn with dotted lines, applies only to tuner V317LO.

Terminal T = i.f. output

X = tuning voltage, +1 to +28 V

P = supply voltage, band III, +12 V

S = i.f. injection point

V = supply voltage, band I, +12 V

N = a.g.c. voltage, +9,2 to 1,5 V

L = r.f. stage supply voltage, +12 V

K = aerial

Note: When the tuner is operated together with a u.h.f. tuner, only the supply voltage at terminals P and V should be switched off during u.h.f. operation.

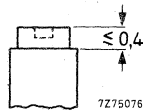

Fig. 2b I.F. output coil,
Torque for alignment: 2 to 15 mNm
Press-through force: ≥ 10 N

Mass

approx. 80 g

Mounting

The tuner may be mounted by soldering it on to a printed-wiring board, using the piercing diagram shown in Fig. 3. (The tuner may also be mounted by means of a socket. Information will be supplied upon request.)

It is recommended that the tuner be installed in the cool part of the receiver cabinet and not exposed to the vibrations of the loudspeaker. There are no restrictions on orientation.

The solderability of the terminals and mounting tabs is according to IEC 68-2, test Ta ($230 \pm 10 \text{ }^\circ\text{C}$, $2 \pm 0,5 \text{ s}$). The resistance to soldering heat is according to IEC 68-2, test Tb ($260 \pm 5 \text{ }^\circ\text{C}$, $10 \pm 1 \text{ s}$).

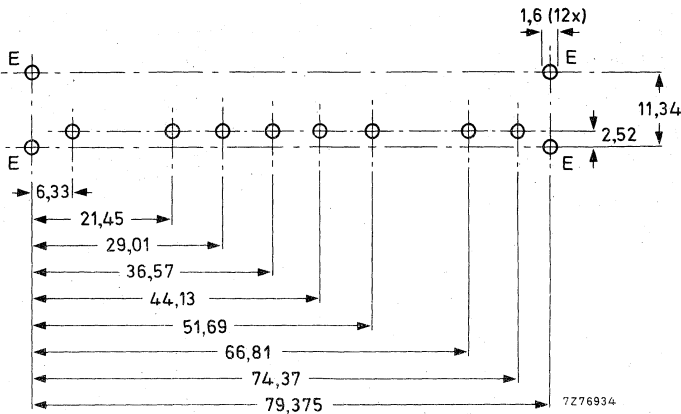

Fig. 3 Piercing diagram viewed from solder side of board.

For connection to the socket on the top of tuner V317LO a coaxial plug has to be used; type 3/2-50 (manufacturer: Daut und Rietz) is recommended.

ELECTRICAL DATA

The electrical values are measured on the v.h.f. tuner alone, but they are also valid for the v.h.f. tuner in combination with a u.h.f. tuner U322, U324, U342 or UL342LO respectively. Unless otherwise specified all electrical values apply at an ambient temperature of $25 \pm 5^\circ\text{C}$, a relative humidity of $60 \pm 15\%$, a supply voltage of $12 \pm 0,3\text{ V}$ and an a.g.c. voltage of $9,2 \pm 0,2\text{ V}$.

Within the given tolerance range of supply voltage and a.g.c. voltage only insignificant deviations from the specified values can be expected. Under the extreme conditions of temperature and humidity as given below, the tuner will function normally, but some specified limits may be exceeded.

General

Semiconductors

r.f. amplifier, band I	BF939
r.f. amplifier, band III	BF967
mixer	BF324
oscillator	BF606A
tuning diodes	7 x BB909A or BB709
switching diodes	BA244; BA482; BA483; BA220; 2 x BA317
switching transistor	BC558

Ambient temperature range

operating	+5 to +55 °C
storage	-25 to +70 °C

Relative humidity

max. 90%

Voltages and currents

Supply voltage	+12 V \pm 10%
----------------	-----------------

Note: The supply voltage at terminals P and V should be filtered.

Current drawn from +12 V supply

r.f. amplifier, v.h.f. I, at nominal gain	typ. 12 mA
v.h.f. I, at 40 dB gain reduction	typ. 20 mA
r.f. amplifier, v.h.f. III, at nominal gain	typ. 10 mA
v.h.f. III, at 40 dB gain reduction	typ. 20 mA
mixer and oscillator	typ. 12 mA

Band switching

For operation in band I the supply voltage must be connected to terminal V, for band III operation to terminal P. If the tuner operates together with a u.h.f. tuner only the supply voltage at terminals P and V should be switched off during u.h.f. operation.

A.G.C. voltage (Figs 4 and 5)

at nominal gain

+9,2 ± 0,5 V

at 40 dB gain reduction

min. +1,5 V

Note: A.G.C. voltages between 0 and +10 V may be applied without risk of damage.

A.G.C. current (Figs 6 and 7)

during gain control (0 to 40 dB)

max. +1,0 mA

min. -2,0 mA

at nominal gain

typ. +0,8 mA

at 40 dB gain reduction

typ. -1,2 mA

Tuning voltage range (Figs 8 and 9)

+1 to +28 V

Current drawn from +28 V tuning voltage supply

at 25 °C

max. 350 nA

at 55 °C

max. 1,5 μA

Note: The source impedance of the tuning voltage offered to terminal X must be max. 47 kΩ.

Switching current

max. 16 mA

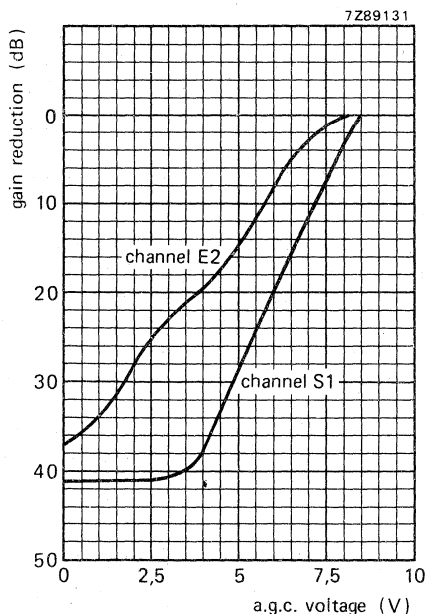

Fig. 4 Typical a.g.c. voltage characteristic, channels E2 and S1.

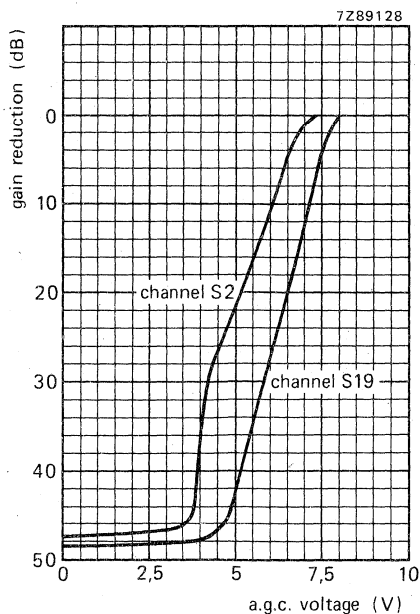

Fig. 5 Typical a.g.c. voltage characteristic, channels S2 and S19.

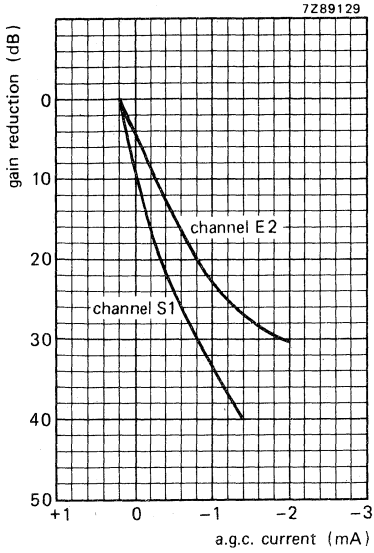

Fig. 6 Typical a.g.c. current characteristic, channels E2 and S1.

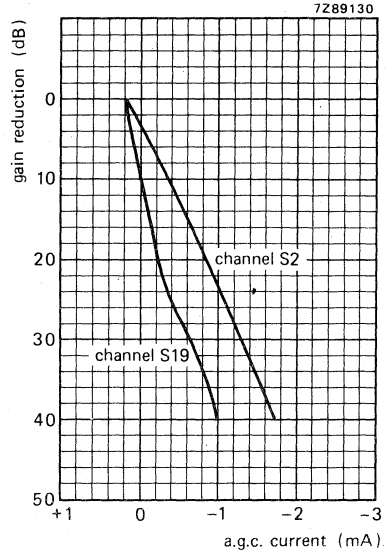

Fig. 7 Typical a.g.c. current characteristic, channels S2 and S19.

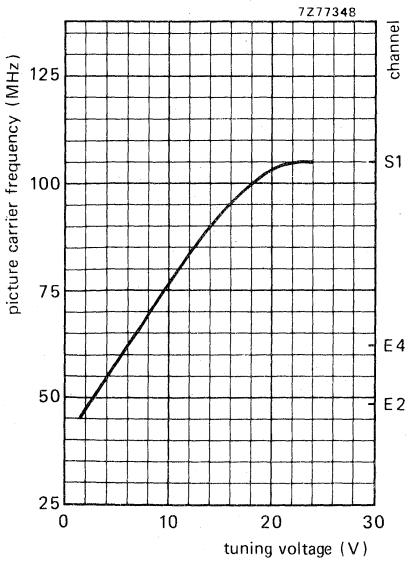

Fig. 8 Typical tuning voltage characteristic, v.h.f. I.

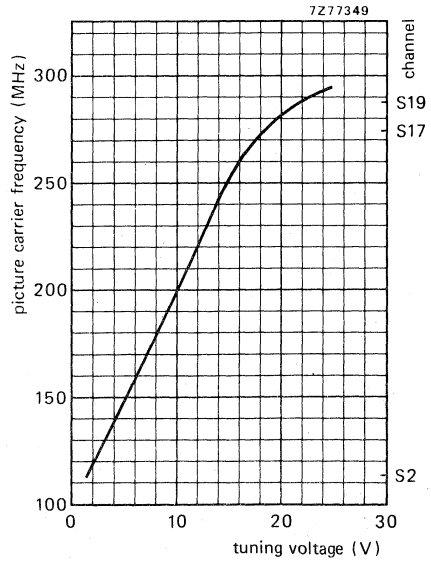

Fig. 9 Typical tuning voltage characteristic, v.h.f. III.

Oscillator sample signal; only valid for V317LO

At a supply voltage of +10,8 to +13,2 V, an operating temperature of +5 to +55 °C, and within the tuning voltage range +0,5 to +30 V

typ.	84 dB (μ V) into 75 Ω
min.	80 dB (μ V) into 75 Ω
max.	104 dB (μ V) into 75 Ω

Note: A tuning voltage higher than +28 V will not be harmful for the tuner and may be applied at the user's own risk. Under this condition the published reverse voltage limit of the oscillator tuning diode will be exceeded; the oscillator frequency will never decrease with increasing tuning voltage.

Frequency of oscillator sample signal; only valid for V317LO

v.h.f. I	87,15 to 132,15 MHz
v.h.f. III	151,15 to 326,15 MHz

Frequencies**Frequency ranges**

v.h.f. I	channel E2 (picture carrier 48,25 MHz) to channel R5 (picture carrier 93,25 MHz). Margin at the extreme channels: min. 2 MHz.
v.h.f. III	channel S2 (picture carrier 112,25 MHz) to channel S19 (picture carrier 287,25 MHz). Margin at the extreme channels: min. 2 MHz.

Intermediate frequencies

picture	38,9 MHz
sound	33,4 MHz
	The oscillator frequency is higher than the aerial signal frequency.

Wanted signal characteristics**Input impedance**

asymmetrical	75 Ω
--------------	-------------

Output impedance at the oscillator sample socket; only valid for V317LO

asymmetrical	75 Ω
--------------	-------------

V.S.W.R. and reflection coefficient

	minimum value between picture carrier and sound carrier frequency	maximum value at picture carrier frequency
v.s.w.r.	max. 4	max. 4
reflection coefficient	max. 60%	max. 60%

V.S.W.R. and reflection coefficient at oscillator sample socket; only valid for V317LO

v.s.w.r., v.h.f. I	max. 2
v.s.w.r., v.h.f. III	max. 2
reflection coefficient, v.h.f. I	max. 33%
reflection coefficient, v.h.f. III	max. 33%

R.F. curves, bandwidth	typ. 12 MHz
R.F. curves, tilt	on any channel the amplitude difference between the top of the r.f. resonant curve and the picture carrier marker, the sound carrier marker, or any frequency between them will not exceed 3 dB at nominal gain, and 4 dB in the a.g.c. range between nominal gain and 20 dB gain reduction.
A.G.C. range, except channels E2, E3 and E4	min. 40 dB
A.G.C. range, channels E2 and E3	min. 30 dB
channel E4	min. 35 dB
Power gain (see also Measuring method of power gain)	min. 20 dB
channel E3	typ. 27 dB
channel E5	typ. 26 dB
channel E12	typ. 28 dB
Gain difference between any two channels	typ. 6 dB
Noise figure	max. 10 dB
channel E3	typ. 5,5 dB
channel E5	typ. 8 dB
channel E12	typ. 8 dB
Overloading	
Input signal producing 1 dB gain compression at nominal gain	to be established
Input signal producing either a detuning of the oscillator of +300 kHz or -1000 kHz or stopping of the oscillations at nominal gain	typ. 90 dB (μ V) into 75 Ω
Unwanted signal characteristics	
Image rejection (measured at picture carrier frequency)	
channels E2 to E12	min. 60 dB
channels S11 to S19	min. 53 dB
I.F. rejection (measured at picture carrier frequency), except channel E2	min. 60 dB
channel E2	min. 50 dB
Note: At colour sub-carrier frequency max. 6 dB less rejection.	
Harmonic content of oscillator sample; only valid for V317LO	
Suppression of harmonics which fall into the frequency range below 1000 MHz	min. 15 dB below oscillator fundamental
R.F. rejection at oscillator sample socket; only valid for V317LO	
Signal voltage at oscillator sample socket (input signals of wanted frequency 70 dB (μ V) into 75 Ω , tuner operating at nominal gain)	min. 20 dB below oscillator fundamental
I.F. rejection at oscillator sample socket; only valid for V317LO	
I.F. signals at oscillator sample socket (input signals of wanted frequency 70 dB (μ V) into 75 Ω , tuner operating at nominal gain)	min. 20 dB below oscillator fundamental

Cross modulation

Input signal producing 1% cross modulation, i.e. 1% of the modulation depth of the interfering signal is transferred to the wanted signal.

In channel cross modulation (wanted signal: picture carrier frequency; interfering signal: sound carrier frequency)

at nominal gain (wanted input level 60 dB (μ V) typ. 70 dB (μ V) into 75 Ω
at 40 dB gain reduction (wanted input level 100 dB (μ V) typ. 100 dB (μ V) into 75 Ω

In band cross modulation (wanted signal: picture carrier of channel N; interfering signal: picture carrier of channel N \pm 2 for v.h.f. I or channel N \pm 3 for v.h.f. III)

at nominal gain (wanted input level 60 dB (μ V) typ. 86 dB (μ V) into 75 Ω
at 40 dB gain reduction (wanted input level 100 dB (μ V) typ. 100 dB (μ V) into 75 Ω

Out of band cross modulation at nominal gain

v.h.f. I, interfering from v.h.f. III typ. 100 dB (μ V) into 75 Ω
v.h.f. I, interfering from u.h.f. typ. 100 dB (μ V) into 75 Ω
v.h.f. III, interfering from v.h.f. I typ. 100 dB (μ V) into 75 Ω
v.h.f. III, interfering from u.h.f. typ. 110 dB (μ V) into 75 Ω

Oscillator characteristics**Pulling**

Input signal of tuned frequency producing

a shift of the oscillator frequency of
10 kHz, at nominal gain

v.h.f. I typ. 75 dB (μ V) into 75 Ω
v.h.f. III typ. 75 dB (μ V) into 75 Ω

Shift of oscillator frequency at a change
of the supply voltage of 5%

max. 250 kHz

Drift of oscillator frequency during warm-up time
(after the tuner has been completely out of operation for 15 min; measured between 5 s and 15 min after switching on)

max. 250 kHz

during warm-up time (after the input stage is in operation for 15 min; measured between 2 s and 15 min after switching on the self-oscillating mixer stage)

max. 250 kHz

at a change of the ambient temperature from +25 to +40 $^{\circ}$ C (measured after 3 cycles from +25 to +60 $^{\circ}$ C)

channels S1 to S16

typ. 250 kHz

channels S17 to S19

max. 400 kHz
max. 550 kHz



I.F. circuit characteristics

Bandwidth of i.f. output circuit 5,9 ± 0,5 MHz

Note: I.F. output of the tuner terminated with the circuit shown in Fig. 10; tuning voltage is 15 V; band III at minimum gain.

Bandwidth variation of i.f. output circuit
as a result of r.f. tuning and band
switching (reference: v.h.f. III) max. 350 kHz

Note: I.F. output of the tuner terminated with a modified circuit of Fig. 10, i.e. a 100 pF capacitor is connected in parallel with the i.f. output of the tuner; tuning voltage is 15 V.

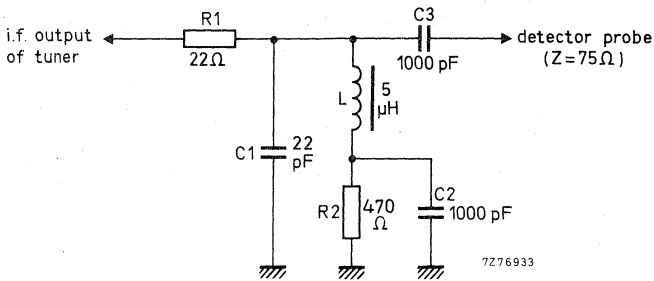

Fig. 10.

Detuning of the i.f. output circuit as a
result of r.f. tuning in band III max. 350 kHz

Note: I.F. output of the tuner terminated with a modified circuit of Fig. 10, i.e. a 100 pF capacitor is connected in parallel with the i.f. output of the tuner; tuning voltage is 15 V.

Minimum tuning range of i.f. output coil 34 to 41 MHz

Note: I.F. output of the tuner terminated with the circuit shown in Fig. 10; tuning voltage is 15 V.

Attenuation between i.f. injection point
and i.f. output of the tuner 23 ± 3 dB

Miscellaneous

Radio interference

Oscillator radiation and oscillator voltage
at the aerial terminal

Within the limits of C.I.S.P.R. 13
(1975) and VDE0872/7.72*.

* For V317LO: when the oscillator sample socket is either open or terminated with a coaxial plug (75 Ω impedance, e.g. type 3/2-50, Daut und Rietz).

Microphonics

There will be no microphonics, provided the tuner is installed in a professional manner.

Surge protection

Protection against voltages

max. 5 kV

Note: Three discharges of a 470 pF capacitor into the aerial terminal.

Protection against flashes

max. 30 kV, 400 mWs

Note: A flashover circuit producing flashes with frequencies of 1 to 20 Hz for 30 s is connected to the aerial terminal.

ADDITIONAL INFORMATION

I.F. injection

The tuner is provided with an i.f. injection point at the collector of the mixer transistor (coupled via a capacitor and a resistor to terminal S). The i.f. generator can be connected directly to this point (Fig. 11).

The tuner needs normal supply voltages and a tuning voltage of 15 V; the i.f. output should be loaded with the circuit shown in Fig. 10.

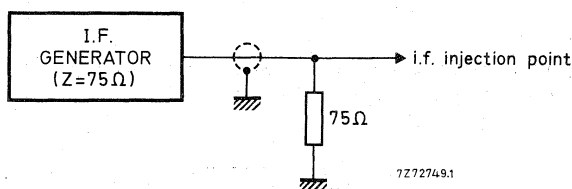

Fig. 11.

Connection of the i.f. amplifier

The tuner needs a d.c. path from the i.f. output terminal (T) to earth, preferably via a choke of approx. $5\ \mu\text{H}$ outside the tuner (Fig. 12). Where the tuner is used in combination with a u.h.f. tuner, this choke can be common for both tuners; a resistor in series with the choke can make ineffective the i.f. output circuit of the switched-off tuner. For damping the i.f. output circuit and matching the i.f. output impedance of the tuner to the i.f. amplifier, a series resistor and a parallel capacitor as shown in Fig. 12 should be used (During v.h.f. operation the voltage across the $470\ \Omega$ resistor is 1 to 1,2 V).

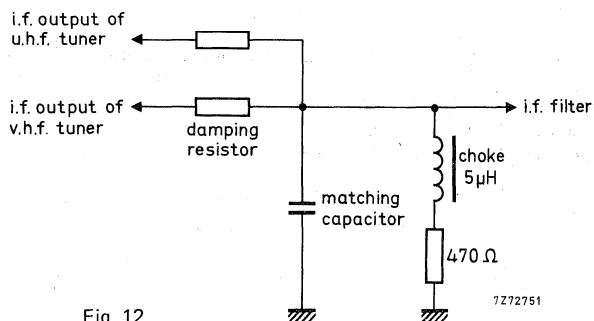

Fig. 12.

Measuring method of power gain

The i.f. output of the tuner should be terminated with the RC-circuit given in Fig. 10.

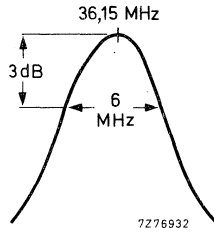

Fig. 13.

The RC-circuit roughly matches the i.f. output impedance to 75Ω at the resonant frequency of the i.f. output circuit, which should be tuned to 36,15 MHz; the bandwidth should be approx. 6 MHz (Fig. 13).

Because the input and output impedances of the tuner are now 75Ω , the power gain can be measured in the conventional manner by inserting tuner and RC-circuit between a 75Ω source and a 75Ω detector.

Alignment of the i.f. output coil

The i.f. output coil should be adjusted with a brass tool with a blade as shown in Fig. 14. A suitable tool is available under catalogue number 7122 005 47680.

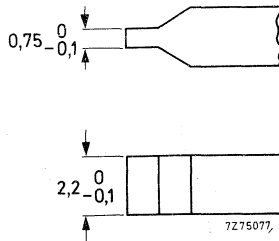

Fig. 14.

ACCESSORIES

Connector assembly for use of tuner V317 or V317LO in combination with u.h.f. tuner U342 or U342LO:

- connector, catalogue number 3112 200 20720;
- washer, catalogue number 3112 221 01220;
- clamp, catalogue number 3112 274 13220.

V.H.F. TELEVISION TUNERS

QUICK REFERENCE DATA

Systems	C.C.I.R. systems B and G
Channels	
v.h.f. I	NZ1 to C
v.h.f. III	M4 to E12
Intermediate frequencies	
picture	38,9 MHz
sound	33,4 MHz

APPLICATION

These tuners are designed to cover the v.h.f. channels of C.C.I.R. systems B and G, including the Italian and Moroccan channels.

In combination with the u.h.f. tuner U322, U324, U342 or U342LO respectively, they can be used in v.h.f./u.h.f. receivers. The aerial inputs and i.f. outputs of both tuners can then be connected in parallel without additional circuitry.

The tuners are pin-compatible with tuners V314, V315 and V317.

The V334LO is a special version of the V334; an output voltage from the local oscillator is made available for driving digital tuning systems. Apart from this the tuners are identical.



DESCRIPTION

The tuners are v.h.f. tuners with electronic tuning, covering the v.h.f. band I (44 to 88 MHz) and the v.h.f. band III (162 to 230 MHz). Switching between the bands is done by connecting the supply voltage to terminal V for band I and to terminal P for band III.

Mechanically, the tuner is built on a printed-wiring board, carrying all components, in a metal housing made of a rectangular frame and front and rear cover (see Fig. 2a). All connections (aerial, supply voltage, a.g.c. voltage, tuning voltage, i.f. injection, i.f. output) are made via terminals on the underside. The mounting method is shown in Fig. 3. Tuner V334LO has a coaxial socket on the top of the frame for coupling out the oscillator sample.

Electrically the tuner consists of two input circuits in parallel (bands I and III) with band-pass characteristics, switchable for band I and band III, followed by a MOS-FET amplifier stage. The drain load of the MOS-FET is formed by a double tuned circuit, transferring the signal to the self-oscillating mixer BF967. The selectivity of this circuit at the intermediate frequency has been improved. Three capacitance diodes BB109G (or BB809) tune the double tuned circuit and the oscillator.

The i.f. output circuit of the tuner is a single tuned one, at the low end of which the i.f. signal is coupled out of the tuner. A d.c. path to earth for the collector current of the mixer has to be provided outside the tuner, preferably by a choke of about 5 μ H. Damping of the i.f. output circuit and matching of the i.f. output to the i.f. circuit of the receiver can be achieved by connecting a series resistance and a parallel capacitance outside the tuner.

An i.f. injection point has been provided at the collector of the mixer transistor, connected to terminal S.



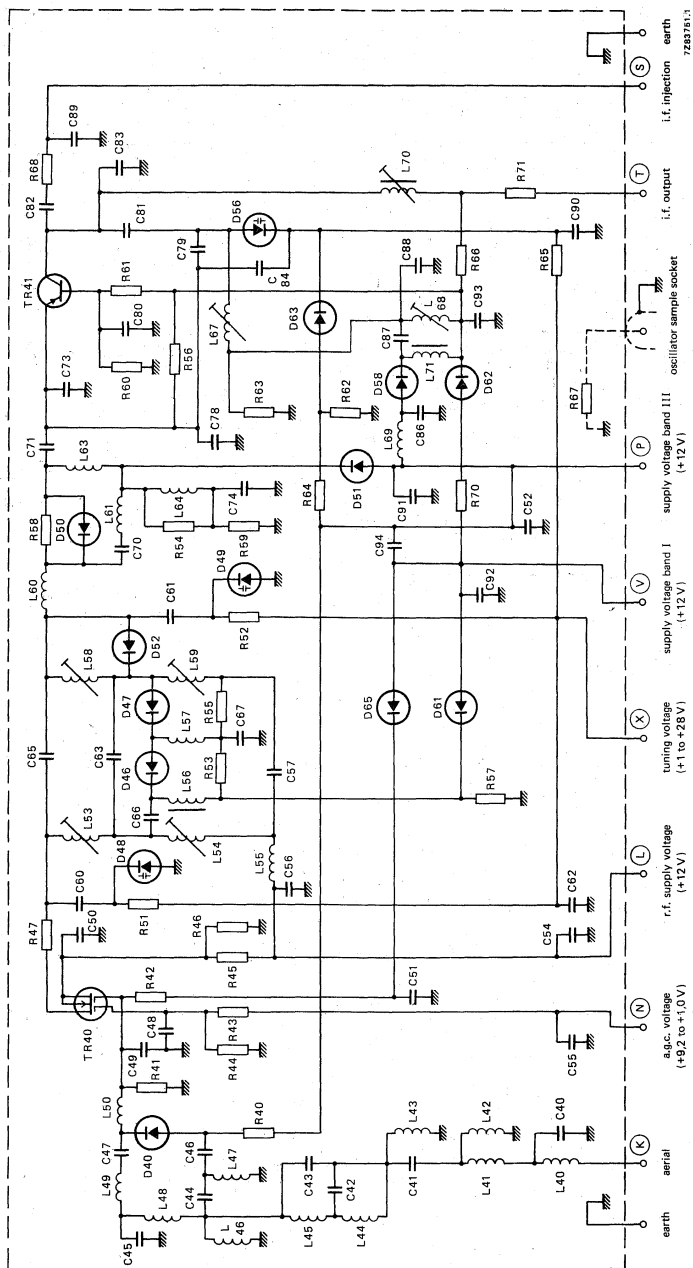

Fig. 1.

MECHANICAL DATA

Dimensions in mm

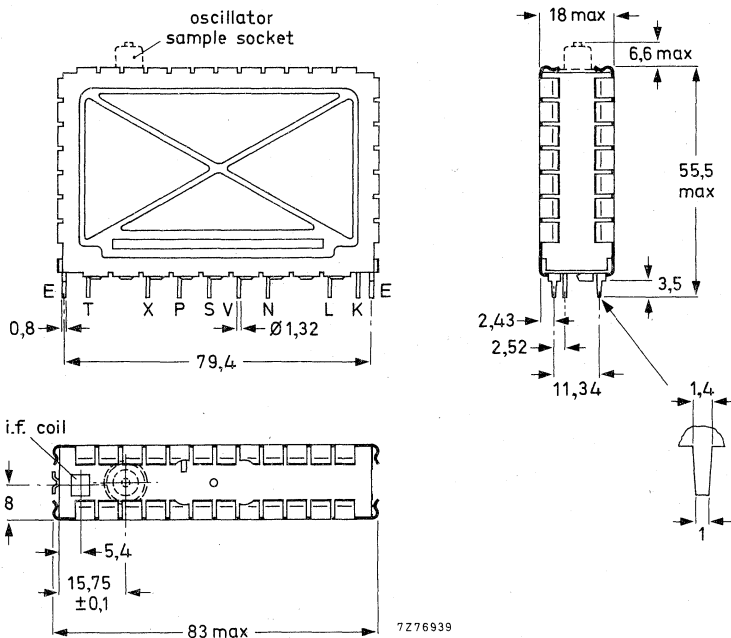

Fig. 2a The oscillator sampling socket, drawn with dotted lines, applies only to tuner V334LO.

- Terminal T = i.f. output
- X = tuning voltage, +1 to +28 V
- P = supply voltage, band III, +12 V
- S = i.f. injection point
- V = supply voltage, band I, +12 V
- N = a.g.c. voltage, +9,2 to +1,0 V
- L = r.f. stage supply voltage, +12 V
- K = aerial

Note: When the tuner is operated together with a u.h.f. tuner, only the supply voltage at terminals P and V should be switched off during u.h.f. operation.

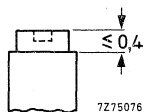

Fig. 2b I.F. output coil.
Torque for alignment: 2 to 15 mNm
Press-through force: ≥ 10 N

Mass

approx. 80 g

Mounting

The tuner may be mounted by soldering it on to a printed-wiring board, using the piercing diagram shown in Fig. 3. (The tuner may also be mounted by means of a socket. Information will be supplied upon request).

It is recommended that the tuner be installed in the cool part of the receiver cabinet and not exposed to the vibrations of the loudspeaker. There are no restrictions on orientation.

The solderability of the terminals and mounting tabs is according to IEC 68-2, test Ta ($230 \pm 10^\circ\text{C}$, $2 \pm 0,5$ s). The resistance to soldering heat is according to IEC 68-2, test Tb ($260 \pm 5^\circ\text{C}$, 10 ± 1 s).

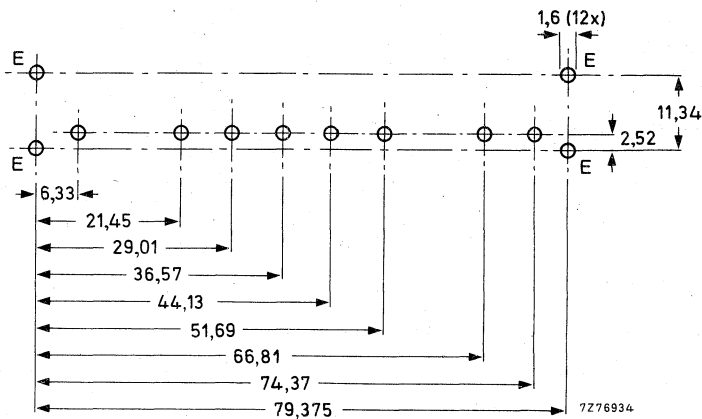

Fig. 3 Piercing diagram viewed from solder side of board.

For connection to the socket on the top of tuner V334LO a coaxial plug has to be used; type 3/2-50 (manufacturer: Daut und Rietz) is recommended.

ELECTRICAL DATA

The electrical values are measured on the v.h.f. tuner alone*, but they are also valid for the v.h.f. tuner in combination with a u.h.f. tuner U322, U324, U342 or U342LO respectively. Unless otherwise specified all electrical values apply at an ambient temperature of $25 \pm 5^\circ\text{C}$, a relative humidity of $60 \pm 15\%$, a supply voltage of $12 \pm 0,3\text{ V}$ and an a.g.c. voltage of $9,2 \pm 0,2\text{ V}$.

Within the given tolerance range of supply voltage and a.g.c. voltage only insignificant deviations from the specified values can be expected. Under the extreme conditions of temperature and humidity as given below, the tuner will function normally, but some specified limits may be exceeded.

General

Semiconductors

r.f. amplifier	BF961
self-oscillating mixer	BF967
tuning diodes	3 x BB109G (or BB809)
switching diodes	6 x BA482/BA483, 3 x BA220, 2 x BA318

Ambient temperature range

operating	+5 to +55 °C
storage	-25 to +70 °C

Relative humidity

max. 90%

Voltages and currents

Supply voltage	+12 V \pm 10%
----------------	-----------------

Note: The supply voltage at terminals P and V should be filtered.

Current drawn from +12 V supply

r.f. amplifier, v.h.f. I, at nominal gain	typ. 25 mA
v.h.f. I, at 40 dB gain reduction	typ. 13,5 mA
r.f. amplifier, v.h.f. III, at nominal gain	typ. 25 mA
v.h.f. III, at 40 dB gain reduction	typ. 15 mA
self-oscillating mixer, terminal P	typ. 12,0 mA
terminal V	typ. 12,5 mA

Band switching

For operation in band I the supply voltage must be connected to terminal V, for band III operation to terminal P. If the tuner operates together with a u.h.f. tuner only the supply voltage at terminals P and V should be switched off during u.h.f. operation.

* All measurements on the tuner alone are done with a capacitor of 6,8 pF between aerial and earth.

A.G.C. voltage (Figs 4 to 7)

at nominal gain

+9,2 ± 0,5 V

at 40 dB gain reduction

min. +1,0 V

Note: A.G.C. voltages between 0 and + 10 V may be applied without risk of damage.

A.G.C. current

during gain control (0 to 40 dB)

max. +1,0 mA

at nominal gain

typ. +0,8 mA

at 40 dB gain reduction

typ. -0,2 mA

Tuning voltage range (Figs 8 and 9)

+1 to +28 V

Current drawn from + 28 V tuning voltage supply

at 25 °C

max. 150 nA

at 55 °C

max. 600 nA

Note: The source impedance of the tuning voltage offered to terminal X must be maximum 47 kΩ.

Switching current

max. 18 mA

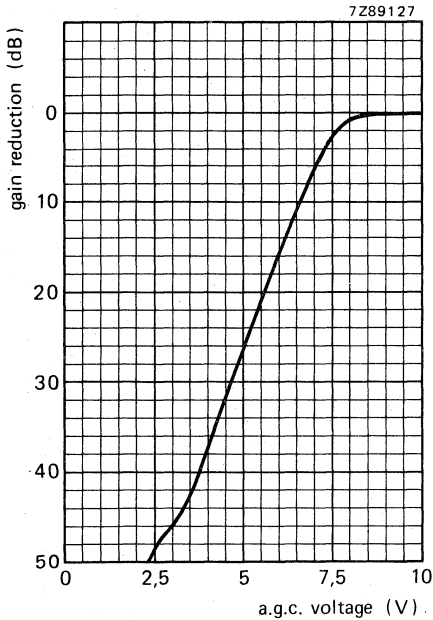

Fig. 4 Typical a.g.c. voltage characteristic, channel NZ1.

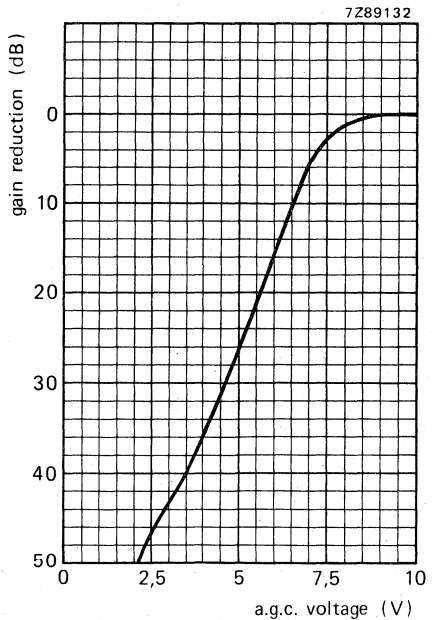

Fig. 5 Typical a.g.c. voltage characteristic, channel E4.

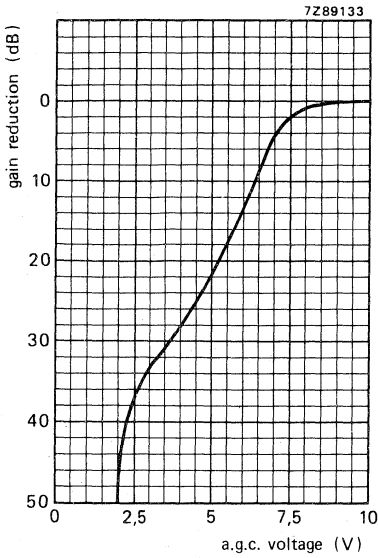

Fig. 6 Typical a.g.c. voltage characteristic, channel E5.

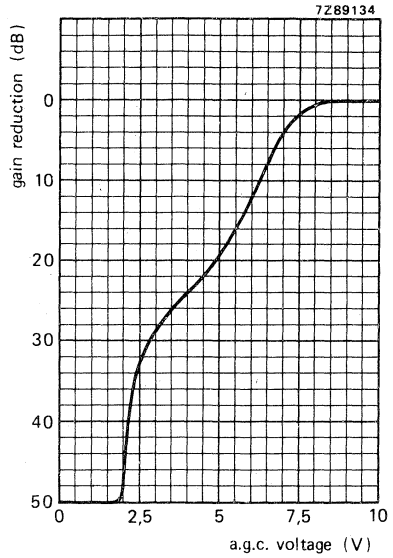

Fig. 7 Typical a.g.c. voltage characteristic, channel E12.

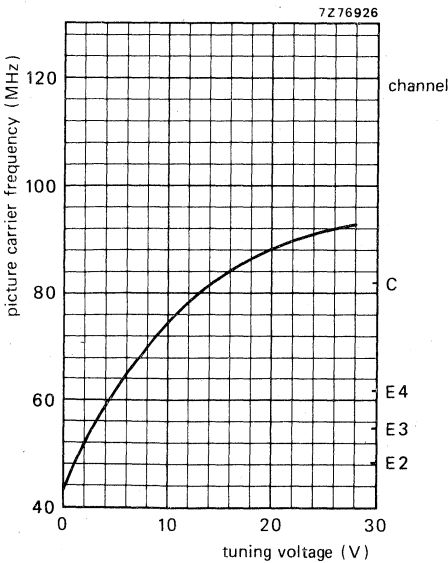

Fig. 8 Typical tuning voltage characteristic, v.h.f. I.

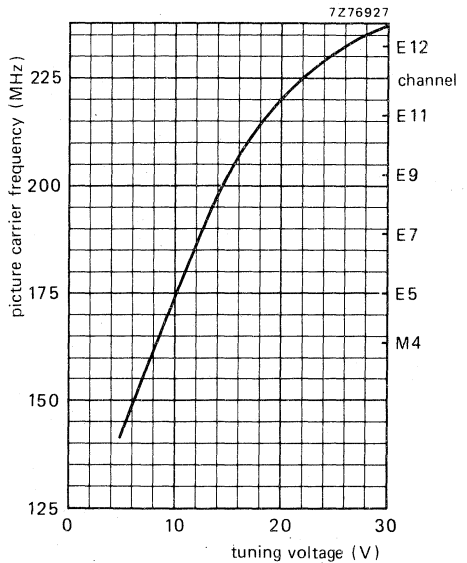

Fig. 9 Typical tuning voltage characteristic, v.h.f. III.

Oscillator sample signal; **only valid for V334LO**

At a supply voltage of +10,8 to +13,2 V, an operating temperature of +5 to +55 °C, and within the tuning voltage range +0,5 to +30 V

typ. 84 dB (μ V) into 75 Ω
min. 80 dB (μ V) into 75 Ω
max. 104 dB (μ V) into 75 Ω

Note: A tuning voltage higher than +28 V will not be harmful for the tuner and may be applied at the user's own risk. Under this condition the published reverse voltage limit of the oscillator tuning diode will be exceeded; the oscillator frequency will never decrease with increasing tuning voltage.

Frequency of oscillator sample signal; **only valid for V334LO**

v.h.f. I 84,15 to 121,15 MHz
v.h.f. III 202,15 to 263,15 MHz

Frequencies

Frequency ranges

v.h.f. I channel NZ1 (picture carrier 45,25 MHz) to channel C (picture carrier 82,25 MHz)
Margin at the extreme channels: min. 2 MHz.
v.h.f. III channel M4 (picture carrier 163,25 MHz) to channel E12 (picture carrier 224,25 MHz)
Margin at the extreme channels: min. 2 MHz.

Intermediate frequencies

picture 38,9 MHz
sound 33,4 MHz
The oscillator frequency is higher than the aerial signal frequency

Wanted signal characteristics

Input impedance

asymmetrical 75 Ω

Output impedance at the oscillator sample socket; **only valid for V334LO**

asymmetrical 75 Ω

V.S.W.R. and reflection coefficient

	minimum value between picture carrier and sound carrier frequency	maximum value at picture carrier frequency
--	--	--

v.s.w.r.	max. 4	max. 4
reflection coefficient	max. 60%	max. 60%

V.S.W.R. and reflection coefficient at oscillator sample socket; **only valid for V334LO**

v.s.w.r., v.h.f. I	max. 2
v.s.w.r., v.h.f. III	max. 2
reflection coefficient, v.h.f. I	max. 33%
reflection coefficient, v.h.f. III	max. 33%

R.F. curves, bandwidth	typ. 12 MHz
R.F. curves, tilt	on any channel the amplitude difference between the top of the r.f. resonant curve and the picture carrier marker, the sound carrier marker, or any frequency between them will not exceed 3 dB at nominal gain, and 4 dB in the a.g.c. range between nominal gain and 20 dB gain reduction.
A.G.C. range	min. 40 dB
Power gain (see also Measuring method of power gain)	min. 20 dB
channel E3	typ. 23 dB
channel E5	typ. 24 dB
channel E12	typ. 24 dB
Gain difference between any two channels	typ. 6 dB
Noise figure	max. 9 dB
channel E3	typ. 6 dB
channel E5	typ. 7,5 dB
channel E12	typ. 8 dB

Overloading

Input signal producing 1 dB gain compression at nominal gain	typ. 80 dB (μ V) into 75 Ω
Input signal producing either a detuning of the oscillator of +300 kHz or -1000 kHz or stopping of the oscillations at nominal gain	typ. 90 dB (μ V) into 75 Ω

Unwanted signal characteristics

Image rejection (measured at picture carrier frequency), except channel M4	min. 60 dB
channel M4	min. 48 dB
I.F. rejection (measured at picture carrier frequency), except channels NZ1 and E2	min. 60 dB
channel NZ1	min. 40 dB
channel E2	min. 50 dB

Note: At colour sub-carrier frequency maximum 6 dB less rejection.

Harmonic content of oscillator sample; only valid for V334LO

Suppression of harmonics which fall into the frequency range below 1000 MHz min. 15 dB below oscillator fundamental

R.F. rejection at oscillator sample socket; only valid for V334LO

Signal voltage at oscillator sample socket (input signals of wanted frequency 70 dB (μ V) into 75 Ω , tuner operating at nominal gain) min. 15 dB below oscillator fundamental

I.F. rejection at oscillator sample socket; only valid for V334LO

I.F. signals at oscillator sample socket (input signals of wanted frequency 70 dB (μ V) into 75 Ω , tuner operating at nominal gain) min. 15 dB below oscillator fundamental

Cross modulation

Input signal producing 1% cross modulation, i.e. 1% of the modulation depth of the interfering signal is transferred to the wanted signal.

In channel cross modulation (wanted signal: picture carrier frequency; interfering signal: sound carrier frequency):

at nominal gain (wanted input level 60 dB (μ V))	
v.h.f. I	typ. 70 dB (μ V) into 75 Ω
v.h.f. III	typ. 67 dB (μ V) into 75 Ω
at 40 dB gain reduction (wanted input level 100 dB (μ V))	
	typ. 100 dB (μ V) into 75 Ω

In band cross modulation (wanted signal: picture carrier of channel N; interfering signal: picture carrier of channel N \pm 2 for v.h.f. I or channel N \pm 3 for v.h.f. III)

at nominal gain (wanted input level 60 dB (μ V))	typ. 88 dB (μ V) into 75 Ω
at 40 dB gain reduction (wanted input level 100 dB (μ V))	typ. 100 dB (μ V) into 75 Ω

Out of band cross modulation at nominal gain

v.h.f. I, interfering from v.h.f. III	typ. 110 dB (μ V) into 75 Ω
v.h.f. I, interfering from u.h.f.	typ. 110 dB (μ V) into 75 Ω
v.h.f. III, interfering from v.h.f. I	typ. 110 dB (μ V) into 75 Ω
v.h.f. III, interfering from u.h.f.	typ. 110 dB (μ V) into 75 Ω

Oscillator characteristics**Pulling**

Input signal of tuned frequency producing a shift of the oscillator frequency of 10 kHz, at nominal gain

v.h.f. I	typ. 73 dB (μ V) into 75 Ω
v.h.f. III	typ. 69 dB (μ V) into 75 Ω

Shift of oscillator frequency at a

change of the supply voltage of 5%	max. 250 kHz
------------------------------------	--------------

Drift of oscillator frequency

during warm-up time (after the tuner has been completely out of operation for 15 min, measured between 5 s and 15 min after switching on)	max. 250 kHz
---	--------------

during warm-up time (after the input stage is in operation for 15 min, measured between 2 s and 15 min after switching on the self-oscillating mixer stage.)	max. 250 kHz
--	--------------

at a change of the ambient temperature from +25 to +40 $^{\circ}$ C (measured after 3 cycles from +25 to +55 $^{\circ}$ C)	max. 300 kHz
--	--------------



I.F. circuit characteristics

Bandwidth of i.f. output circuit

$5,8 \pm 0,5$ MHz

Note: I.F. output of the tuner terminated with the circuit shown in Fig. 10; tuning voltage is 15 V; band III at minimum gain.

Bandwidth variation of i.f. output circuit as a result of r.f. tuning and band switching (reference: v.h.f. III)

max. 500 kHz

Note: I.F. output of the tuner terminated with a modified circuit of Fig. 10, i.e. a 100 pF capacitor is connected in parallel with the i.f. output of the tuner; tuning voltage is 15 V.

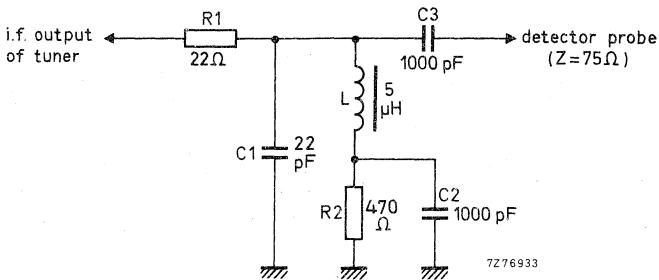

Fig. 10.

Detuning of the i.f. output circuit as a result of r.f. tuning and band switching (reference: v.h.f. III)

max. 350 kHz

Note: I.F. output of the tuner terminated with a modified circuit of Fig. 10, i.e. a 100 pF capacitor is connected in parallel with the i.f. output of the tuner; tuning voltage is 15 V.

Minimum tuning range of i.f. output coil

34 to 41 MHz

Note: I.F. output of the tuner terminated with the circuit shown in Fig. 10; tuning voltage is 15 V.

Attenuation between i.f. injection point and i.f. output of the tuner

typ. 23 dB

Miscellaneous

Radio interference

Oscillator radiation and oscillator voltage at the aerial terminal

Within the limits of C.I.S.P.R. 13 (1975) and VDE 0872/7.72*.

Microphonics

There will be no microphonics, provided the tuner is installed in a professional manner.

Surge protection

Protection against voltages

max. 5 kV

Note: Three discharges of a 470 pF capacitor into the aerial terminal.

Protection against flashes

max. 30 kV, 400 mWs

Note: A flashover circuit producing flashes with frequencies of 1 to 20 Hz for 30 s is connected to the aerial terminal.

ADDITIONAL INFORMATION

If the tuner is used in receivers designed for v.h.f. only, a capacitor of 6,8 pF should be applied between the aerial input and earth.

I.F. injection

The tuner is provided with an i.f. injection point at the collector of the mixer transistor (coupled via a capacitor and a resistor to terminal S). The i.f. generator can be connected directly to this point. (Fig. 11).

The tuner needs normal supply voltages and a tuning voltage of 15 V; the i.f. output should be loaded with the circuit shown in Fig. 10.

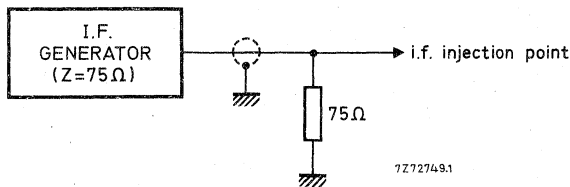

Fig. 11.

* For V334LO: when the oscillator sample socket is either open or terminated with a coaxial plug (75 Ω impedance, e.g. type 3/2-50, Daut und Rietz).

Connection of the i.f. amplifier

The tuner needs a d.c. path from the i.f. output terminal (T) to earth, preferably via a choke of approx. $5\ \mu\text{H}$ outside the tuner (Fig. 12). Where the tuner is used in combination with a u.h.f. tuner, this choke can be common for both tuners; a resistor in series with the choke can make ineffective the i.f. output circuit of the switched off tuner. For damping the i.f. output circuit and matching the i.f. output impedance of the tuner to the i.f. amplifier, a series resistor and a parallel capacitor as shown in Fig. 12 should be used. (During v.h.f. operation the voltage across the $470\ \Omega$ resistor is 1 to 1,2 V).

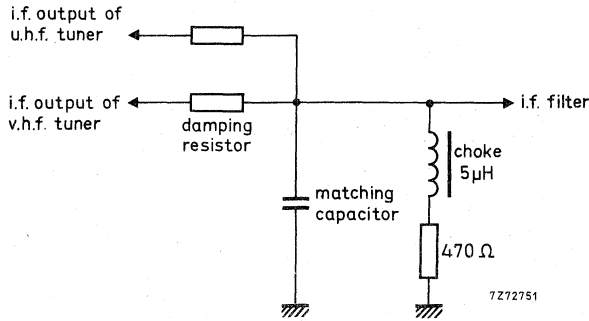

Fig. 12.

Measuring method of power gain

The i.f. output of the tuner should be terminated with the RC-circuit given in Fig. 10.

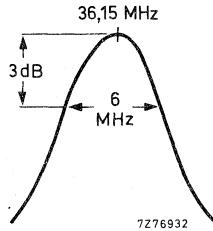

Fig. 13.

The RC-circuit roughly matches the i.f. output impedance to $75\ \Omega$ at the resonant frequency of the i.f. output circuit, which should be tuned to $36,15\ \text{MHz}$; the bandwidth should be approx. $6\ \text{MHz}$ (Fig. 13). Because the input and output impedances of the tuner are now $75\ \Omega$, the power gain can be measured in the conventional manner by inserting tuner and RC-circuit between a $75\ \Omega$ source and a $75\ \Omega$ detector.

Alignment of the i.f. output coil

The i.f. output coil should be adjusted with a brass tool with a blade as shown in Fig. 14. A suitable tool is available under catalogue number 7122 005 47680.

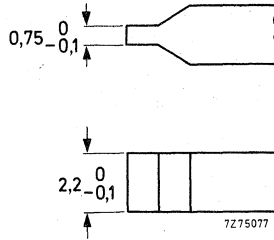

Fig. 14.

ACCESSORIES

Connector assembly for use of tuner V334 to V334LO in combination with u.h.f. tuner U342 or U342LO;

connector, catalogue number 3112 200 20720;

washer, catalogue number 3112 221 01220;

clamp, catalogue number 3112 274 13220.



V.H.F. TELEVISION TUNER

with diode tuning

QUICK REFERENCE DATA

Systems	Systems E, L and L'	
Channels	System E	Systems L and L'
v.h.f. I	F2, F4	A to C
v.h.f. III	F5 to F12	1 to 6
Intermediate frequencies		
picture	32.70	32.70 MHz
sound	43.85	39.20 MHz

APPLICATION

This tuner covers the v.h.f. channels of systems E, L and L'. In combination with the u.h.f. tuner UF5, it can be used in v.h.f./u.h.f. television receivers. The aerial inputs and i.f. outputs of both tuners can be connected in parallel without additional circuitry.



DESCRIPTION

The VF5 is a v.h.f. television tuner with electronic tuning, covering the v.h.f. band I and the v.h.f. band III. Switching between the bands is done by external switching.

The tuner circuit is built on a printed wiring board, and enclosed in a metal housing, comprising a rectangular frame with front and rear covers (see Fig. 2).

A shielded aerial lead is fitted to one of the shorter sides of the frame, all other connections (supply-input stage, a.g.c., tuning voltage, switching voltages, i.f. input from u.h.f. tuner, supply for oscillator and i.f. stage, and i.f. output) are made via terminals in the underside. Mounting as in Fig. 3.

Electrically the tuner consists of two input circuits in parallel (band I and band III) with band-pass characteristics and has the input transistor connected in grounded-base configuration. This transmitter operates at an emitter current of about 4 to 12 mA, featuring good noise figures and good signal handling properties. This combination has good handling properties throughout the a.g.c. range. The collector load of the input transistor is formed by a double tuned circuit, transferring the signal to the self-oscillating mixer. 3-variable capacitance diodes tune the double tuned circuits and the oscillator.

The i.f. output signal is extracted from the low end of the single-tuned output circuit.

A d.c. path to earth for the collector current of the mixer is provided inside the tuner.

An i.f. injection point is provided. Access is through a hole in the cover.



CIRCUIT DIAGRAM

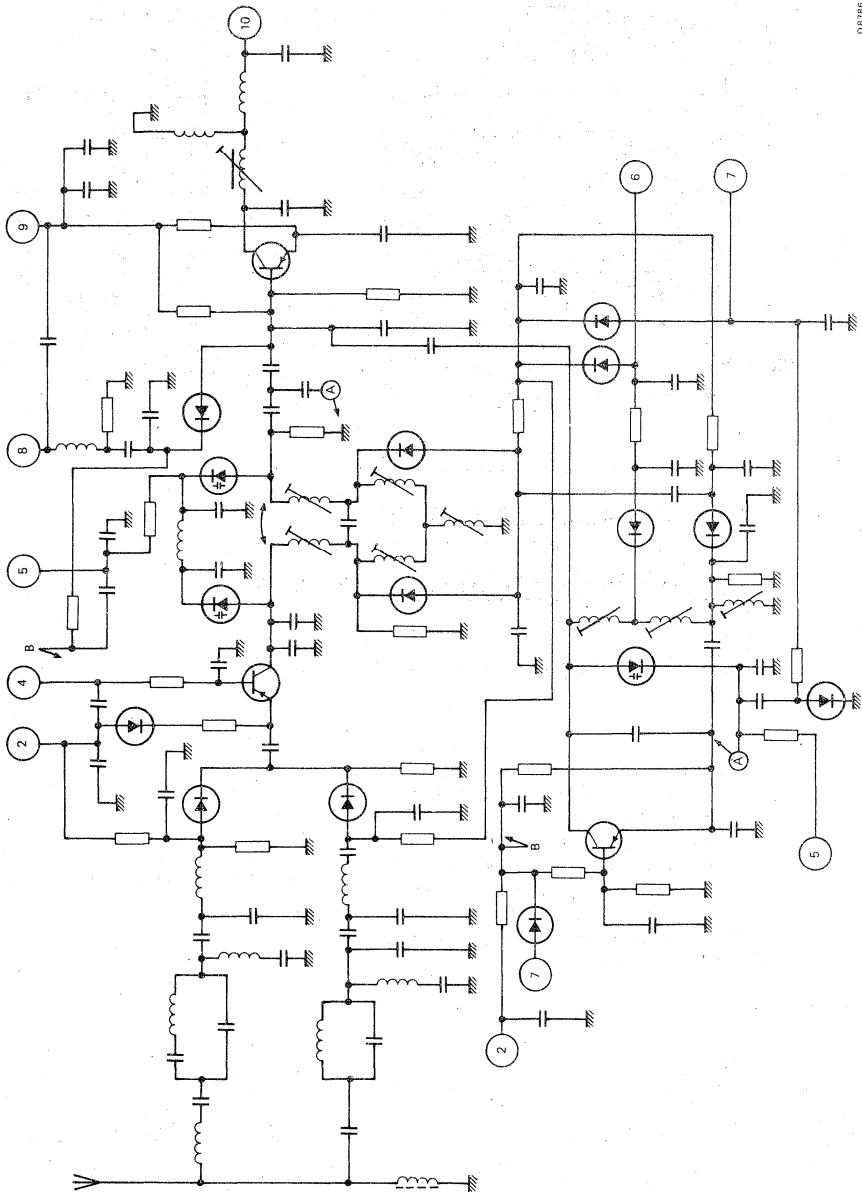

Fig. 1.

08786

08786
08786
08786
08786
08786
08786

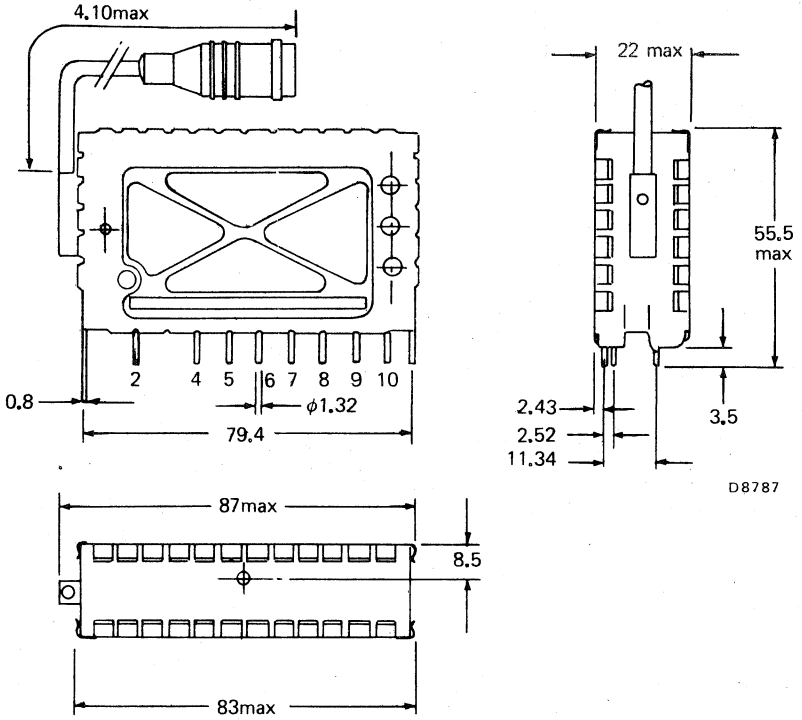

Fig.2

- 2 = r.f. stage supply voltage +12 V
- 4 = a.g.c. voltage
- 5 = tuning voltage +0.4 to +28 V
- 6 = Band III inverted (even channels)
- 7 = Band III normal (odd channels)
- 8 = i.f. input from u.h.f. tuner
- 9 = oscillator/i.f. supply voltage +12 V
- 10 = i.f. output

Switching voltage +12 V

Mass approx. 75 g

Mounting

The tuner may be mounted by soldering it on to a printed-wiring board, with connections as shown by the piercing diagram in Fig. 3. (The tuner may also be mounted in a socket. Information will be supplied upon request).

It is recommended that the tuner be installed in a cool part of the receiver cabinet and not exposed to the vibrations of the loudspeaker. There are no restrictions on orientation.

The solderability of the terminals and mounting tabs is according to IEC 68-2, test Ta (230 ± 10 °C, 2 ± 0.5 s). The resistance to soldering heat is according to IEC 68-2, test Tb (260 ± 5 °C, 10 ± 1 s).

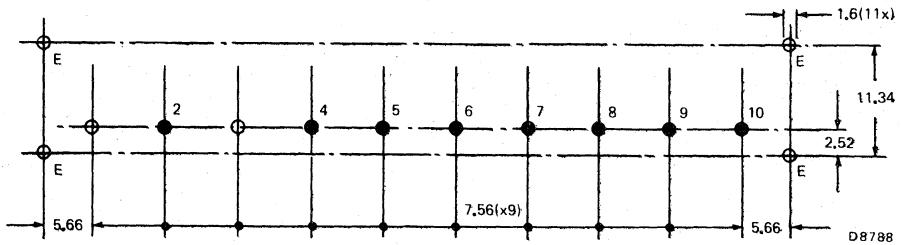

Fig. 3 Piercing diagram viewed from solder side of board

ELECTRICAL DATA

The electrical values are measured on the v.h.f. tuner alone, but they are also valid for the v.h.f. tuner when used with the u.h.f. tuner UF5. Unless otherwise specified all electrical values apply at an ambient temperature of 25 ± 5 °C, a relative humidity of $60 \pm 15\%$ and a supply voltage of 12 ± 0.1 V. Under the extreme conditions of temperature and humidity given below, the tuner will function normally, but some specified limits may be exceeded.

General

Ambient temperature range	
operating	+5 to +55 °C
storage	-25 to +85 °C
Relative humidity	max. 90%

Voltages and currents

Supply voltage	
positive	12 V \pm 1 V
negative (negligible current)	-12 V \pm 1 V
Current drawn from 12 V supply v.h.f. III at max. gain	typ. 38 mA
A.G.C. voltage	
at nominal gain	+9 V
at 40 dB gain reduction	band I 2.5 V band III 5.5 V
Tuning voltage range	+0.4 to +28 V
Current drawn from 28 V tuning voltage supply	0.5 μ A

Frequencies

Range of frequencies

		System E		Systems L and L'		
	channel	vision	sound	channel	vision	sound
Band I	F2	52.4 MHz	41.25 MHz	A to C	47.75 MHz	41.25 MHz
	F4	65.55 MHz	54.40 MHz		63.75 MHz	57.25 MHz
Band III normal (odd channels)	F5 to F11	164.00 MHz 203.45 MHz	175.15 MHz 214.60 MHz	1 to 6	176.00 MHz 216.00 MHz	182.50 MHz 222.50 MHz
	Band III inverted (even channels)	F6 to F12	173.40 MHz 212.85 MHz	162.25 MHz 201.70 MHz	— —	— —

Intermediate frequencies

picture
sound

System E

System L and L'

32.7 MHz
43.85 MHz

32.7 MHz
39.2 MHz

The oscillator frequency may be higher or lower than the aerial signal frequency depending on the channel frequency and system.

Wanted signal characteristics

Input impedance
asymmetrical

75 Ω

V.S.W.R.

max. 4

Reflection coefficient

max. 60%

R.F. curves, bandwidth

 ≤ 20 MHz

R.F. curves, tilt
(only for i.f. 32.7/43.85)

On any channel the amplitude difference between the top of the r.f. resonant curve and the picture carrier marker, the sound carrier or any frequency between them will not exceed 2.5 dB

Power gain

band I
band III

 ≥ 19 dB ≥ 21 dB

Noise figure

band I
band III

 ≤ 8 dB ≤ 8 dB

Unwanted signal characteristics

Image rejection		
band I		≥ 60 dB
band III normal		
channel 6 (L')		≥ 36 dB
other channels		≥ 50 dB
band III inverted		
channels 6 to 10		≥ 40 dB
other channels		≥ 50 dB

I.F. rejection		
band III		≥ 60 dB
band I		see table below

		frequency		
system	channel	32.7 MHz	39.2 MHz	43.85 MHz
E	F2	-28 dB		+5 dB
	F4	-33 dB		-4 dB
L'	A	-28 dB	+5 dB	
	B	-30 dB	-3 dB	
	C	-36 dB	-9 dB	

Maximum signal handling		
bands I and III		≥ 5 dBmV

U.H.F. i.f. input signal handling		≥ 23 dBmV
-----------------------------------	--	-----------

Oscillator characteristics

Shift of oscillator frequency at a change		
of ambient temperature of 15 °C (+25 to +40 °C)		≤ 400 kHz

R.F./I.F. characteristics

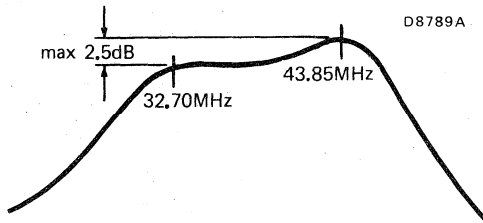

Tuning peak vision	32.70 MHz
Tuning peak sound (system E)	43.85 MHz
Tuning peak sound (system L')	39.20 MHz

Miscellaneous

Radio interference

Oscillator radiation at
the aerial terminal

(a) fundamental frequency	band I	≤ -54 dBm
	band III	≤ -49 dBm
(b) harmonic frequencies	$F_h < 300$ MHz	≤ -59 dBm
	$F_h > 300$ MHz and < 1000 MHz	≤ -57 dBm

Microphony

There will be no microphonics, providing that the tuner is installed in a professional manner.



COAXIAL AERIAL INPUT ASSEMBLIES

APPLICATION

These coaxial aerial input assemblies have been developed for application in television sets with 75 ohm input impedance, for use in v.h.f. as well as in u.h.f. (40-890 MHz). The connectors meet the demands of both the IEC standards (diameter 9,5 mm) and the French standards (diameter 9,0 mm). They have to be used with plugs complying with the properties mentioned in DIN 45325, IEC 169-2 (diameter 9,5 mm) and SNIR (diameter 9,0 mm). The units meet the safety requirements of IEC 65.

AVAILABLE TYPES

Coaxial aerial input assembly 75 Ω

Attenuation	: ≤ 1 dB
Reflection, v. h. f.	: ≤ 15%
u. h. f.	: ≤ 25%
Catalogue number	: 3122 127 10260

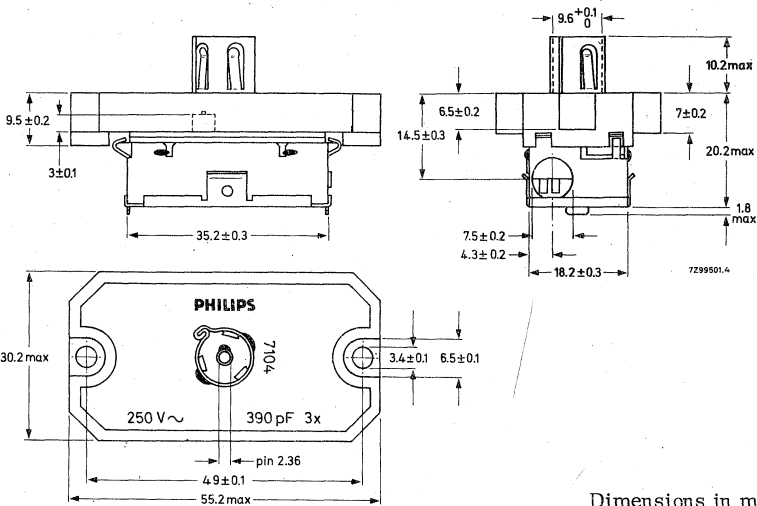
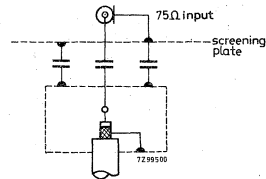

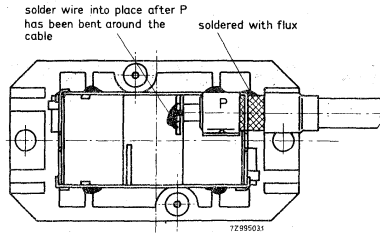

Recommended fixing of the aerial cable
 Soldering conditions : 370 ± 5 °C; $3,5 \pm 0,5$ s

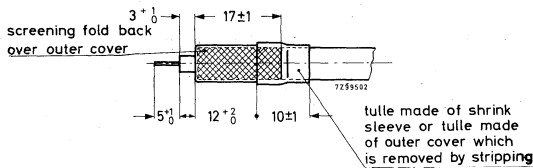

Cable diameter ≥ 5 mm

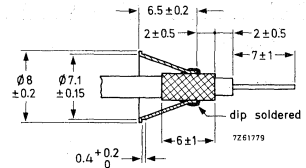

Cable diameter < 5 mm

Coaxial aerial input assembly 75 Ω, with filter

Reflection, v. h. f.	≤ 25%
u. h. f.	≤ 30%
Frequency characteristic	
v. h. f., 50 to 230 MHz	≤ 1 dB
470 MHz	≥ 13 dB
700 MHz	23 dB (typical value)
u. h. f., 470 to 850 MHz	≤ 1 dB
230 MHz	≥ 15 dB
100 MHz	40 dB (typical value)
Catalogue number	3122 127 10450

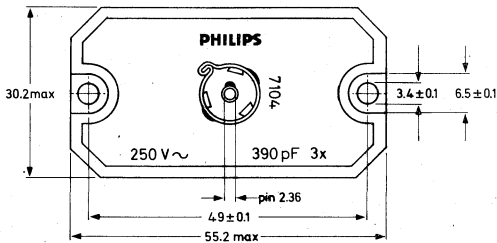
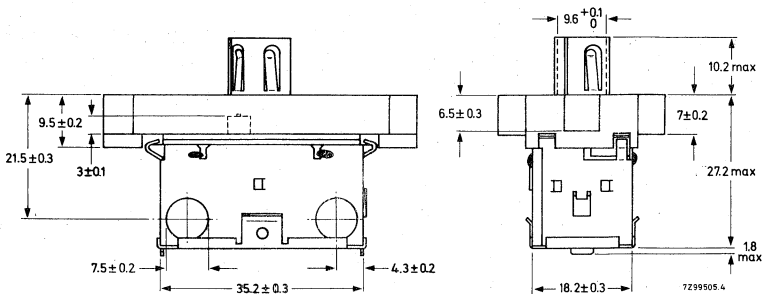
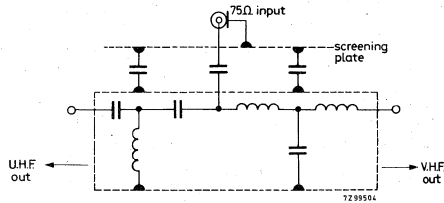

Dimensions in mm



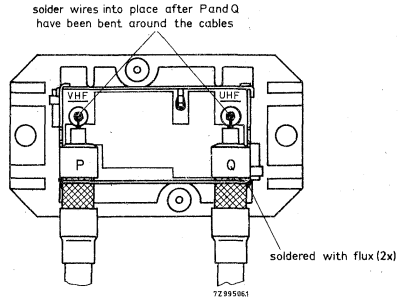

Recommended fixing of the aerial cable
 Soldering conditions: 370 ± 5 °C; $3,5 \pm 0,5$ s

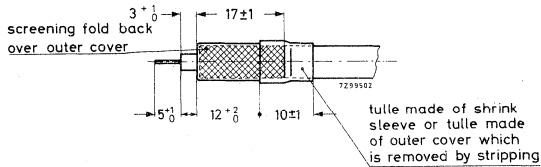

Cable diameter ≥ 5 mm

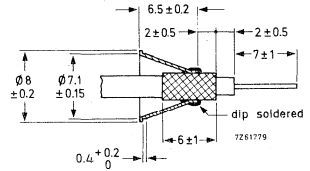

Cable diameter < 5 mm

Coaxial aerial input assembly 75 Ω, with high-pass filter

Attenuation at 1 MHz : 60 dB (typical value)
 5 MHz : 40 dB (typical value)
 10 MHz : ≥ 25 dB
 50 MHz : ≤ 1 dB
 230 MHz : ≤ 1 dB
 470 MHz : ≤ 1 dB
 850 MHz : ≤ 1,5 dB

Reflection, v. h. f. I : ≤ 35%
 v. h. f. III : ≤ 15%
 u. h. f. : ≤ 35%

Catalogue number : 3122 127 14730

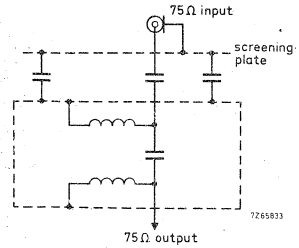

Dimensions in mm

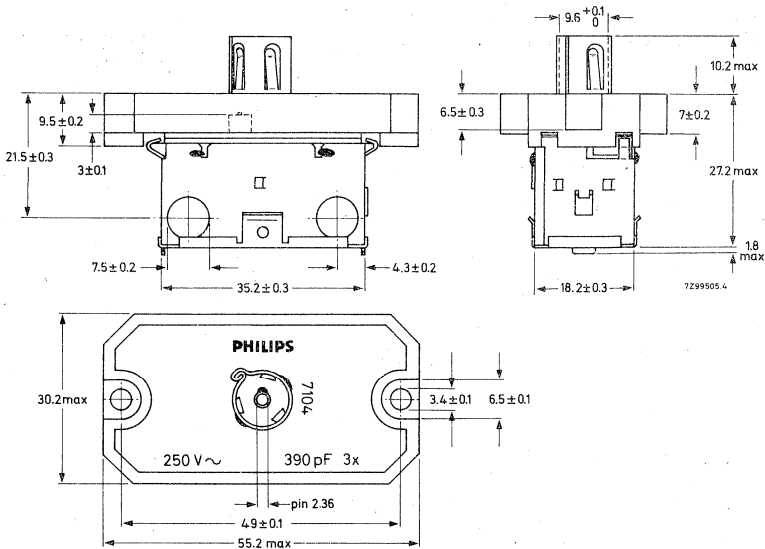

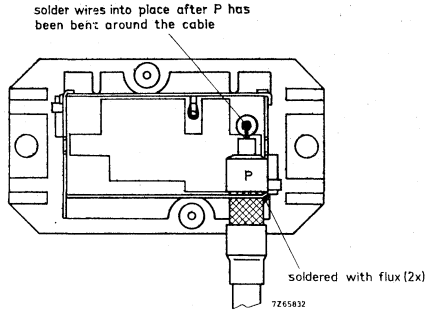

Recommended fixing of the aerial cable
 Soldering conditions : 370 ± 5 °C; $3,5 \pm 0,5$ s

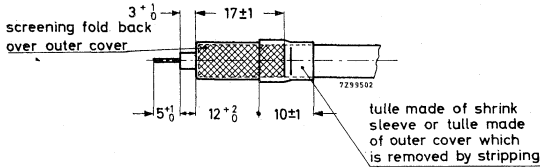

Cable diameter ≥ 5 mm

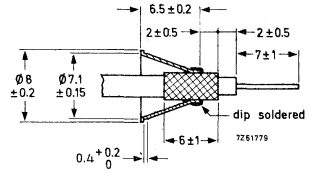

Cable diameter < 5 mm

COAXIAL AERIAL INPUT ASSEMBLY

APPLICATION

This coaxial aerial input assembly has been developed for application in TV sets with 75Ω input impedance, for use in v.h.f. as well as in u.h.f. bands. Thanks to the use of safety capacitors in the assembly, the chassis of the TV set is separated from the aerial input. The connector for the aerial input meets the demands of the IEC standards (diameter 9,5 mm) and the French standards (diameter 9,0 mm).

The coaxial aerial input assembly complies with the requirements of immunity from radiated interference of BS 905. It meets the safety requirements of IEC 65; approbation approvals have been sought from KEMA, VDE, SEV, BSI, DEMKO, NEMKO, SEMKO, EI and LCEE.

DESCRIPTION

The assembly is provided with safety capacitors, which are moulded in thermo-setting insulation material, thus forming a capacitor block. This capacitor block is built in a metal housing, with lid, which is carried by a plastic fixing plate. All points to the safety capacitors are press contacts, achieved by the metal housing. The housing has an outlet for the coaxial cable to the television tuner.

ELECTRICAL DATA

The electrical values are measured at an ambient temperature of $25 \pm 5 \text{ }^\circ\text{C}$ and a relative humidity of $60 \pm 15\%$.

Input impedance of connector	75 Ω , asymmetrical
Frequency ranges	
v.h.f.	40 to 300 MHz
u.h.f.	470 to 890 MHz
Reflection	
v.h.f.	$\leq 15\%$
u.h.f.	$\leq 25\%$
Insertion loss	
v.h.f.	$\leq 1 \text{ dB}$; typ. 0,2 dB
u.h.f.	$\leq 1 \text{ dB}$; typ. 0,4 dB
Contact resistance of connector	
after 1 plug insertion	
inner bush	$\leq 10 \text{ m}\Omega$
outer bush	$\leq 5 \text{ m}\Omega$
Insulation resistance	$> 500 \text{ M}\Omega$
Immunity from radiated interference	in conformity with requirements of BS 905, provided the assembly is installed in a professional manner, and a proper coaxial cable is used.

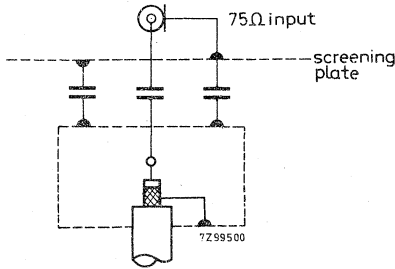

Fig. 1.

ENVIRONMENTAL DATA

Operating temperature range	0 to $+55 \text{ }^\circ\text{C}$
Storage temperature range	-40 to $+85 \text{ }^\circ\text{C}$
Relative humidity	$\leq 95\%$

MECHANICAL DATA

Dimensions in mm

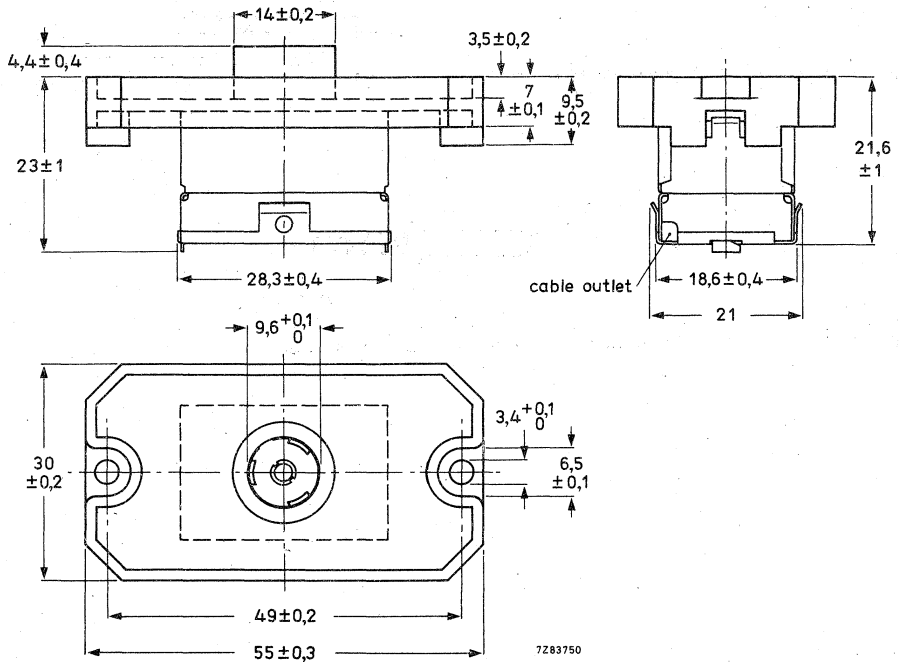

Fig. 2.

MOUNTING

The assembly can be mounted to the chassis of the TV set with two self-tapping screws, 4N x 9,5.

It must be connected to the tuner via a coaxial cable with a diameter of 3 mm. The inner cable conductor should be soldered to the metal plating of the capacitor block, and the cable earth sheath to the metal housing, see Fig. 3.

The soldering conditions are: 340 °C, 2 s.

Plugs to be used with the assembly have to comply with the properties mentioned in DIN 45325, IEC 69-2 (9,5 mm diameter) and SNIR (9 mm diameter).

It is advised not to use aluminium plugs.

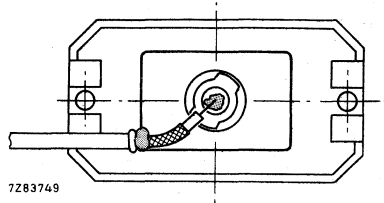

Fig. 3 Recommended fixing of the aerial cable.

7283749

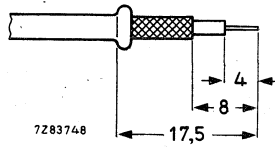

Fig. 4 Recommended cable stripping.

7283748



VIDEO MODULATORS



VIDEO MODULATORS

QUICK REFERENCE DATA

	REMO 101	REMO 201
C.C.I.R. system	G	I
Channels	E30 to E40	E30 to E40
Inter-carrier sound frequency	5,5 MHz	6 MHz

APPLICATION

These video modulators are for use in:

- video tape recorders (VCR);
- TV cameras;
- video games;
- video information systems;
- closed circuit TV video systems.

DESCRIPTION

In the video modulator, video and sound signals are modulated onto a u.h.f. carrier. The modulated carrier at the output is suited for connection to the antenna socket of normal television receivers. The carrier frequency can be adjusted from 540 to 624 MHz (channel E30 to channel E40) so 10 different channels can be linked via a single coaxial cable.

The modulators meet the radiation requirements of C.I.S.P.R. Recommendation No. 13.

Mechanically, the modulators are built on a low-loss printed-wiring board, carrying all components, in a metal housing made of a rectangular frame and front and rear covers (see Fig. 1). The u.h.f. output connection is on the top of the housing, all other connections are made via feed-through capacitors on the underside. The mounting method is shown in Fig. 2.

MECHANICAL DATA

Dimensions in mm

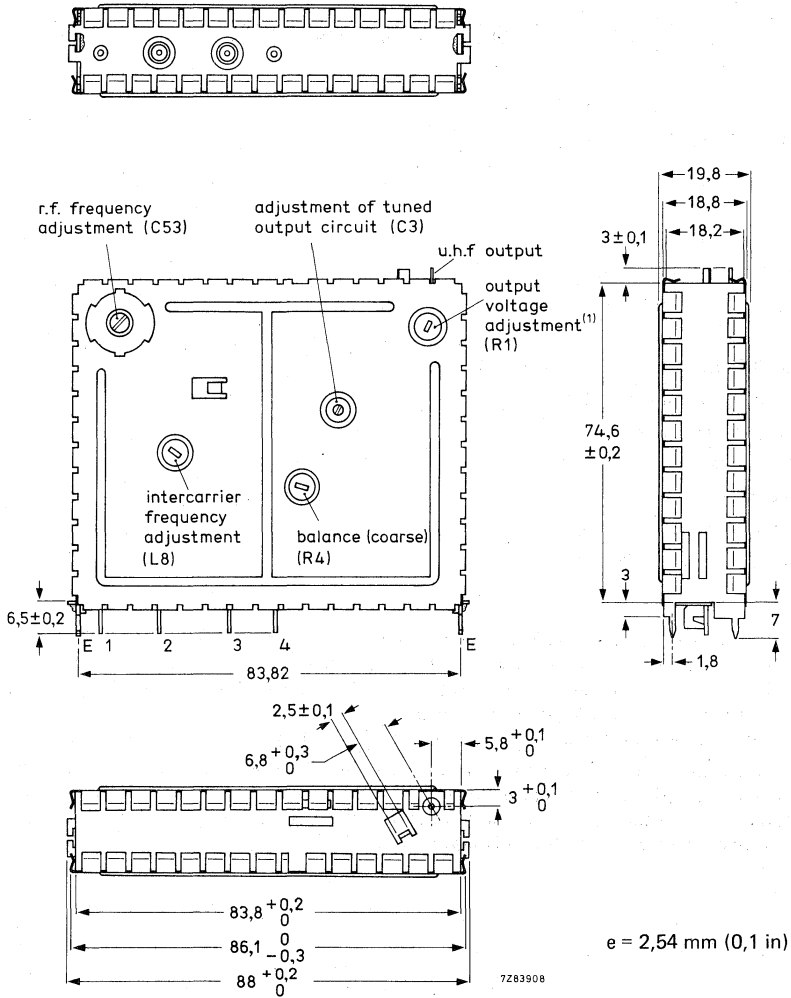

Fig. 1.

- Terminal 1 = sound input
- 2 = video reference input
- 3 = supply voltage, +12 V
- 4 = video input
- E = earth
- (1) only for REMO 101

Mounting

The modulators may be mounted by soldering on to a printed-wiring board, with connections shown by the piercing diagram in Fig. 2.

The solderability of the terminals and mounting tabs is according to IEC68-2, test Ta ($230 \pm 10 \text{ }^\circ\text{C}$, $2 \pm 0,5 \text{ s}$). The resistance to soldering heat is according to IEC68-2, test Tb ($260 \pm 5 \text{ }^\circ\text{C}$, $10 \pm 1 \text{ s}$).

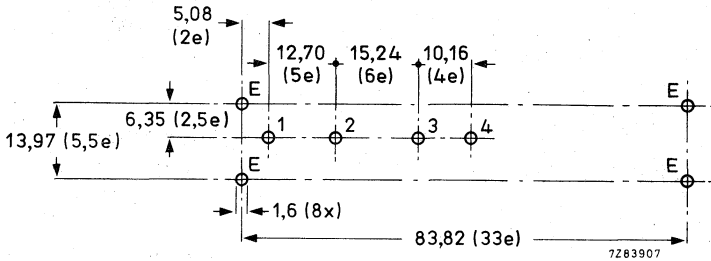

Fig. 2 Piercing diagram viewed from solder side of board; $e = 2,54 \text{ mm}$ ($0,1 \text{ in}$).



ELECTRICAL DATA

General

Semiconductors

r.f. oscillator	AF139
intercarrier oscillator	BF494
modulator	TDA0820

Ambient temperature range

operating	+ 5 to + 55 °C
storage	-20 to + 60 °C

Relative humidity

30 to 75%

Supply

Supply voltage

+ 12 ± 0,5 V

Current drawn from + 12 V supply

typ. 17 mA

Video modulation

Video input voltage (Fig. 3)

1 V(p-p)

Permissible voltage at video input

terminal (4), and at video reference
input terminal (2), for linear operation

max. 6 V
min. 2 V

**Input impedance at video input terminal (4)
and at video reference input terminal (2)**

> 50 kΩ

Residual carrier voltage*, except channels E30 and E40

≤ 2,5% of output voltage during
sync. pulse

channels E30 and E40

≤ 3,5% of output voltage during
sync. pulse

Differential gain

≤ 10%

Differential phase

≤ 15°

Sound modulation

Intercarrier sound frequency

REMO 101	5,5 MHz ± 3 kHz
----------	-----------------

REMO 201	6,0 MHz ± 3 kHz
----------	-----------------

Sound input voltage, for Δf = 25 kHz (f = 1 kHz)

1,0 V(r.m.s.)

Pre-emphasis

50 μs

Sound input impedance

> 30 kΩ

**Shift of oscillator frequency at a change of the
supply voltage from 11,5 to 12,5 V**

≤ 8 kHz

**Drift of oscillator frequency at a change of the
ambient temperature from 25 to 40 °C**

≤ 4 kHz

* When input voltages at terminals 2 and 4 are equal.

Output

Output voltage (picture carrier during sync. pulse)	4,0 to 7,3 mV(r.m.s.)*
Output voltage of each sound carrier (double-sideband modulation)	10 to 15 dB below picture carrier
Output impedance	75 Ω
Output frequency (picture carrier)	543,25 to 623,25 MHz (channels E30 to E40)
Output frequency shift at a change of the supply voltage from 11,5 to 12,5 V	≤ 100 kHz
Output frequency drift at a change of the ambient temperature from 25 to 40 °C	≤ 150 kHz
from 15 to 55 °C	≤ 420 kHz

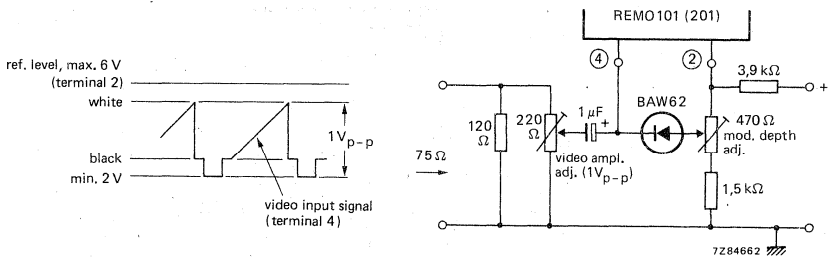

Fig. 3a Application diagram using a positive video signal.

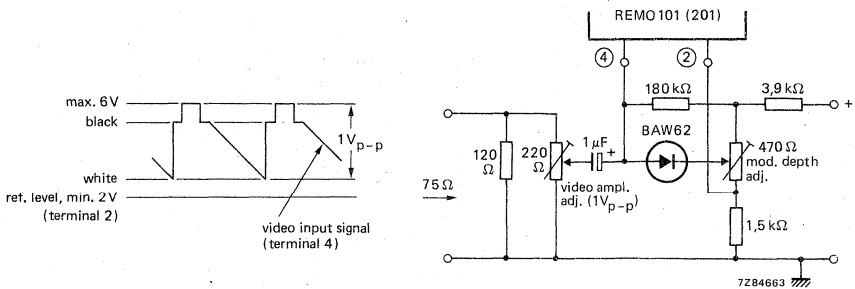

Fig. 3b Application diagram using a negative video signal.

Note: The r.f. output amplitude is proportional to the voltage difference between terminals 2 and 4.

* Adjustable for REMO 101.

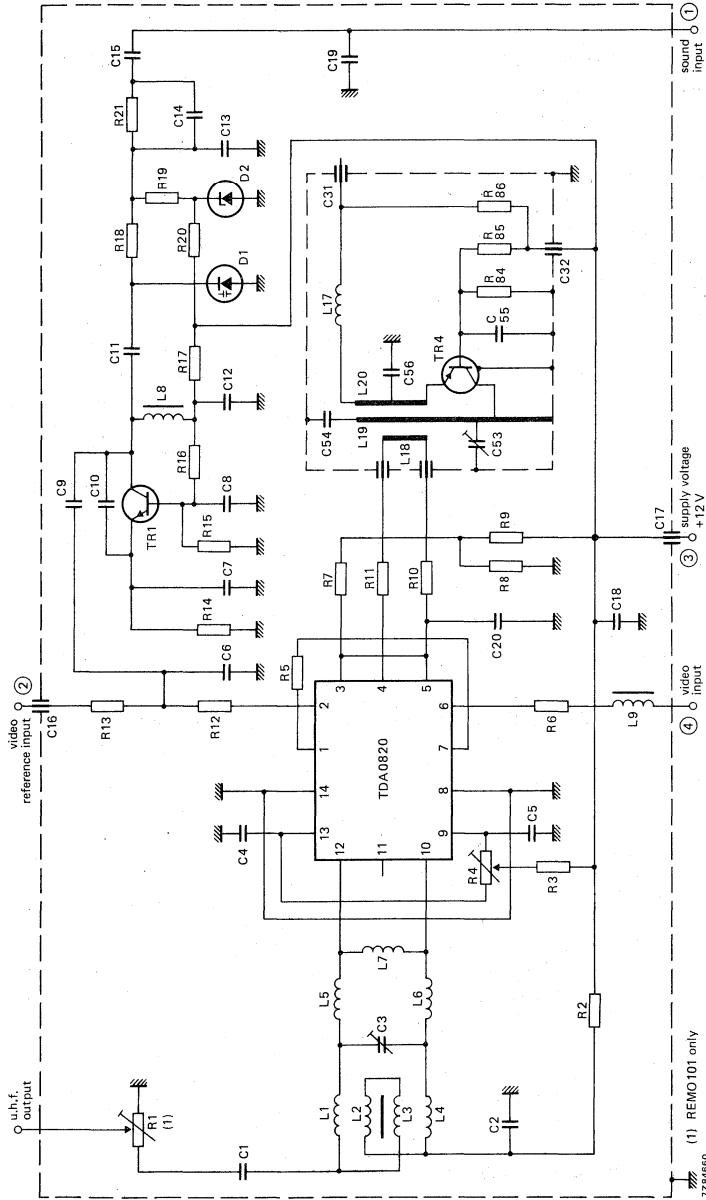

Fig. 4.

(1) REMO 101 only.



VIDEO MODULATOR

QUICK REFERENCE DATA

C.C.I.R. system	L
Channels	E30 to E40
Sound frequency	6,5 MHz

APPLICATION

These video modulators are for use in:

- video tape recorders (VCR);
- TV cameras;
- video games;
- video information systems;
- closed circuit TV video systems.

DESCRIPTION

In the video modulator, video and sound signals are modulated onto a u.h.f. carrier. The modulated carrier at the output is suited for connection to the aerial socket of normal television receivers. The carrier frequency can be adjusted from 540 to 624 MHz (channel E30 to channel E40) so 10 different channels can be linked via a single coaxial cable.

The modulator meets the radiation requirements of C.I.S.P.R. Recommendation No 13.

Mechanically, the modulators are built on a low-loss printed-wiring board, carrying all components, in a metal housing made of a rectangular frame and front and rear covers (see Fig. 1). The u.h.f. output connection is on the top of the housing, all other connections are made via feed-through capacitors in the underside. The mounting method is shown in Fig. 2.

MECHANICAL DATA

Dimensions in mm

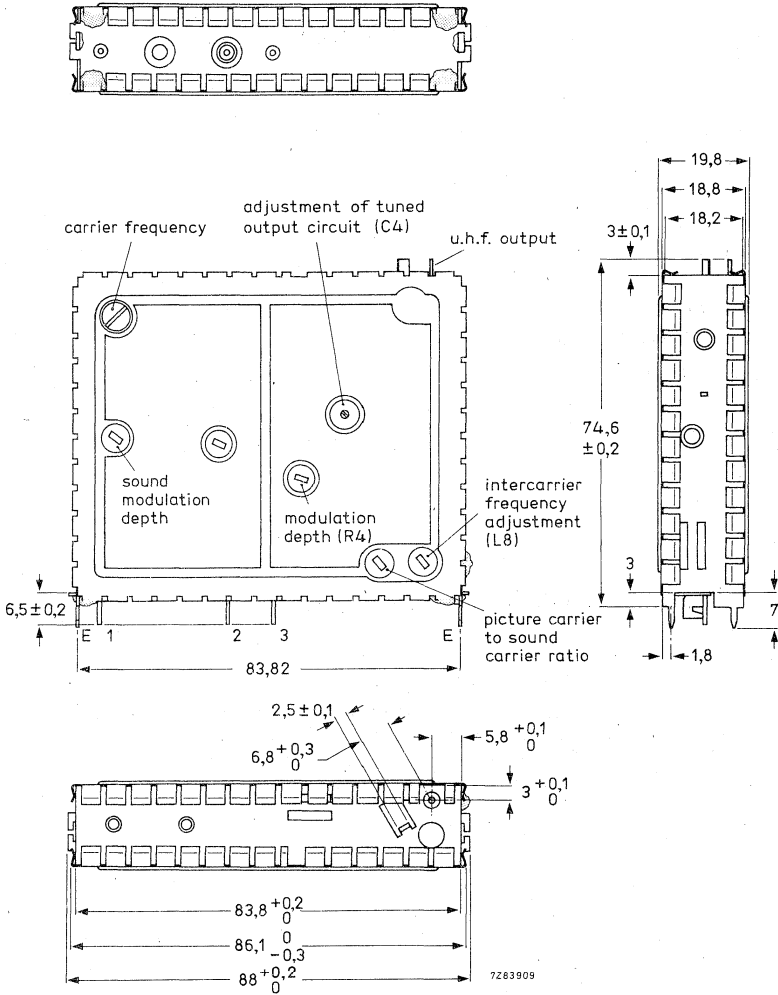

Fig. 1.

- Terminal 1 = sound input
- 2 = supply voltage, + 12 V
- 3 = video input
- E = earth

Mounting

The modulator may be mounted by soldering on to a printed-wiring board; with connections shown by the piercing diagram in Fig. 2.

The solderability of the terminals and mounting tabs is in accordance with IEC68-2, test Ta ($230 \pm 10 \text{ }^\circ\text{C}$; $2 \pm 0,5 \text{ s}$). The resistance to soldering heat is in accordance with IEC68-2, test Tb ($260 \pm 5 \text{ }^\circ\text{C}$, $10 \pm 1 \text{ s}$).

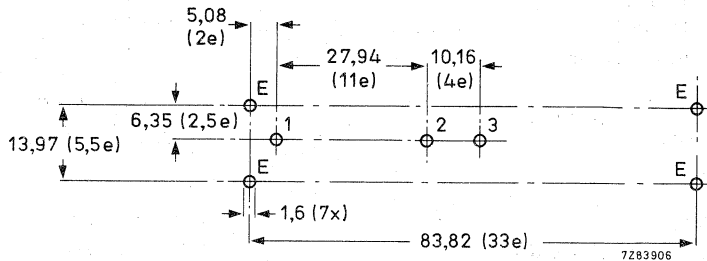

Fig. 2 Piercing diagram viewed from solder side of board; $e = 2,54 \text{ mm}$ (0,1 in).

ELECTRICAL DATA

All electrical values are specified at an ambient temperature of 25 °C and a supply voltage of 12 V.

General**Semiconductors and integrated circuits**

sound amplifier	BC547A
sound modulator	TCA240
r.f. oscillator	BF569
picture modulator	TDA0820T
video emitter follower	BC548

Ambient temperature range

operating	+ 5 to + 55 °C
storage	-20 to + 70 °C

Relative humidity

30 to 75%

Supply

Supply voltage	+ 12 ± 0,5 V
Current drawn from + 12 V supply	typ. 50 mA

Video modulation

Video input voltage	1 V (p-p)
D.C. level of sync.	2 to 4 V
Input impedance at video input	min. 50 kΩ
Modulation depth	87 to min. 95%
Residual carrier voltage	max. 5% of output voltage during white
Difference gain	max. 10%
Differential phase	max. 15°

Sound modulation

Sound frequency	6,5 MHz ± 10 kHz
Sound input voltage at 40% amplitude modulation	1,0 V r.m.s.
Sound input impedance	min. 5 kΩ
Bandwidth (-1 dB)	50 Hz to 15 kHz
Shift of oscillator frequency for a change of supply voltage from 11,5 to 12,5 V	max. 10 kHz
Drift of oscillator frequency over ambient temperature range 25 to 40 °C	max. 8 kHz

Output

Output voltage (picture carrier during white level)	min. 4,0 mV (r.m.s.)
Output voltage of each sound carrier (double-sideband modulation)	11 to 16 dB below picture carrier during white level
Output impedance	75 Ω
Output frequency	543,25 to 623,25 MHz (channels E30 to E40)
Output frequency shift for a change of supply voltage from 11,5 to 12,5 V	max. 100 kHz
Output frequency drift over ambient temperature range 25 to 40 °C	max. 150 kHz
range 15 to 55 °C	max. 420 kHz



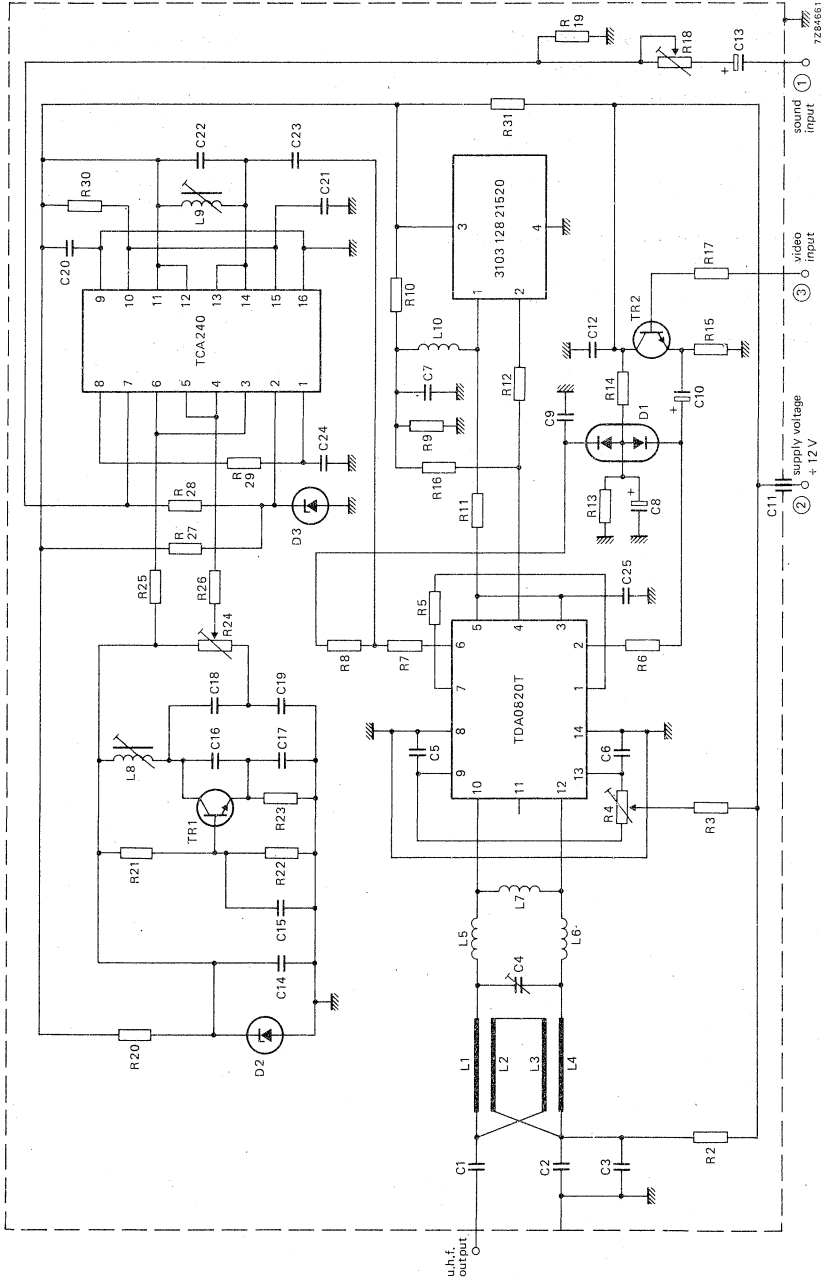

Fig. 3.

SURFACE ACOUSTIC WAVE FILTERS



SURFACE ACOUSTIC WAVE FILTER

The RW153A is a lithium niobate surface wave device for use as an i.f. bandpass filter in colour and monochrome TV receivers. Its low input capacitance improves the signal handling capabilities of the driving pre-amplifier. It is specifically designed for CCIR system I as used in the United Kingdom. Its use in place of conventional LC circuitry improves the amplitude and group delay characteristics, as well as avoiding the necessity for critical adjustments during receiver production. The response characteristics are stable with life.

QUICK REFERENCE DATA

	Frequency MHz		Amplitude dB
Vision carrier	39,5		-6
Sound carrier	33,5	typ.	-19
Adjacent vision trap	31,5	<	-40
Adjacent sound trap	41,5	typ.	-46
Insertion loss (300 Ω source and load)	37,0	typ.	16
Operating temperature range	-10 to +70 $^{\circ}$ C		

MECHANICAL DATA

Dimensions in mm

5 lead TO-8

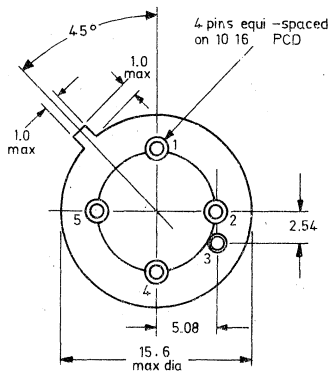
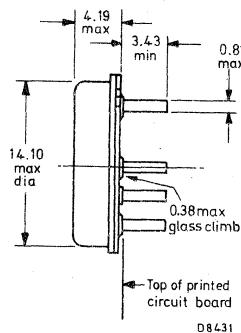

Fig. 1a Connections:

1. balanced output
2. input high
3. can (earth)
4. input (earth)
5. balanced output

Fig. 1b Printed circuit board
hole layout
Standard 0,1" grid
Hole dia. 1,2 mm min.

RATINGS

Limiting values in accordance with the Absolute Maximum System (IEC134)

Operating ambient temperature	-10 to +70	°C
Storage temperature	-25 to +85	°C
Pin to pin voltage (short term) max.*	30	V

CHARACTERISTICS**Test conditions****

Ambient temperature	25	°C
Input drive impedance	50	Ω
Load impedance (balanced)	300	Ω

Amplitude response

	Frequency MHz	Amplitude dB		
		min.	typ.	max.
Vision carrier (reference level)	39,5		-6	
Chroma carrier	35,07	-3	-1	
Sound carrier	33,5	-21	-19	-18
Adjacent vision trap	31,5			-40
Adjacent sound trap	41,5		-46	
In-band ripple (p-p)	36 to 38		0,5	1,0
Out of band response	0 to 60			-38
Out of band response	60 to 100			-15

* For maximum operating life, the filter should be used with d.c. isolating capacitors.

**The amplitude level at the vision carrier frequency is -6 dB and is used as the reference for all relevant measurements.

General

	Frequency MHz		
Insertion loss (300 Ω source and load)	36 to 38	typ.	16 dB
Voltage attenuation ratio (in preferred application circuit with a 50 Ω source and 300 Ω load)	37	typ.	18 dB
Group delay (relative to 0 ns at 39,5 MHz)	34,5 to 40,5	min.	-40 ns
		max.	+40 ns
Spurious reflections and direct breakthrough (measured using 2Tsin ² pulse and bar)	39,5	max.	-40 dB
2Tsin ² pulse and bar k rating		max.	3,0 %
Temperature coefficient of frequency		typ.	-60 x10 ⁻⁶ /K
Small-signal impedance			
input	37,0	typ.	1,4 kΩ//8,5 pF
output	37,0	typ.	1,5 kΩ//14 pF

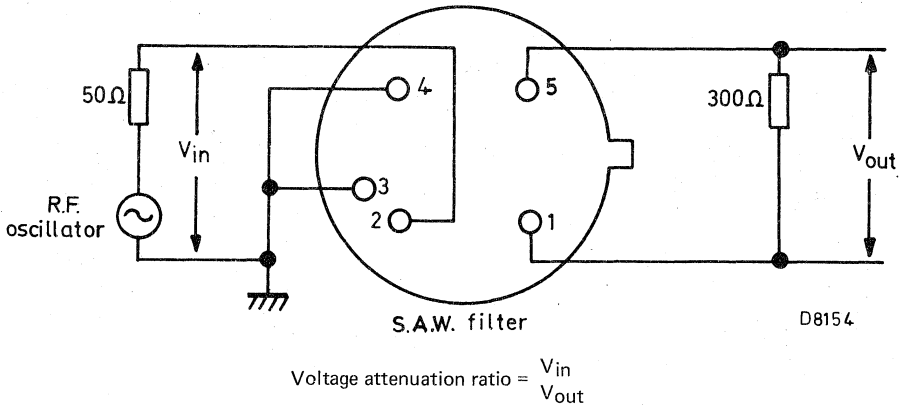

Fig. 2 Test and basic application circuit.

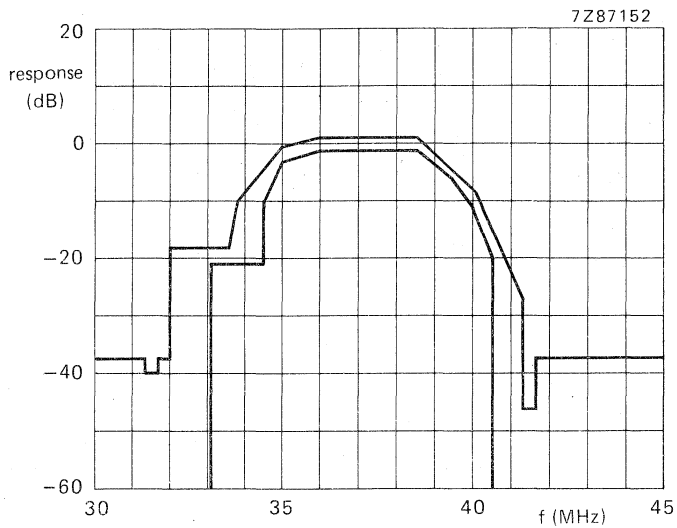
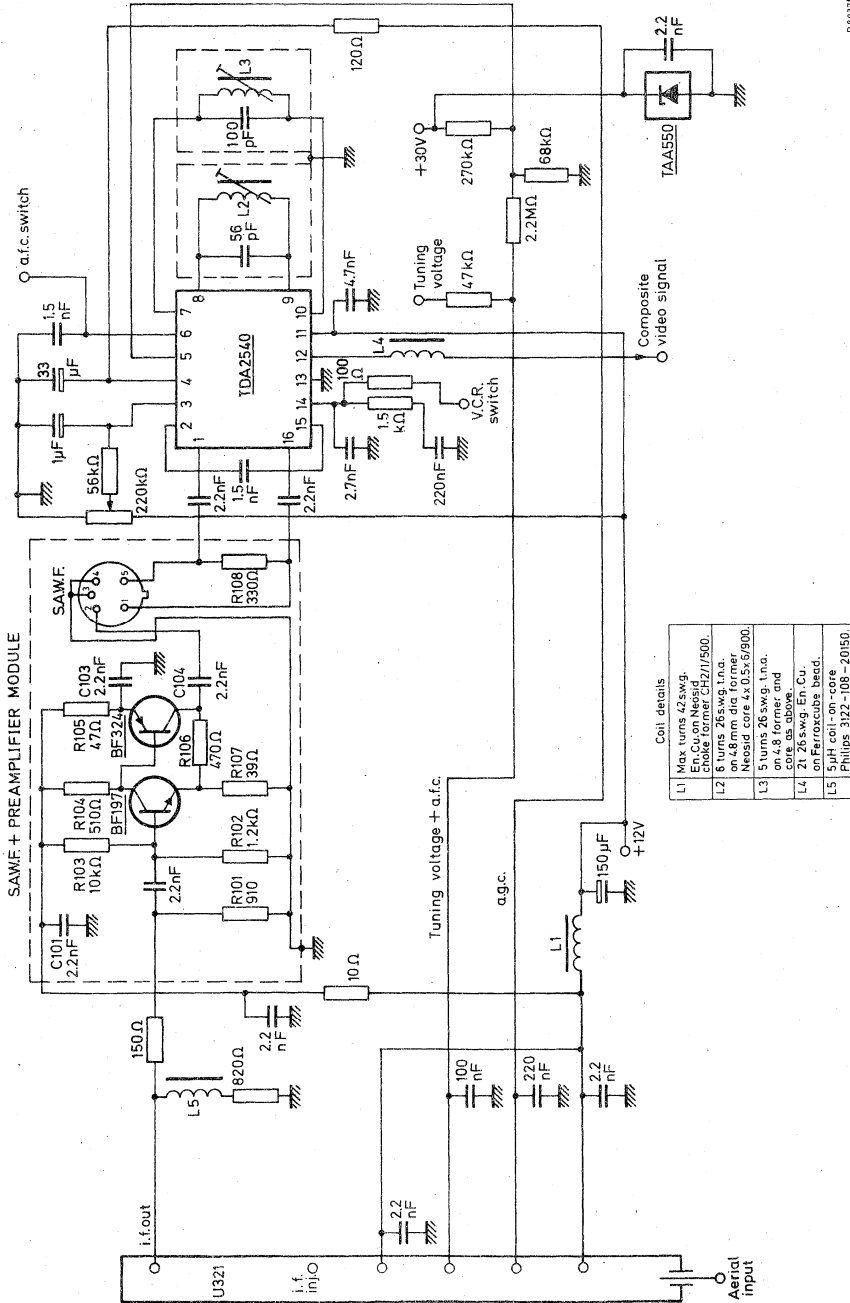

Fig. 3.

080376



Coil details

L1	Max turns 425wg. En. Cu on Neosid. Core Ferric Oxide on 48mm dia former
L2	5 turns 26 swg. En. Cu on Neosid. Core Ferric Oxide on 48mm dia former
L3	5 turns 26 swg. t.n.a. core as above.
L4	27 26 swg. En. Cu. on Ferronacids bead.
L5	5 turns 26 swg. En. Cu. on Ferronacids bead. Philips: 3122-108-20150.

Fig. 4.

SURFACE ACOUSTIC WAVE FILTER

The RW154 is a lithium niobate surface wave device for use as an i.f. bandpass filter in colour and monochrome TV receivers. It is specifically designed for CCIR system I as used in the United Kingdom. Its use in place of conventional LC circuitry improves the amplitude and group delay characteristics, as well as avoiding the necessity for critical adjustments during receiver production. The response characteristics are stable with life.

QUICK REFERENCE DATA

	Frequency MHz		Amplitude dB
Vision carrier	39,5		-6
Sound carrier	33,5	typ.	-20
Adjacent vision trap	31,5	<	-40
Adjacent sound trap	41,5	<	-46
Insertion loss (300 Ω source and load)	37,0	typ.	20
Operating temperature range	-10 to +70 °C		

MECHANICAL DATA

Dimensions in mm

5 lead TO-8

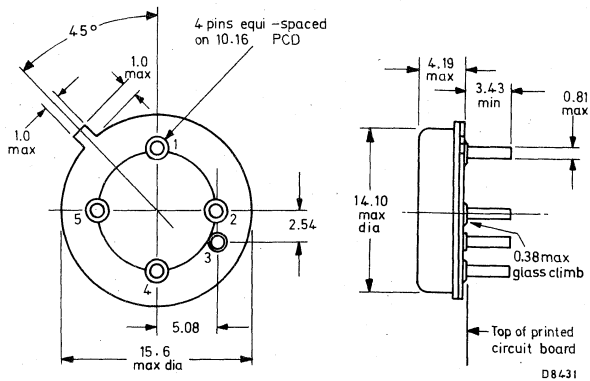

Fig. 1a Connections:

1. balanced output
2. input high
3. can (earth)
4. input (earth)
5. balanced output

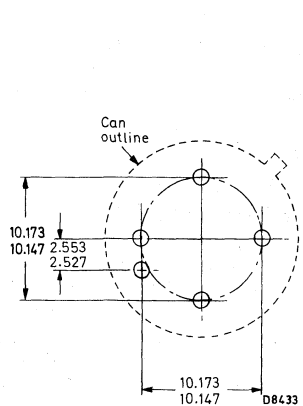

Fig. 1b Printed circuit board

hole layout
Standard 0,1" grid
Hole dia. 1,2 mm min.

RATINGS

Limiting values in accordance with the Absolute Maximum System (IEC 134)

Operating ambient temperature	-10 to +70 °C
Storage temperature	-25 to +85 °C
Pin to pin voltage (short term) max.*	30 V

CHARACTERISTICS

Test conditions**

Ambient temperature	25 °C
Input drive impedance	50 Ω
Load impedance (balanced)	300 Ω

Amplitude response	Frequency MHz	Amplitude dB		
		min.	typ.	max.
Vision carrier (reference level)	39,5		-6	
Chroma carrier	35,07	-3	-2	0
Sound carrier	33,5	-22	-20	-18
Adjacent vision trap	31,5			-40
Adjacent sound trap	41,5		-50	-46
In-band ripple (p-p)	36 to 38		0,5	1,0
Out of band response	10 to 80			-38
Out of band response	60 to 100			-20

General

	Frequency MHz		
		typ.	
Insertion loss (300 Ω source and load)	36 to 38	typ.	20 dB
Voltage attenuation ratio (in preferred application circuit with a 50 Ω source and 300 Ω load)	37	typ.	24 dB
Group delay (relative to 0 ns at 39,5 MHz)	34,5 to 40,5	min.	-40 ns
		max.	+40 ns
Spurious reflections and direct breakthrough (measured using 2Tsin ² pulse and bar)	39,5	max.	-40 dB
2Tsin ² pulse and bar k rating		max.	3,0 %
Temperature coefficient of frequency		typ.	-90 ×10 ⁻⁶ /K
Small-signal impedance	37,0	typ.	2,3 kΩ//12 pF
		output	typ. 2,2 kΩ//6,0 pF

* For maximum operating life, the filter should be used with d.c. isolating capacitors.

** The amplitude level at the vision carrier frequency is -6 dB and is used as the reference for all relevant measurements.

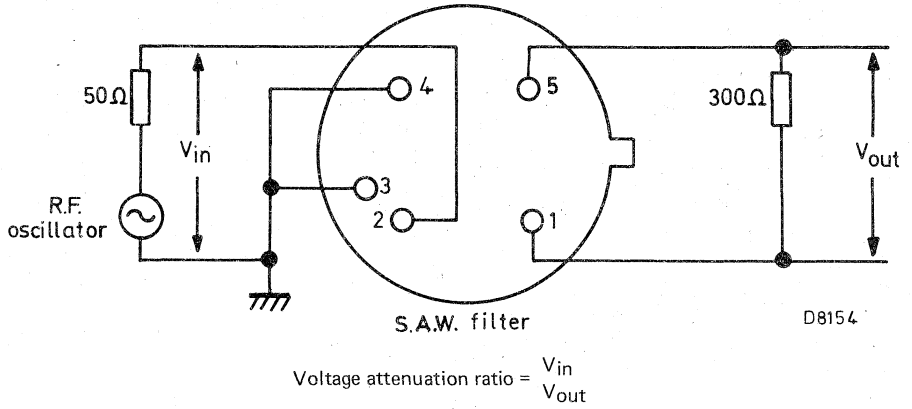

Fig. 2 Test and basic application circuit.

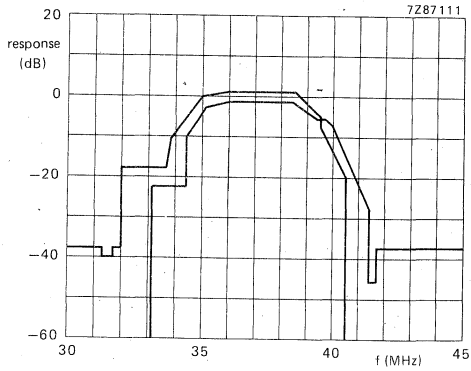
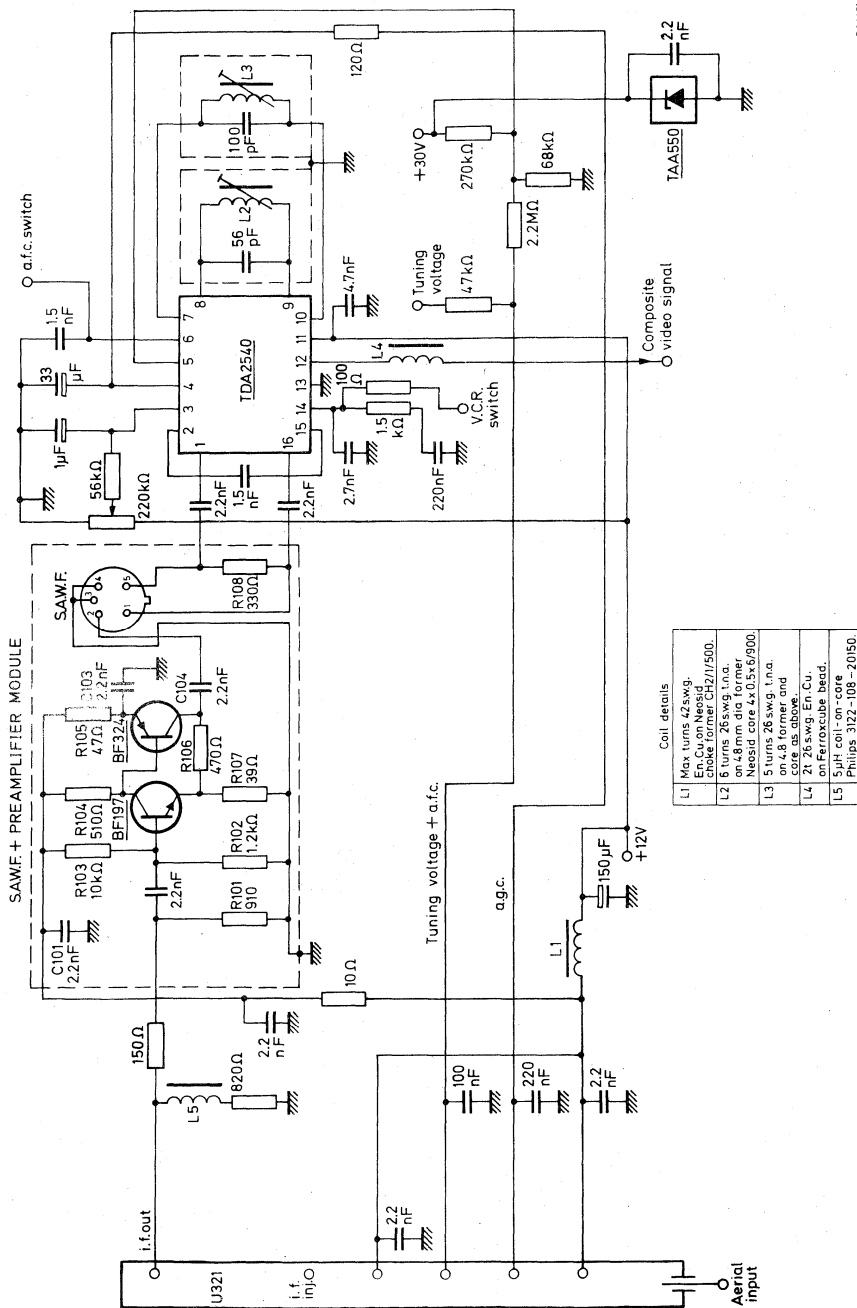

Fig. 3 Tolerance graticule, system I.



Coil details

L1	Max. turns 425.w.g. En.Cu. on Neesid choke former CHZ1/1500.
L2	6 turns 265.w.g. t.n.a. on 4.8mm dia former. Neesid core 4x0.5x0.9/900.
L3	5 turns 265.w.g. t.n.a. on 4.8mm dia former. Neesid core 4x0.5x0.9/900.
L4	21 265.w.g. En.Cu. on Ferroxcube bead.
L5	5µH coil-on-core Philips 3122-108-20150.

Fig. 4.

D4037b

SURFACE ACOUSTIC WAVE FILTER

The RW171 is a lithium niobate surface wave device for use as an i.f. bandpass filter in colour and monochrome TV receivers. It is specifically designed for CCIR systems B and G as used in European and other countries. This device has an improved sound shelf specification over the SW211/M. Its use in place of conventional LC circuitry improves the amplitude and group delay characteristics as well as avoiding the need for critical adjustments in receiver production. The response characteristics are stable with life.

QUICK REFERENCE DATA

	Frequency MHz		Amplitude dB
Vision carrier	38.9		-6
Sound carrier	33.4	typ.	-18.5
Adjacent vision trap	31.9	<	-40
Adjacent sound trap	40.4	<	-46
	41.4	<	-40
Insertion loss (300 Ω source and load)	37.0	typ.	20
Operating temperature range	-10 to +70 °C		

MECHANICAL DATA

Dimensions in mm

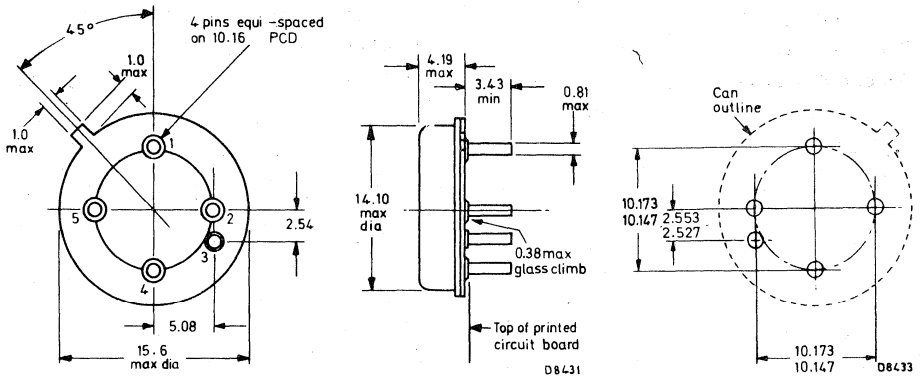

- Connections
1. balanced output
 2. input high
 3. can earth
 4. input earth
 5. balanced output

Printed circuit board hole layout
Standard 0.1" grid
Hole dia. 1.2 mm min.

RATINGS

Limiting values in accordance with the Absolute Maximum System (IEC134)

Operating ambient temperature	-10 to +70	°C
Storage temperature	-25 to +85	°C
Pin to pin voltage (short term) max. note 1	30	V

CHARACTERISTICS

Test conditions note 2

Ambient temperature	25	°C
Input drive impedance	50	Ω
Load impedance (balanced)	300	Ω

Amplitude response

	Frequency MHz	Amplitude dB		
		min.	typ.	max.
Vision carrier (reference level)	38.9		-6	
Chroma carrier	34.47	-6	-4	-2
Sound carrier	33.4	-21	-18.5	-16
Adjacent vision trap	31.9			-40
Adjacent sound trap				
system B	note 3	40.4	-50	-46
system G	note 4	41.4	-45	-40
In-band ripple (p-p)	36 to 38		0.5	1.0
Out of band response	10 to 60			-38
Out of band response	60 to 100			-20

Notes

1. For maximum operating life, the filter should be used with d.c. isolating capacitors.
2. The amplitude level at the vision carrier frequency is -6 dB and is used as the reference for all relevant measurements.
3. 7 MHz channel spacing.
4. 8 MHz channel spacing.

General

	Frequency MHz		
Insertion loss (300 Ω source and load)	36 to 38	typ.	20 dB
Voltage attenuation ratio (in preferred application circuit with 50 Ω source and 300 Ω load)	37	typ.	23 dB
Group delay (relative to 0 ns at 38.9 MHz)	34.1 to 39.65	see fig. 2	
Spurious reflections and direct breakthrough (measured using 2T sin ² pulse and bar)	38.9	max.	-40 dB
2Tsin ² pulse and bar k rating			3.0 %
Temperature coefficient of frequency		typ.	-90 ×10 ⁻⁶ /K
Small signal impedance			
input	37.0		1.2 kΩ//22 pF
output	37.0		1.2 kΩ//8.5 pF

Test and basic application circuit

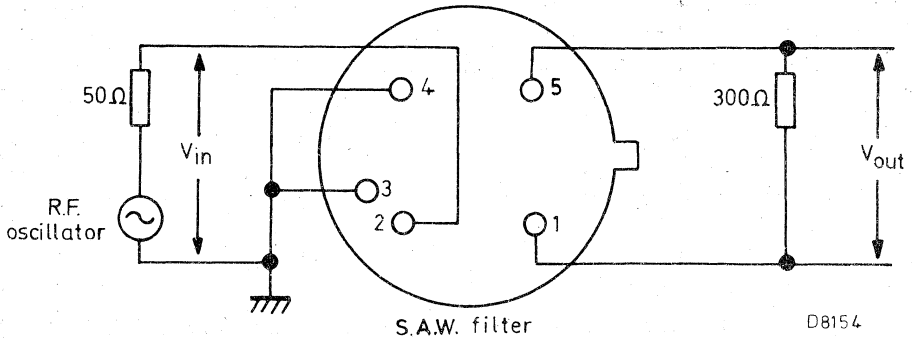

$$\text{Voltage attenuation ratio} = \frac{V_{in}}{V_{out}}$$

Fig.1

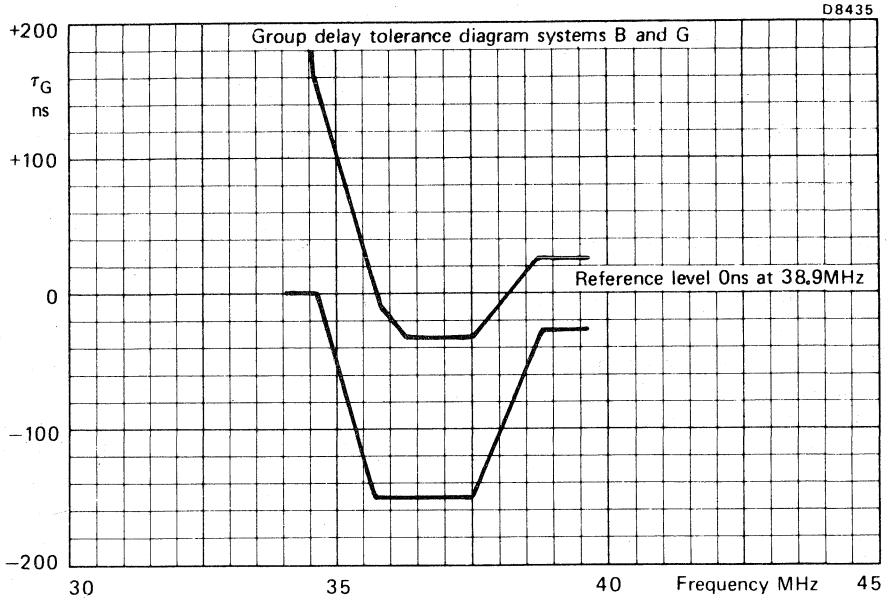

Fig. 2

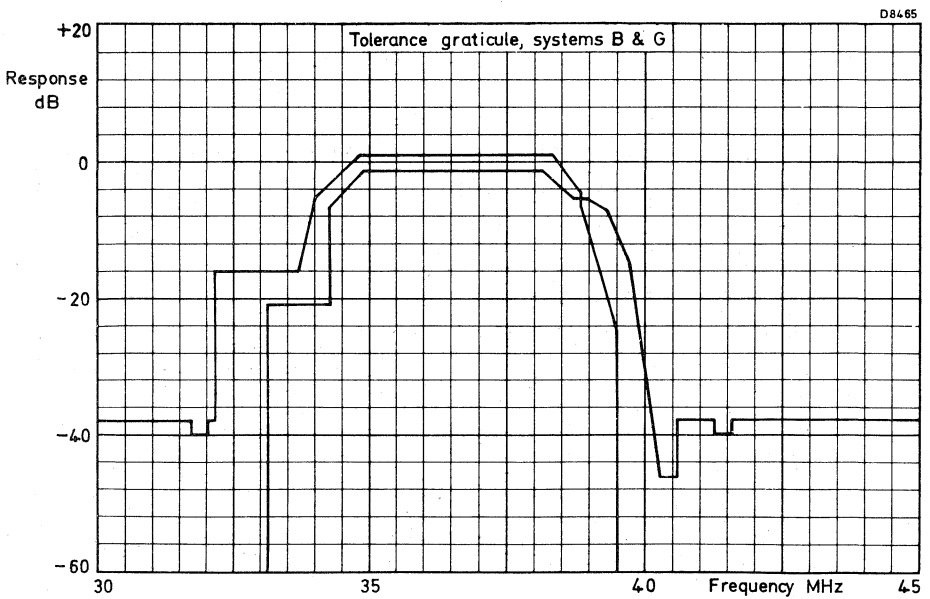

Fig. 3

DP 166

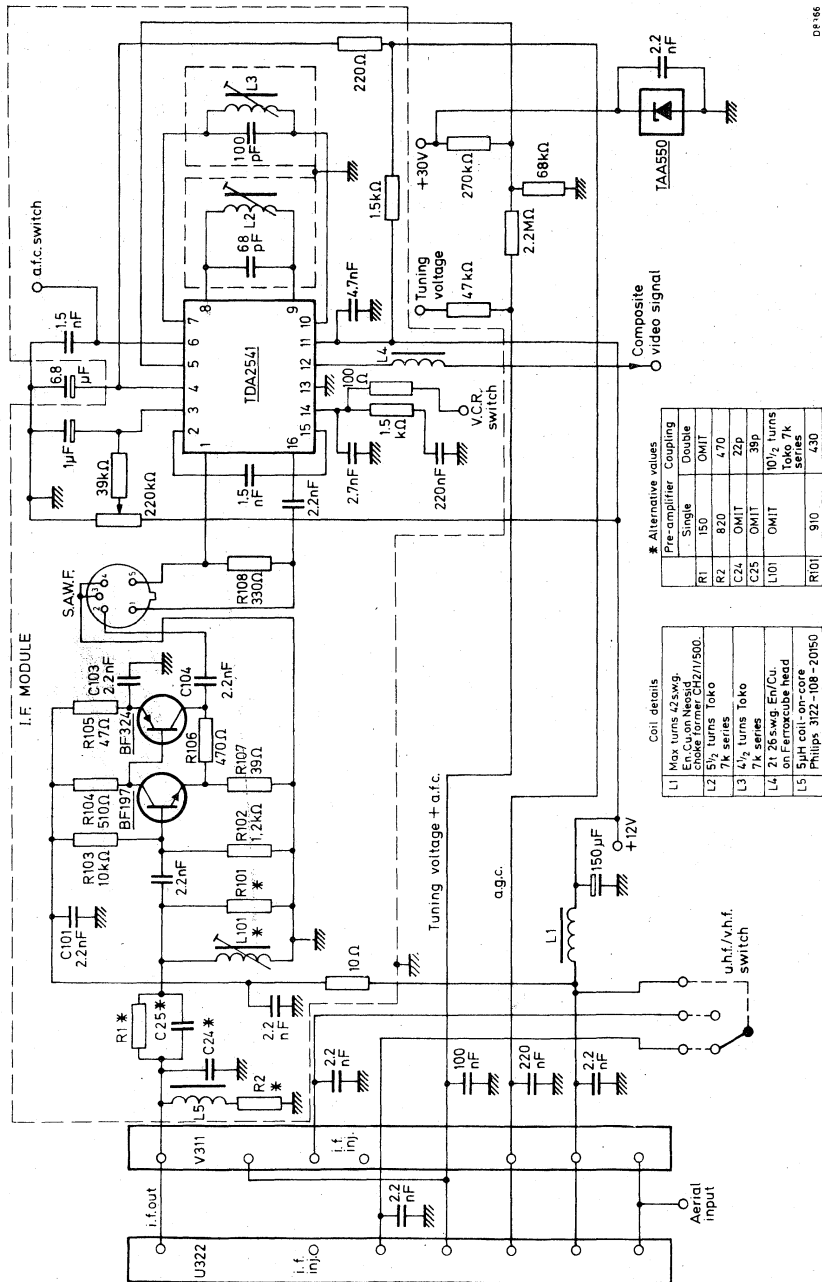

Fig. 4

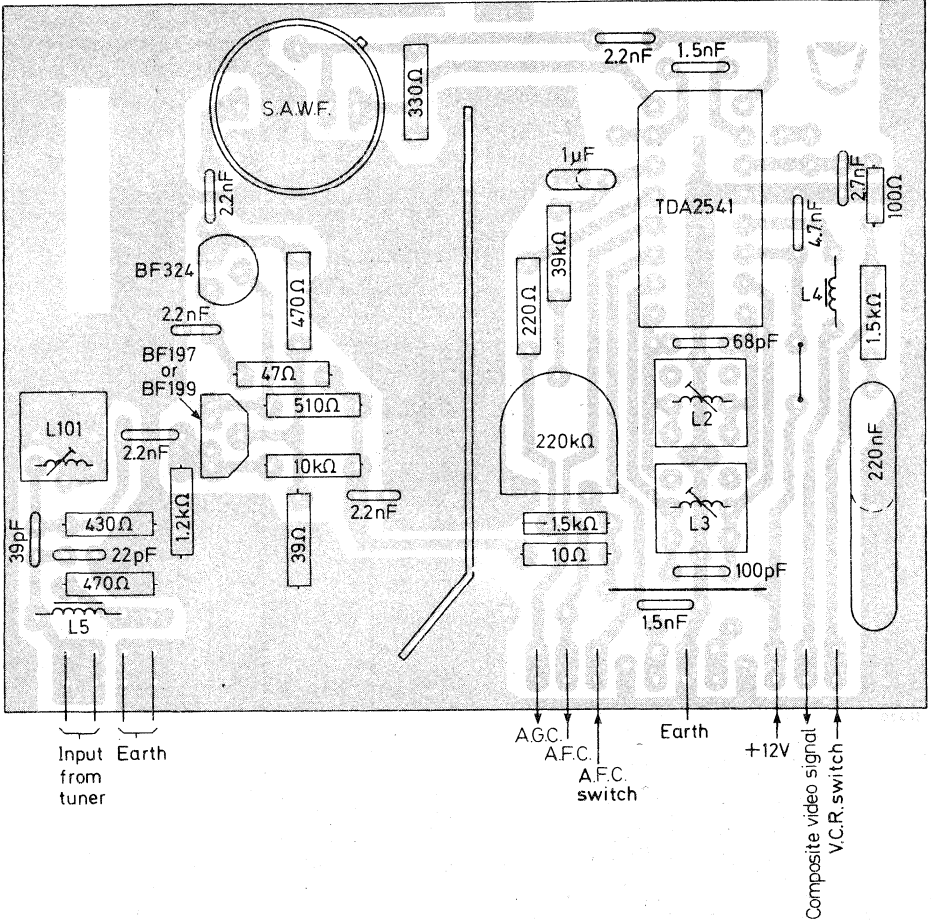

Fig. 5 Recommended printed circuit board layout for surface acoustic wave filter and pre-amplifier

DEVELOPMENT SAMPLE DATA

This information is derived from development samples made available for evaluation. It does not necessarily imply that the device will go into regular production.

RW173

SURFACE ACOUSTIC WAVE FILTER

The RW173 is a lithium niobate surface wave device for use as an i.f. bandpass filter in colour and monochrome TV receivers. It is specifically designed for CCIR systems B and G as used in European and other countries. This device has an improved sound shelf specification over the SW211/M. Its use in place of conventional LC circuitry improves the amplitude and group delay characteristics as well as avoiding the need for critical adjustments in receiver production. The response characteristics are stable with life.

QUICK REFERENCE DATA

	Frequency MHz		Amplitude dB
Vision carrier	38.9		-6
Sound carrier	33.4	typ.	-18.5
Adjacent vision trap	31.9	<	-40
Adjacent sound trap	system B	<	-46
	system G	<	-40
Insertion loss (300 Ω source and load)	37.0	typ.	16
Operating temperature range	-10 to +70 °C		

MECHANICAL DATA

Dimensions in mm

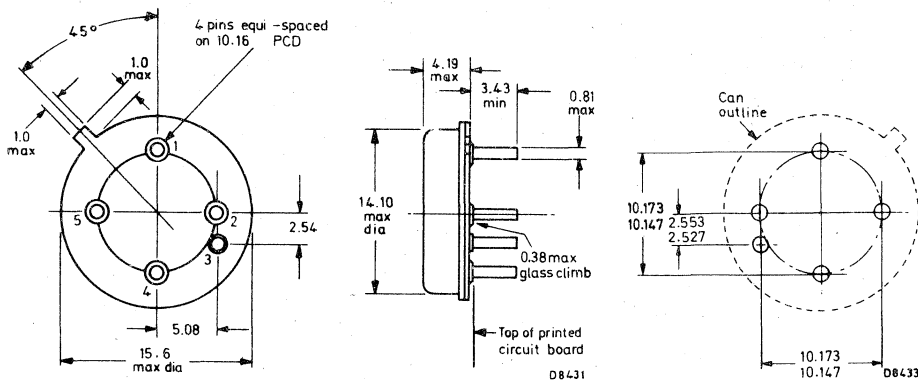

- Connections
- 1. balanced output
 - 2. input high
 - 3. can earth
 - 4. input earth
 - 5. balanced output

Printed circuit board hole layout
Standard 0.1" grid
Hole dia. 1.2 mm min.

RATINGS

Limiting values in accordance with the Absolute Maximum System (IEC134)

Operating ambient temperature	-10 to +70	°C
Storage temperature	-25 to +85	°C
Pin to pin voltage (short term) max. note 1	30	V

CHARACTERISTICS

Test conditions note 2

Ambient temperature	25	°C
Input drive impedance	50	Ω
Load impedance (balanced)	300	Ω

Amplitude response

		Frequency MHz	Amplitude dB		
Vision carrier (reference level)		38.9	-6		
			min.	typ.	max.
Chroma carrier		34.47	-6	-4	-2
Sound carrier		33.4	-21	-18.5	-16
Adjacent vision trap		31.9			-40
Adjacent sound trap	system B	40.4		-50	-46
	system G	41.4		-45	-40
In-band ripple (p-p)		36 to 38	0.5		1.0
Out of band response		10 to 60			-38
Out of band response		60 to 100			-20

Notes

1. For maximum operating life, the filter should be used with d.c. isolating capacitors.
2. The amplitude level at the vision carrier frequency is -6 dB and is used as the reference for all relevant measurements.
3. 7 MHz channel spacing.
4. 8 MHz channel spacing.

General

	Frequency MHz		
Insertion loss (300 Ω source and load)	36 to 38	typ.	16 dB
Voltage attenuation ratio (in preferred application circuit with 50 Ω source and 300 Ω load)	37	typ.	23 dB
Group delay (relative to 0 ns at 38.9 MHz)	34.1 to 39.65	see fig. 2	
Spurious reflections and direct breakthrough (measured using 2T sin ² pulse and bar)	38.9	max.	-40 dB
2Tsin ² pulse and bar k rating			3.0 %
Temperature coefficient of frequency		typ.	-90 × 10 ⁻⁶ /K
Small signal impedance			
input	37.0		3 kΩ//6.5 pF
output	37.0		1.1 kΩ//15 pF

DEVELOPMENT SAMPLE DATA

Test and basic application circuit

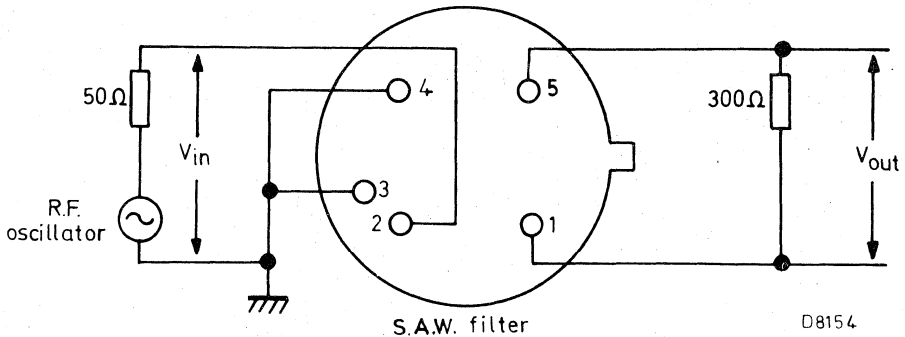

$$\text{Voltage attenuation ratio} = \frac{V_{in}}{V_{out}}$$

Fig.1

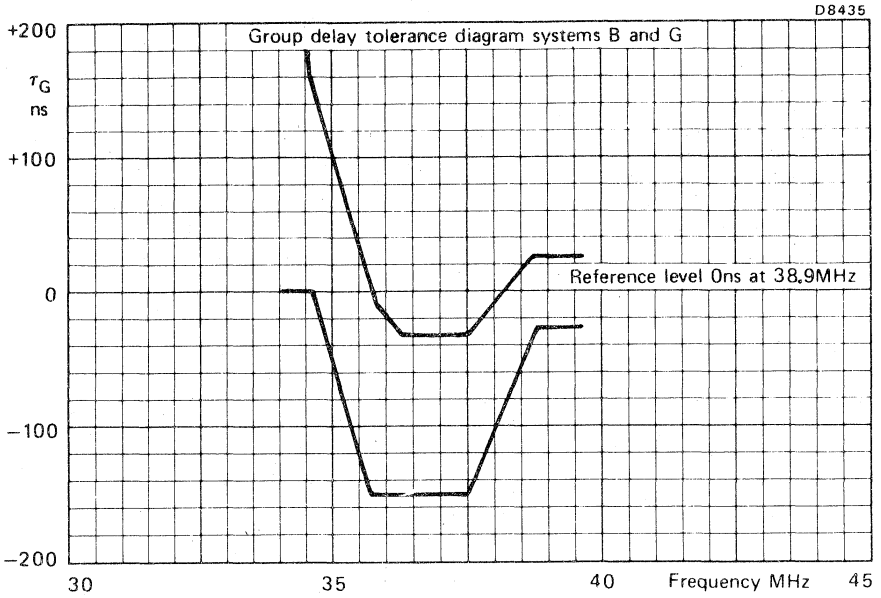

Fig. 2

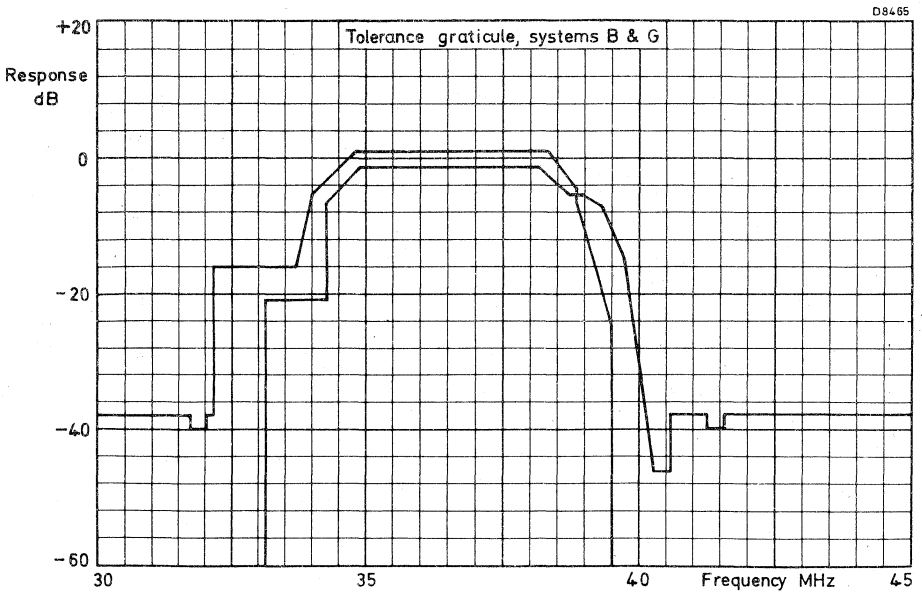
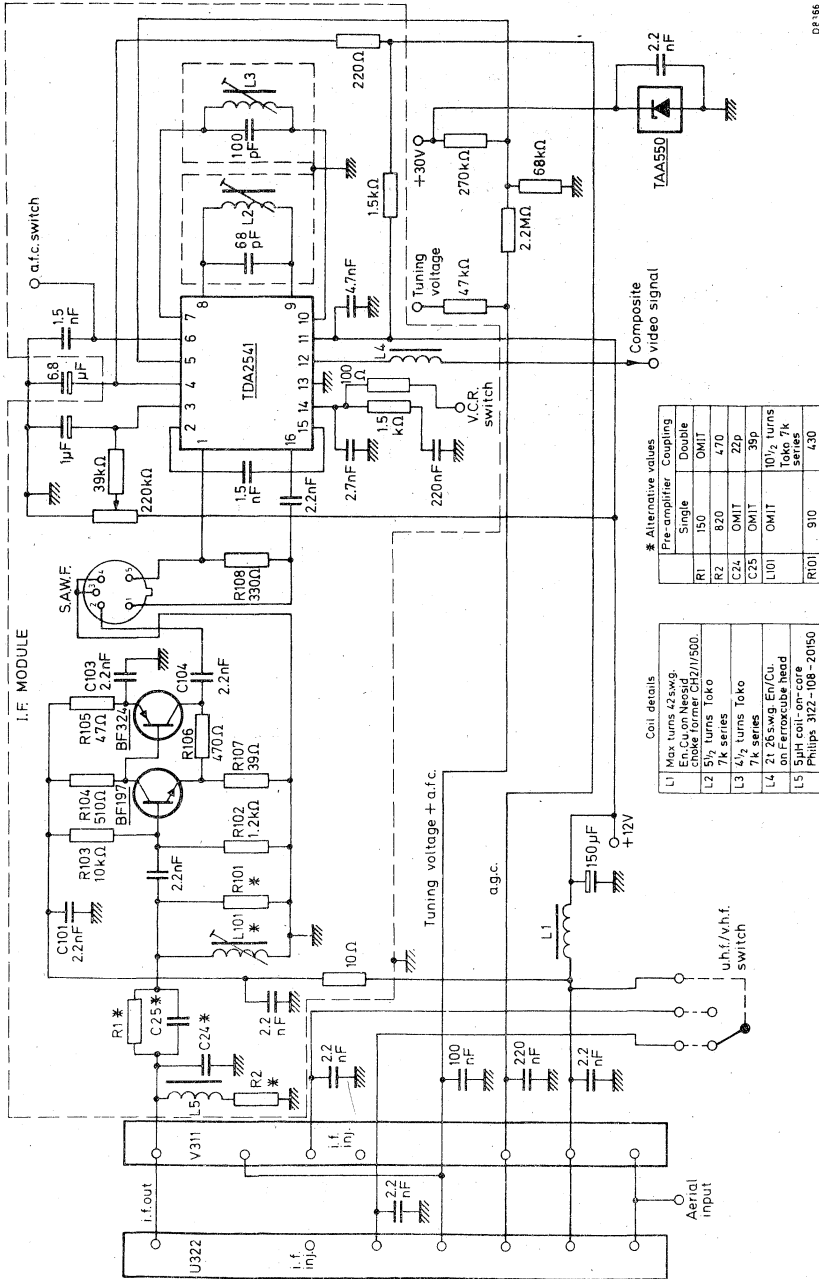

Fig. 3

DEVELOPMENT SAMPLE DATA



* Alternative values

	Pre-amplifier	Coupling
R1	150	Double
R2	820	OMIT
C24	OMIT	22p
C25	OMIT	39p
L101	OMIT	10 1/2 turns Toko 7k series
R101	910	430

Coil details

L1	Max. turns 425wg. on Ferracube head on Philips 3122-108-20150
L2	5 1/2 turns Toko 7k series
L3	4 1/2 turns Toko 7k series
L4	21 265wg. Enr/Cu. on Ferracube head
L5	Split coil-on-core series Philips 3122-108-20150

Fig. 4

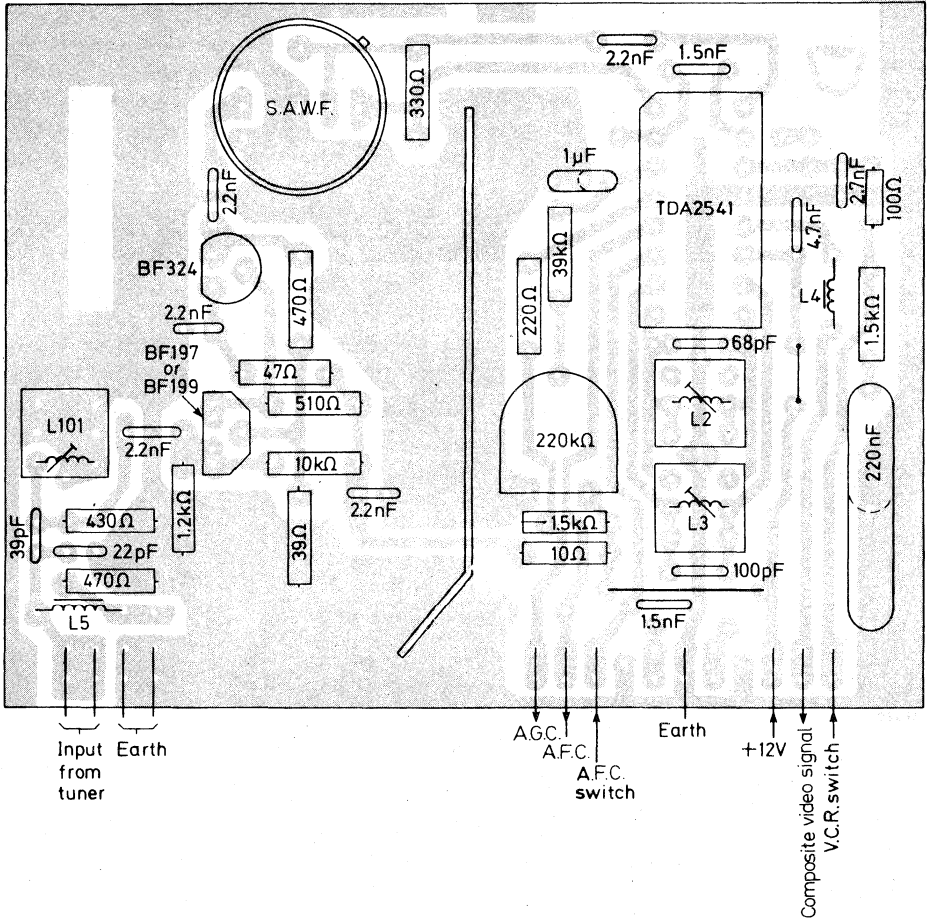

Fig. 5 Recommended printed circuit board layout for surface acoustic wave filter and pre-amplifier

SURFACE ACOUSTIC WAVE FILTER

The RW300 is a lithium niobate surface wave device for use as an i.f. bandpass filter in colour and monochrome TV receivers. It has been designed to give optimum performance for the French transmission systems L and L'. Its use in place of conventional LC circuitry improves the amplitude and group delay characteristics as well as avoiding the need for critical adjustments in receiver production. The response characteristics are stable with life.

QUICK REFERENCE DATA

	Frequency MHz		Amplitude dB
Vision carrier	32,7		-6
Adjacent vision trap	40,7	<	-35
Sound trap			
v.h.f.	43,85	<	-40
u.h.f.	39,2	<	-40
Adjacent sound trap	31,2	<	-40
Insertion loss (300 Ω source and load)	36,0	typ.	23
Operating temperature range	-10 to + 70 °C		

MECHANICAL DATA

Dimensions in mm

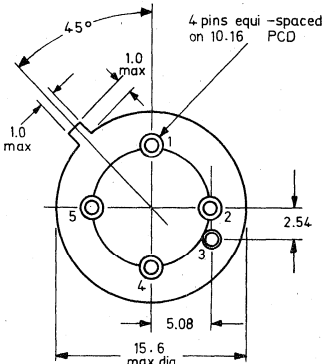

Fig. 1a Connections:

1. balanced output
2. input high
3. can earth
4. input earth
5. balanced output

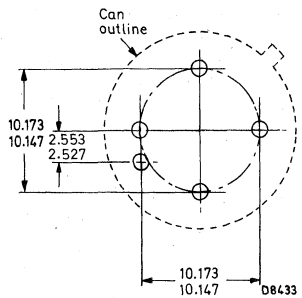
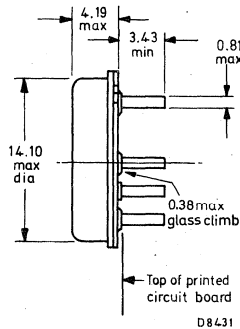

Fig. 1b

Printed circuit board hole layout
Standard 0,1" grid
Hole dia. 1,2 mm min.

RATINGS

Limiting values in accordance with the Absolute Maximum System (IEC 134)

Operating ambient temperature	-10 to + 70 °C
Storage temperature	-25 to + 85 °C
Pin to pin voltage (short term) max.*	30 V

CHARACTERISTICS

Test conditions**

Ambient temperature	25 °C
Input drive impedance	50 Ω
Load impedance (balanced)	300 Ω

Amplitude response

	Frequency MHz	Amplitude dB		
		min.	typ.	max.
Vision carrier (reference level)	32,7	-6		
Chroma carrier fR	36,95	-1,5		+ 1,5
Chroma carrier fB1	37,10	-1,5		+ 1,5
Upper chroma limit	38,0	-6		
Adjacent vision trap	40,7			-35
Sound trap				
v.h.f.	43,85			-40
u.h.f.	39,2			-40
Adjacent sound trap	31,2			-40
In-band ripple (p-p)	35 to 37		0,5	1,0
Out of band response			see Fig. 3	

* For maximum operating life, the filter should be used with d.c. isolating capacitors.

** The amplitude level at the vision carrier frequency is -6 dB and is used as the reference for all relevant measurements.

General

	Frequency MHz		
Insertion loss (300 Ω source and load)	36	typ.	23 dB
Voltage attenuation ratio (in preferred application circuit with 50 Ω source and 300 Ω load)	36	typ.	27 dB
Group delay (relative to 0 ns at 32,7 MHz)	32,0 to 38,5	max.	+40 ns
		min.	-40 ns
Spurious reflections and direct breakthrough	32,7	max.	-40 dB
Temperature coefficient of frequency		typ.	-90 × 10 ⁻⁶ /K
Small-signal impedance			
input	36,0		1,9 kΩ / / 6,8 pF
output	36,0		3,1 kΩ / / 10,3 pF

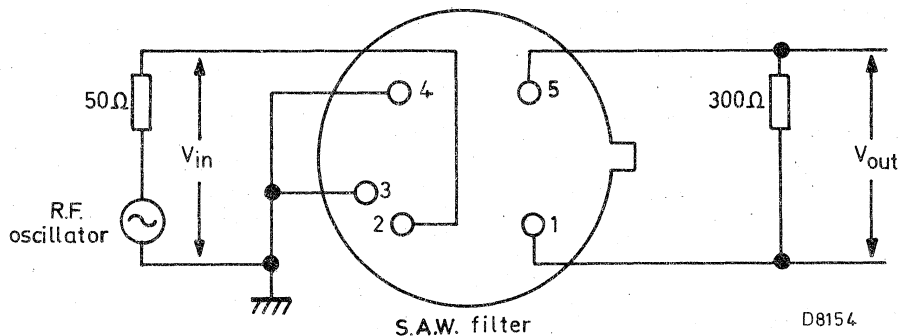

Fig. 2 Test and basic application circuit.

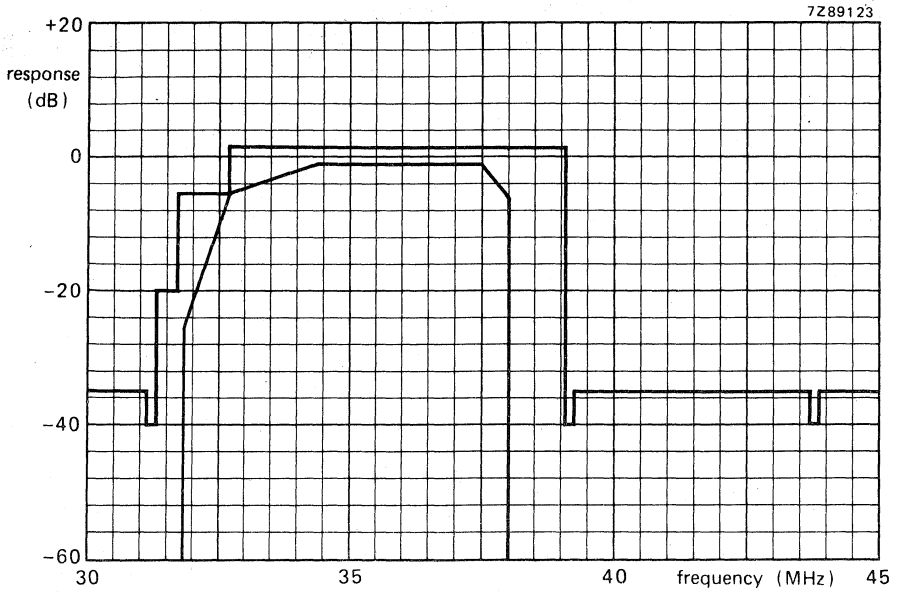

Fig. 3 Tolerance graticule.

Contents

DATA HANDBOOK SYSTEM

TELEVISION TUNERS AND AERIAL INPUT ASSEMBLIES

page

Television tuners

ELC2004	3
ELC2006	19
ELC2060	37
ELC2070	55
ELC3082	69
U323	81
U341, U341LO	93
U342, U342LO	107
U411, U412	121
UF5	133
UV411, UV412	141
UV413, UV414	157
UV415, UV416	173
UVF10	189
V311	203
V317, V317LO	217
V334, V334LO	231
VF5	247

Coaxial aerial input assemblies

3122 127 10260	
3122 127 10450	
3122 127 14730	257
3122 127 21300	263

VIDEO MODULATORS

Video modulators

REMO 101	
REMO 201	3
REMO 301	9

SURFACE ACOUSTIC WAVE FILTERS

Surface acoustic wave filters

RW153A	3
RW154	9
RW171	13
RW173	19
RW300	25

TUNERS



TELEVISION TUNERS AND AERIAL INPUT ASSEMBLIES



VIDEO MODULATORS



SURFACE ACOUSTIC WAVE FILTERS



CONTENTS

Electronic components and materials for professional, industrial and consumer uses from the world-wide Philips Group of Companies

- Argentina:** PHILIPS ARGENTINA S.A., Div. Elcoma, Vedia 3892, 1430 BUENOS AIRES, Tel. 541-7141/7242/7343/7444/7545.
- Australia:** PHILIPS INDUSTRIES HOLDINGS LTD., Elcoma Division, 67 Mars Road, LANE COVE, 2066, N.S.W., Tel. 427 08 88.
- Austria:** ÖSTERREICHISCHE PHILIPS BAUELEMENTE Industrie G.m.b.H., Triester Str. 64, A-1101 WIEN, Tel. 62 91 11.
- Belgium:** N.V. PHILIPS & MBLE ASSOCIATED, 9, rue du Pavillon, B-1030 BRUXELLES, Tel. (02) 242 74 00.
- Brazil:** IBRAPE, Caixa Postal 7383, Av. Brigadeiro Faria Lima, 1735 SAO PAULO, SP, Tel. (011) 211-2600.
- Canada:** PHILIPS ELECTRONICS LTD., Electron Devices Div., 601 Milner Ave., SCARBOROUGH, Ontario, M1B 1M8, Tel. 292-5161.
- Chile:** PHILIPS CHILENA S.A., Av. Santa Maria 0760, SANTIAGO, Tel. 39-4001.
- Colombia:** SADAPE S.A., P.O. Box 9805, Calle 13, No. 51 + 39, BOGOTA D.E. 1., Tel. 600 600.
- Denmark:** MINIWATT A/S, Emdrupvej 115A, DK-2400 KØBENHAVN NV., Tel. (01) 69 16 22.
- Finland:** OY PHILIPS AB, Elcoma Division, Kaivokatu 8, SF-00100 HELSINKI 10, Tel. 1 72 71.
- France:** R.T.C. LA RADIOTECHNIQUE-COMPELEC, 130 Avenue Ledru Rollin, F-75540 PARIS 11, Tel. 355-44-99.
- Germany:** VALVO, UB Bauelemente der Philips G.m.b.H., Valvo Haus, Burchardstrasse 19, D-2 HAMBURG 1, Tel. (040) 3296-0.
- Greece:** PHILIPS S.A. HELLENIQUE, Elcoma Division, 52, Av. Syngrou, ATHENS, Tel. 9215111.
- Hong Kong:** PHILIPS HONG KONG LTD., Elcoma Div., 15/F Philips Ind. Bldg., 24-28 Kung Yip St., KWAI CHUNG, Tel. (0)-24 51 21.
- India:** PEICO ELECTRONICS & ELECTRICALS LTD., Elcoma Div., Ramon House, 169 Backbay Reclamation, BOMBAY 400020, Tel. 295144.
- Indonesia:** P.T. PHILIPS-RALIN ELECTRONICS, Elcoma Div., Panim Bank Building, 2nd Fl., Jl. Jend. Sudirman, P.O. Box 223, JAKARTA, Tel. 716 131.
- Ireland:** PHILIPS ELECTRICAL (IRELAND) LTD., Newstead, Clonskeagh, DUBLIN 14, Tel. 69 33 55.
- Italy:** PHILIPS S.p.A., Sezione Elcoma, Piazza IV Novembre 3, I-20124 MILANO, Tel. 2-6994.
- Japan:** NIHON PHILIPS CORP., Shuwa Shinagawa Bldg., 26-33 Takanawa 3-chome, Minato-ku, TOKYO (108), Tel. 448-5611.
(IC Products) SIGNETICS JAPAN LTD., 8-7 Sanbancho Chiyoda-ku, TOKYO 102, Tel. (03)230-1521.
- Korea:** PHILIPS ELECTRONICS (KOREA) LTD., Elcoma Div., Philips House, 260-199 Itaewon-dong, Yongsan-ku, C.P.O. Box 3680, SEOUL, Tel. 794-4202.
- Malaysia:** PHILIPS MALAYSIA SDN. BERHAD, No. 4 Persiaran Barat, Petaling Jaya, P.O.B. 2163, KUALA LUMPUR, Selangor, Tel. 77 44 11.
- Mexico:** ELECTRONICA S.A. de C.V., Varsovia No. 36, MEXICO 6, D.F., Tel. 533-11-80.
- Netherlands:** PHILIPS NEDERLAND, Marktgroep Elconco, Postbus 90050, 5600 PB EINDHOVEN, Tel. (040) 79 33 33.
- New Zealand:** PHILIPS ELECTRICAL LTD., Elcoma Division, 2 Wagener Place, St. Lukes, AUCKLAND, Tel. 894-160.
- Norway:** NORSK A/S PHILIPS, Electronica Dept., Sandstuveien 70, OSLO 6, Tel. 68 02 00.
- Peru:** CADESA, Av. Alfonso Ugarte 1268, LIMA 5, Tel. 326070.
- Philippines:** PHILIPS INDUSTRIAL DEV. INC., 2246 Pasong Tamo, P.O. Box 911, Makati Comm. Centre, MAKATI-RIZAL 3116, Tel. 86-89-51 to 59.
- Portugal:** PHILIPS PORTUGUESA S.A.R.L., Av. Eng. Duarte Pacheco 6, LISBOA 1, Tel. 68 31 21.
- Singapore:** PHILIPS PROJECT DEV. (Singapore) PTE LTD., Elcoma Div., Lorong 1, Toa Payoh, SINGAPORE 1231, Tel. 25 38 811.
- South Africa:** EDAC (Pty.) Ltd., 3rd Floor Rainer House, Upper Railway Rd. & Ove St., New Doornfontein, JOHANNESBURG 2001, Tel. 614-2362-9.
- Spain:** MINIWATT S.A., Balmes 22, BARCELONA 7, Tel. 3016312.
- Sweden:** PHILIPS KOMPLEMENTER A.B., Lidingsvägen 50, S-11584 STOCKHOLM 27, Tel. 08/67 97 80.
- Switzerland:** PHILIPS A.G., Elcoma Dept., Allmendstrasse 140-142, CH-8027 ZÜRICH, Tel. 01 488 22 11.
- Taiwan:** PHILIPS TAIWAN LTD., 3rd Fl., San Min Building, 57-1, Chung Shan N. Rd, Section 2, P.O. Box 22978, TAIPEI, Tel. (02)-5631717.
- Thailand:** PHILIPS ELECTRICAL CO. OF THAILAND LTD., 283 Silom Road, P.O. Box 961, BANGKOK, Tel. 233-6330-9.
- Turkey:** TÜRK PHILIPS TICARET A.S., EMET Department, Inonu Cad. No. 78-80, ISTANBUL, Tel. 43 59 10.
- United Kingdom:** MULLARD LTD., Mullard House, Torrington Place, LONDON WC1E 7HD, Tel. 01-580 6633.
- United States:** (Active Devices & Materials) AMPEREX SALES CORP., Providence Pike, SLATERSVILLE, R.I. 02876, Tel. (401) 762-9000.
(Passive Devices) MEPCO/ELECTRA INC., Columbia Rd., MORRISTOWN, N.J. 07960, Tel. (201) 539-2000.
(Passive Devices & Electromechanical Devices) CENTRALAB INC., 5855 N. Glen Park Rd., MILWAUKEE, WI 53201, Tel. (414) 228-7380.
(IC Products) SIGNETICS CORPORATION, 811 East Arques Avenue, SUNNYVALE, California 94086, Tel. (408) 739-7700.
- Uruguay:** LUZILECTRON S.A., Avda Uruguay 1287, P.O. Box 907, MONTEVIDEO, Tel. 91 43 21.
- Venezuela:** IND. VENEZOLANAS PHILIPS S.A., Elcoma Dept., A. Ppal de los Ruices, Edif. Centro Colgate, CARACAS, Tel. 36 05 11.
- For all other countries apply to:** Philips Electronic Components and Materials Division, Corporate Relations & Projects, Building BAE3, 5600 MD EINDHOVEN, THE NETHERLANDS, Tel. (040) 72 33 04, Telex 35000.

A30

© 1982 Philips Export B.V.

This information is furnished for guidance, and with no guarantees as to its accuracy or completeness; its publication conveys no licence under any patent or other right, nor does the publisher assume liability for any consequence of its use; specifications and availability of goods mentioned in it are subject to change without notice; it is not to be reproduced in any way, in whole or in part, without the written consent of the publisher.